

MR EAVES SANS & MODERN

Designed by Zuzana Licko in 2009.

Mr Eaves is the sans-serif companion to Mrs Eaves <<https://www.emigre.com/Fonts/Mrs-Eaves>>, one of Emigre’s classic typeface designs. Created by Zuzana Licko, this addition to the Emigre Type Library expands the versatility of the original Mrs Eaves with two complementary families: Mr Eaves Sans and Mr Eaves Modern.

Mr Eaves was based on the proportions of Mrs Eaves, but Licko took some liberty with its design. One of the main concerns was to avoid creating a typeface that looked like it simply had its serifs cut off. And while it matches Mrs Eaves in weight, color, and armature, Mr Eaves stands as its own typeface with many unique characteristics.

The Sans version relates most directly to the original serif version, noticeably in the roman lower case letters a, e, and g, as well as in subtle details such as the angled lead-in strokes, the counter forms of the b, d, p, and q, and the flared leg of the capital R, the tail of the Q.

The distinctly loose-fitting letter spacing of Mrs Eaves was applied also to the Sans version. This, together with generous built-in line spacing due to a small x-height and extended ascenders and descenders, renders the same kind of lightness and airiness when setting text that is so characteristic of Mrs Eaves.

Deviations from the original Mrs Eaves are evident in the overall decrease of contrast, as well as in details such as the flag and tail of the f and j, and the finial of the t, which were shortened to maintain a cleaner, sans serif look. And the lower case c had to be balanced out differently after it lost its top ball terminal. And with the loss of serifs, Mr Eaves set width is slightly narrower.

Mr Eaves Italic also carries over many forms from its Mrs Eaves model, most notably the v, w, and z, which are unusually flamboyant for a sans

italic design. It also utilizes lead-in and terminal tails that are reminiscent of the serif italic. The biggest departure here is the width of the characters. The extra narrow gauge and delicate features seemed more appropriate for the Serif than the Sans. To allow for a comfortable fit, Mr Eaves Italic has a more robust design and wider character width.

Meanwhile, the Modern family provides an overall less humanistic look, with simpler and more geometric-looking shapes, most noticeably in the squared-off terminals and symmetric lower case counters. This family has moved furthest from its roots, yet still contains some of Mrs Eaves’ DNA. The Modern Italic is free of tails, and overall the Modern exhibits more repetition of forms, projecting a cleaner look. This provides stronger differentiation from the serif version whenever a more contrasting look is desired.

Each version (Sans and Modern) contains its own set of alternates providing unique options for applications such as headlines, word logos, letterheads, pull quotes, and other short text settings.

Both the Sans and Modern come in three weights. Regular and Bold match the original Mrs Eaves weights, while the Heavy provides an additional weight for extra emphasis.

For more information, see:
<<https://www.emigre.com/Fonts/Mr-Eaves-Sans-and-Modern>>

More Digital Font Sketches:
<<https://www.emigre.com/DigitalFontSketches>>

MR EAVES SANS & MODERN

MrEavesSan T | eth | RoboFog Sketches | 2009 | Emigre Fonts

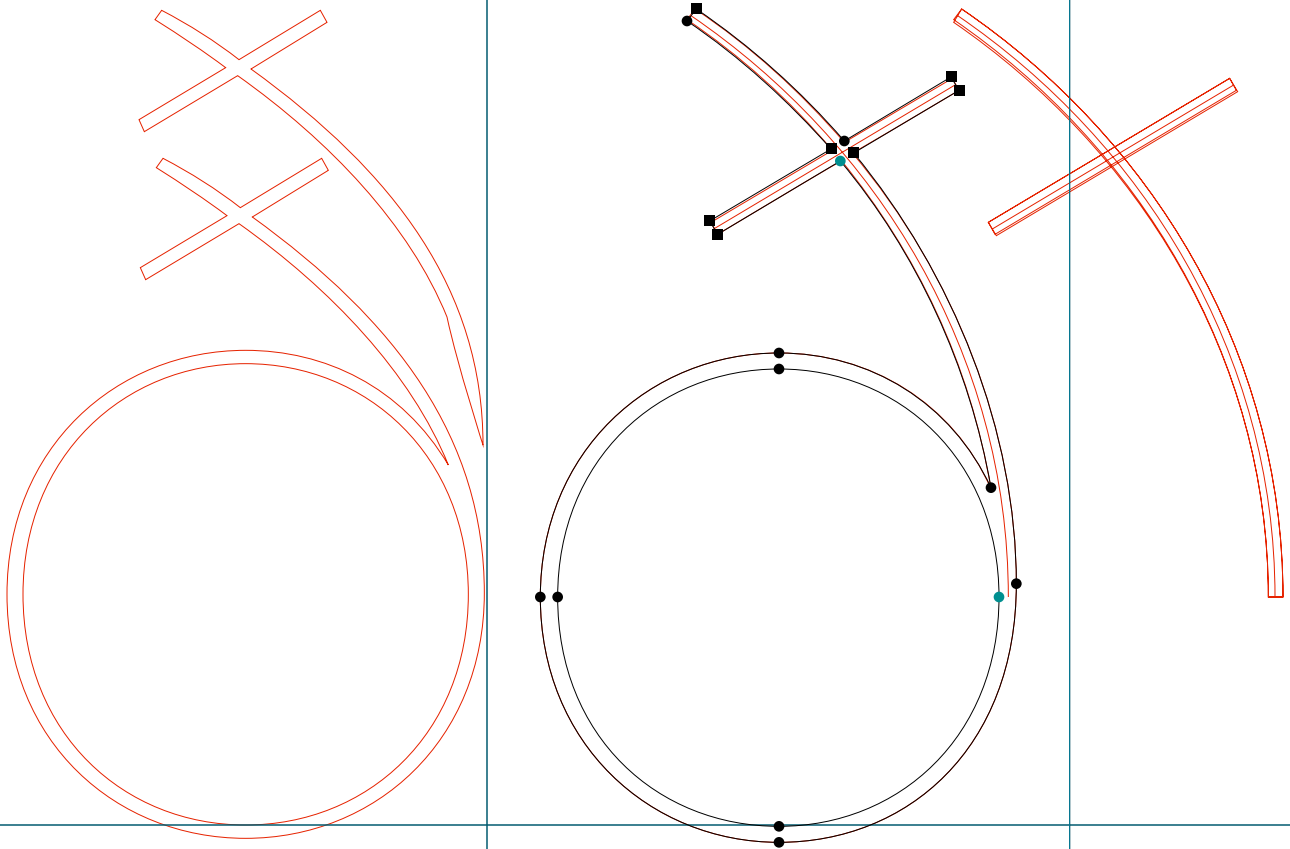

MR EAVES SANS & MODERN

MrEavesSan T | DC2 | RoboFog Sketches | 2009 | Emigre Fonts

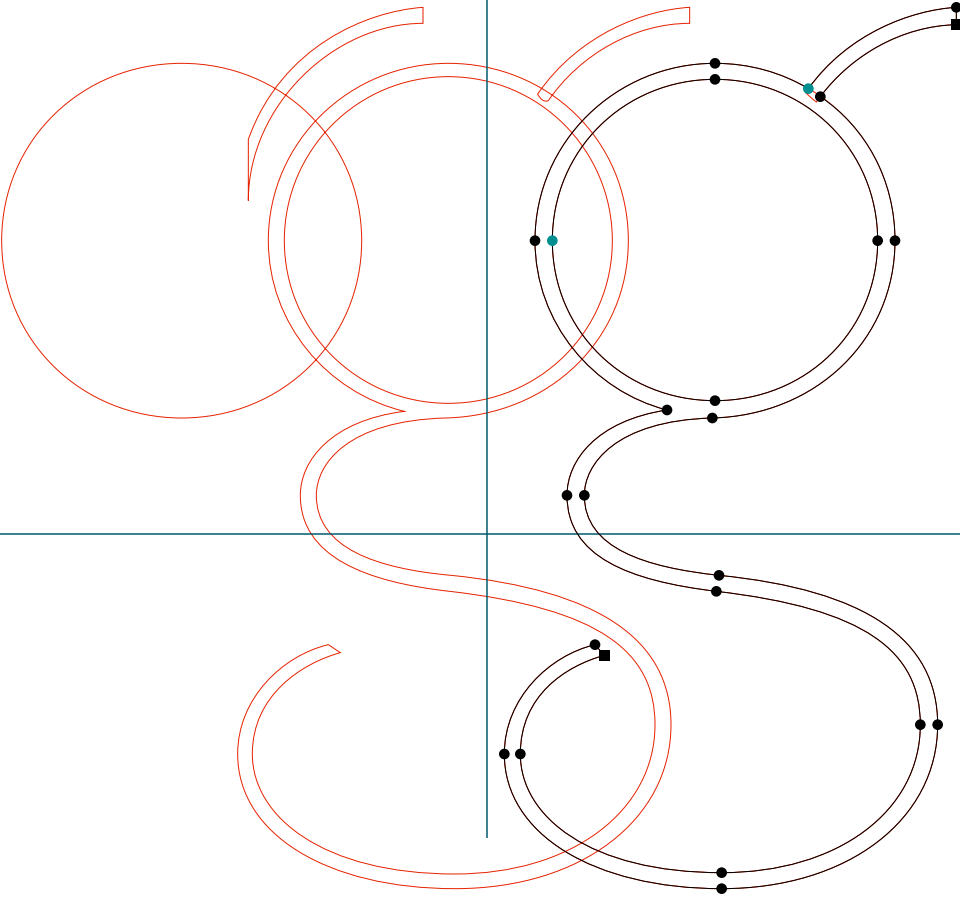

MR EAVES SANS & MODERN

MrEavesSan T | comma | RoboFog Sketches | 2009 | Emigre Fonts

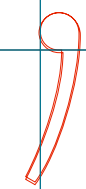
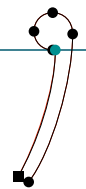

MR EAVES SANS & MODERN

MrEavesSan T | at | RoboFog Sketches | 2009 | Emigre Fonts

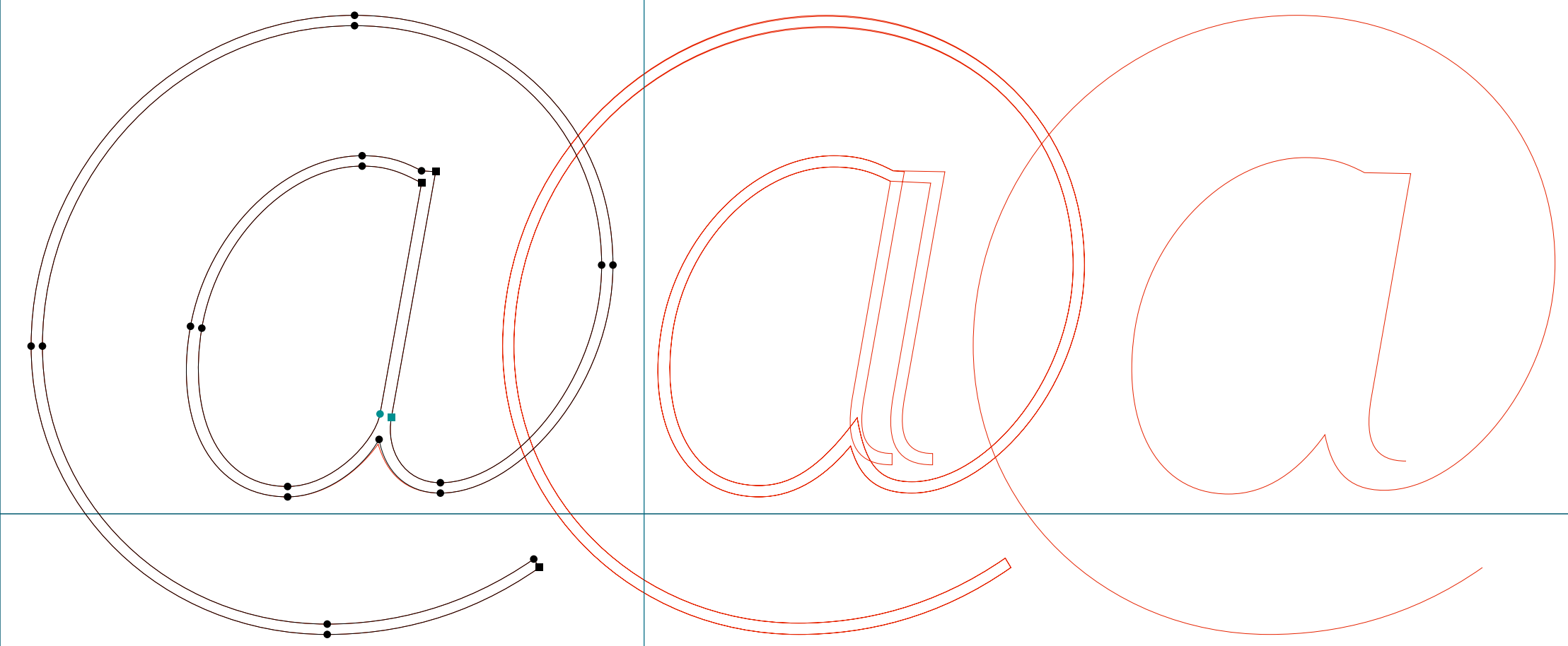

MR EAVES SANS & MODERN

MrEavesSan T | B | RoboFog Sketches | 2009 | Emigre Fonts

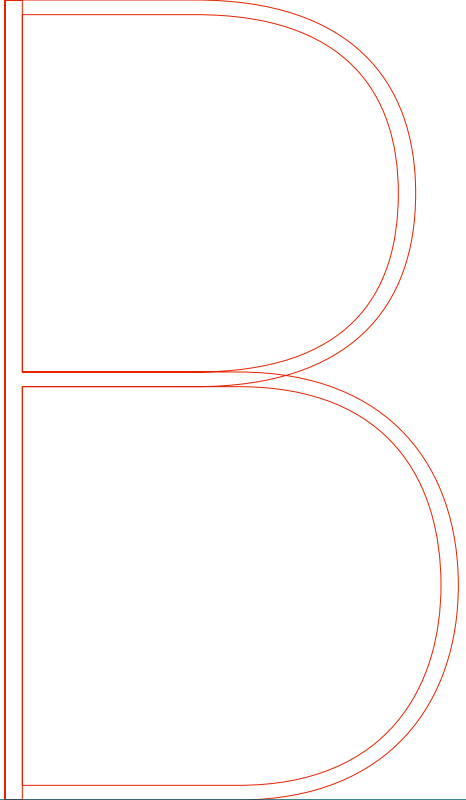
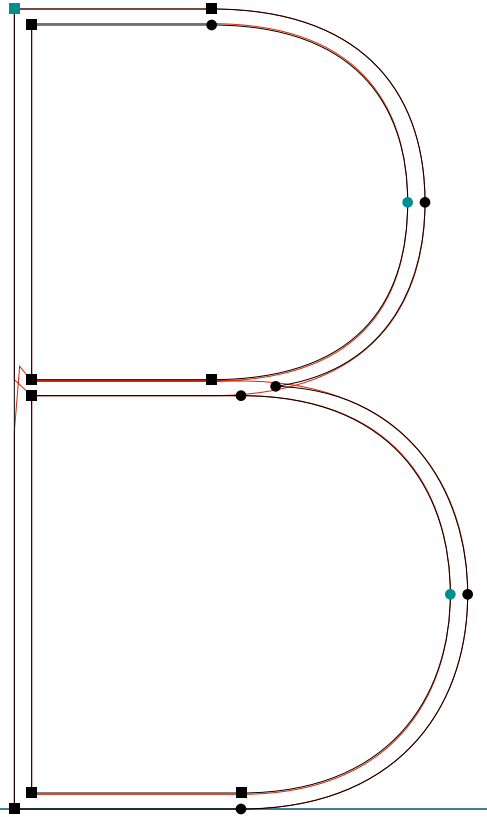
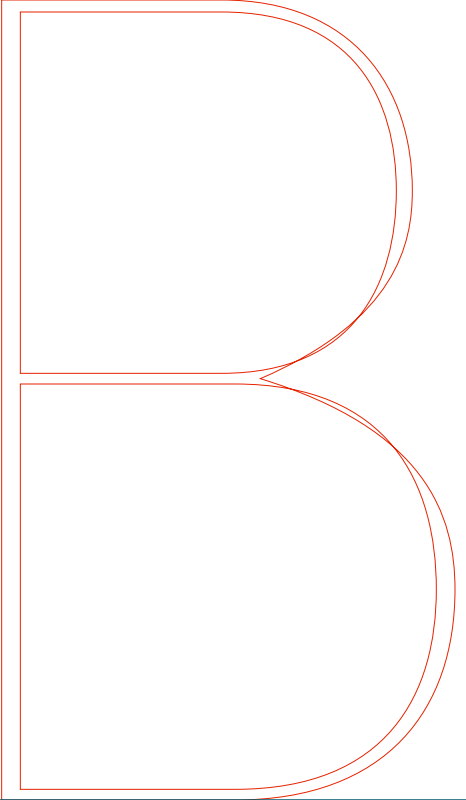

MR EAVES SANS & MODERN

MrEavesSan T | G | RoboFog Sketches | 2009 | Emigre Fonts

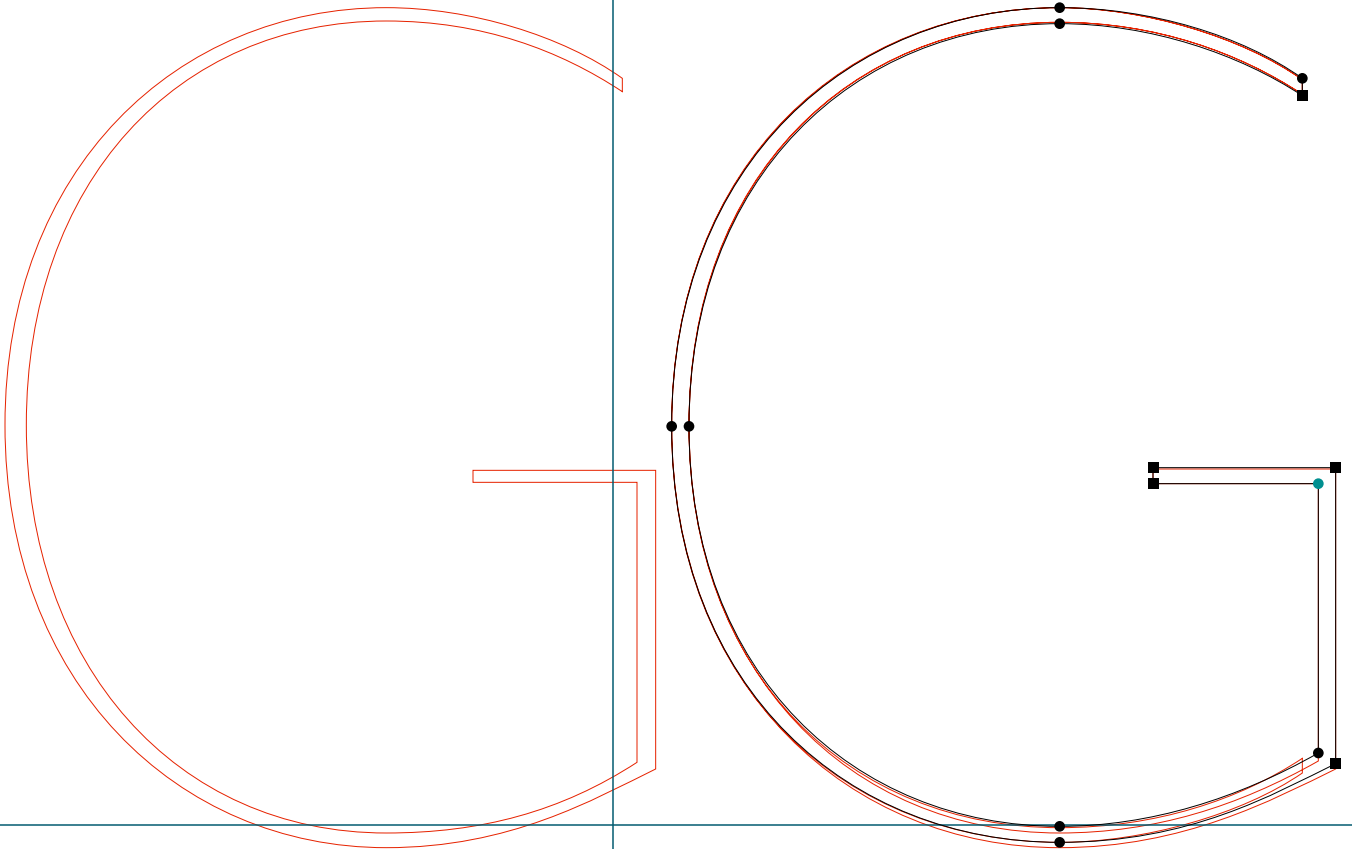

MR EAVES SANS & MODERN

MrEavesSan T | Q | RoboFog Sketches | 2009 | Emigre Fonts

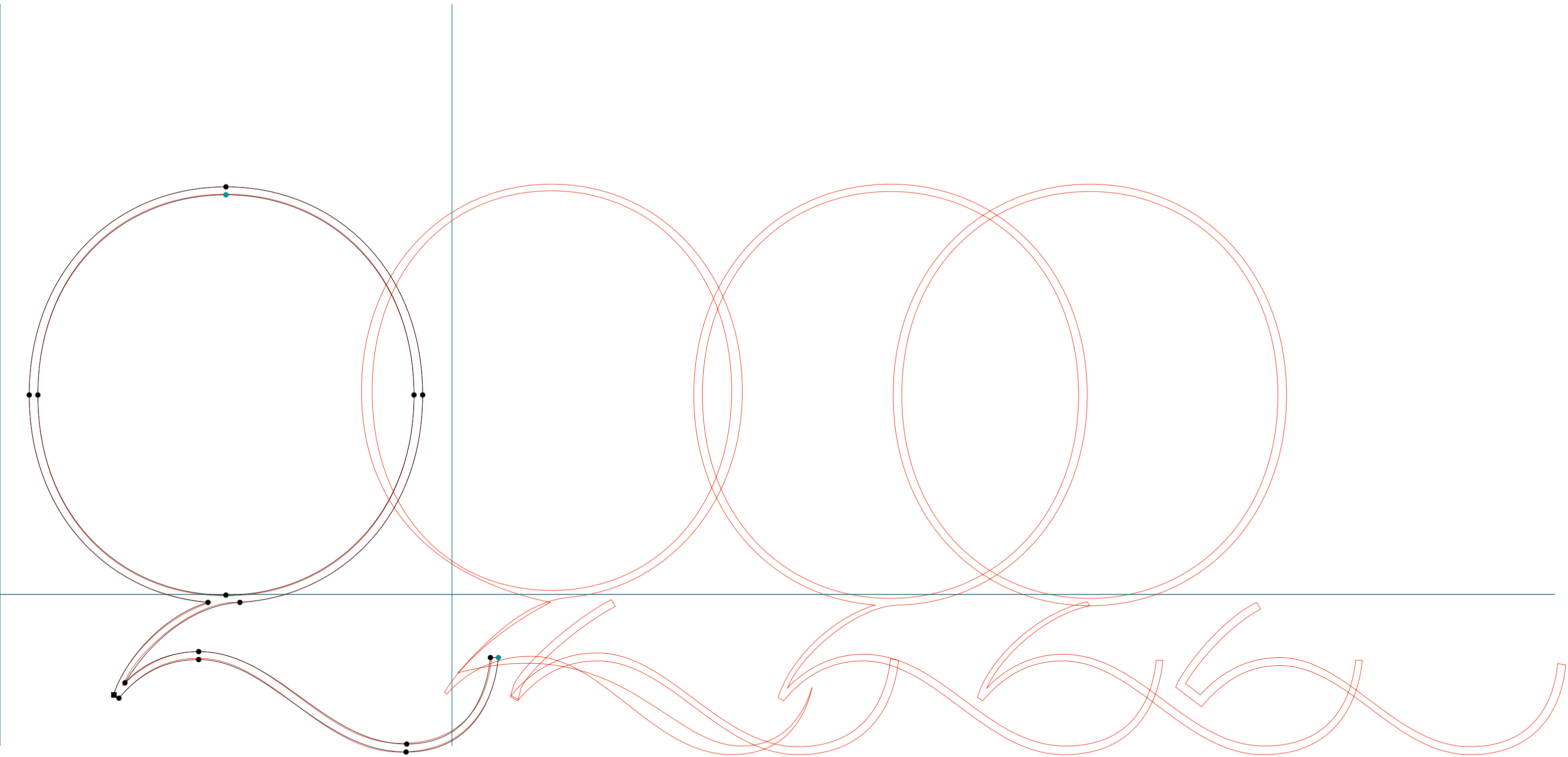

MR EAVES SANS & MODERN

MrEavesSan T | R | RoboFog Sketches | 2009 | Emigre Fonts

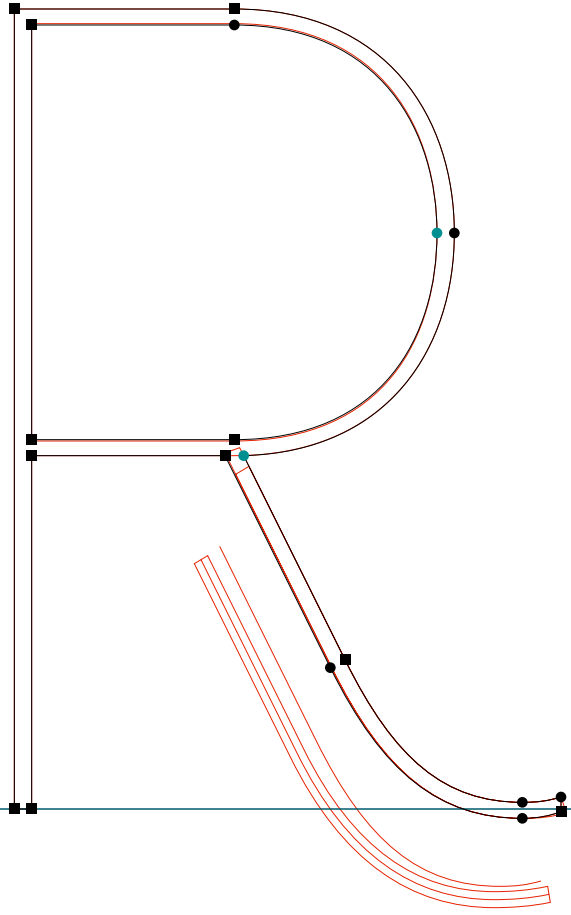
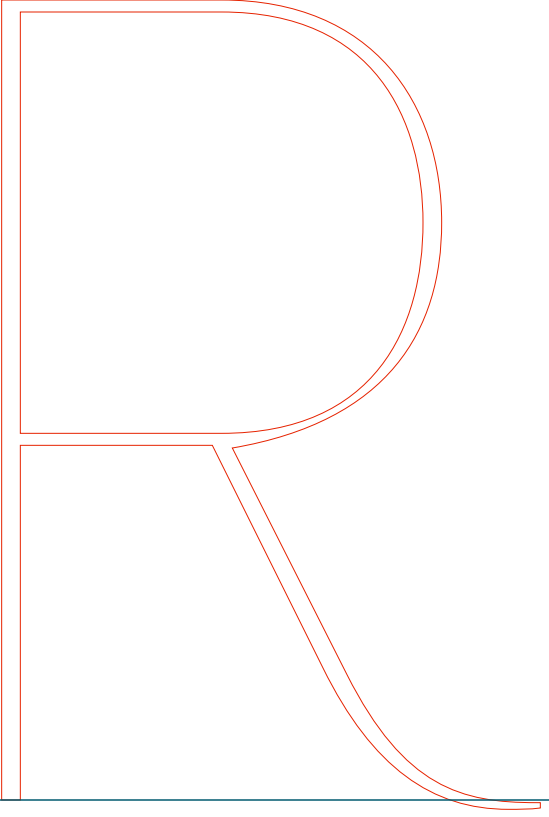

MR EAVES SANS & MODERN

MrEavesSan T | X | RoboFog Sketches | 2009 | Emigre Fonts

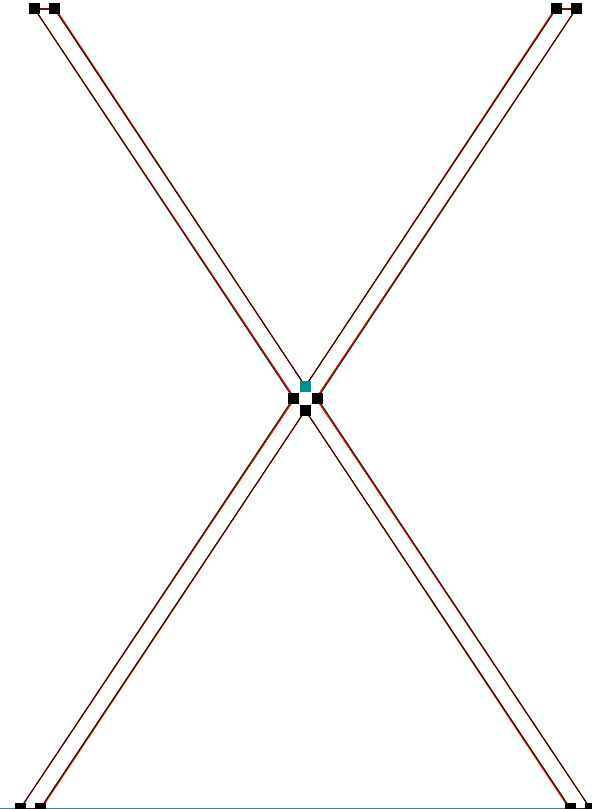
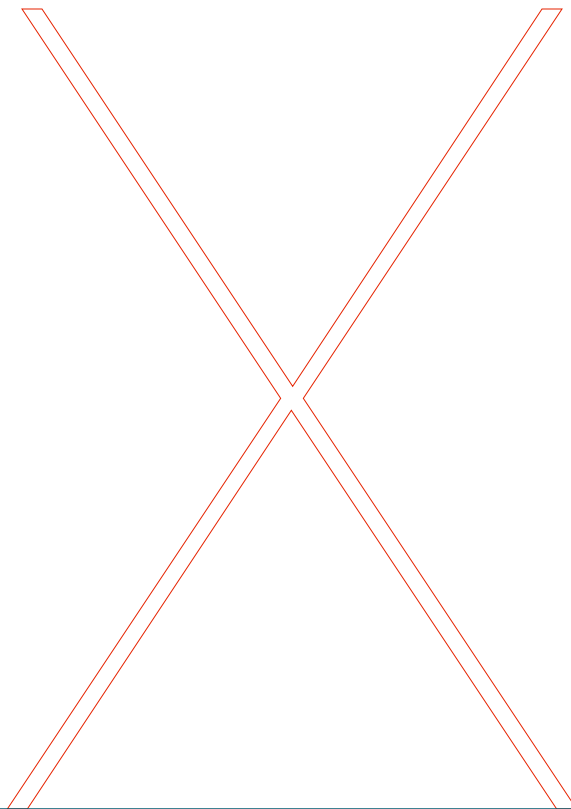

MR EAVES SANS & MODERN

MrEavesSan T | g | RoboFog Sketches | 2009 | Emigre Fonts

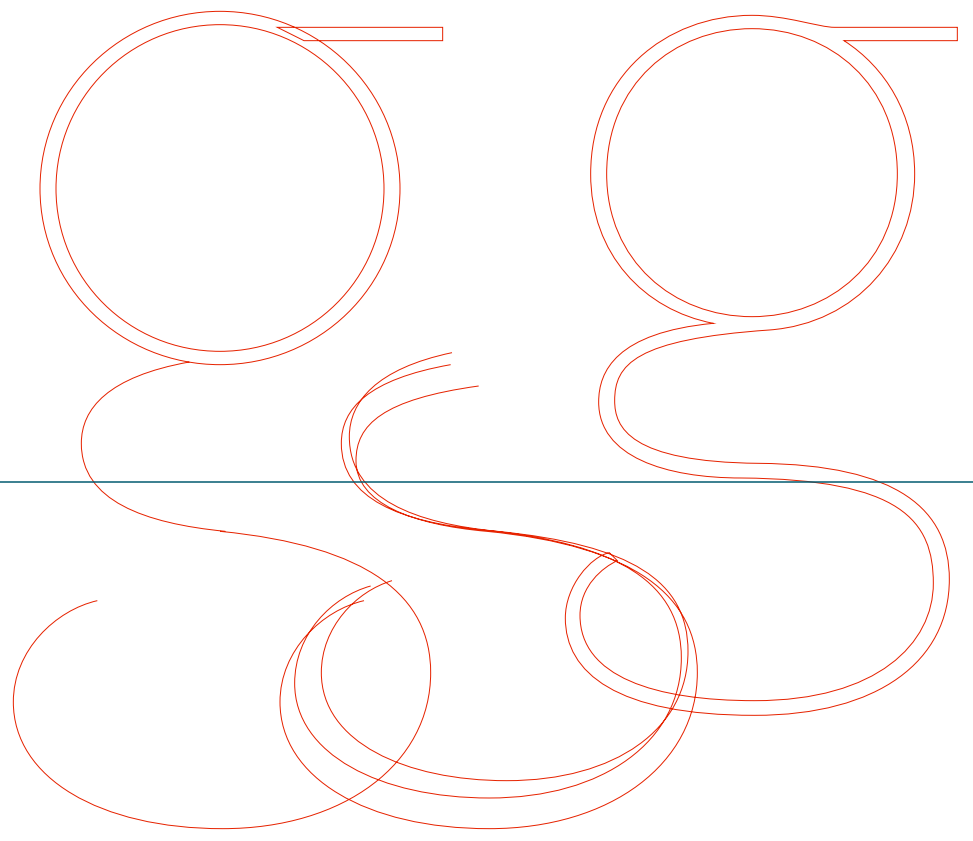
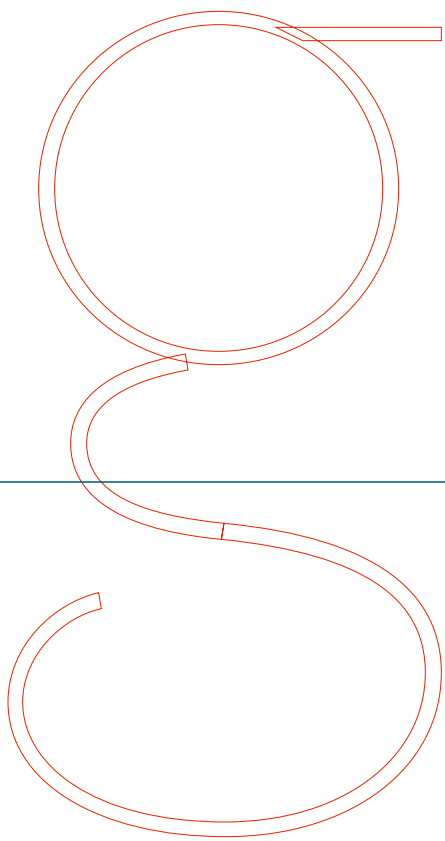
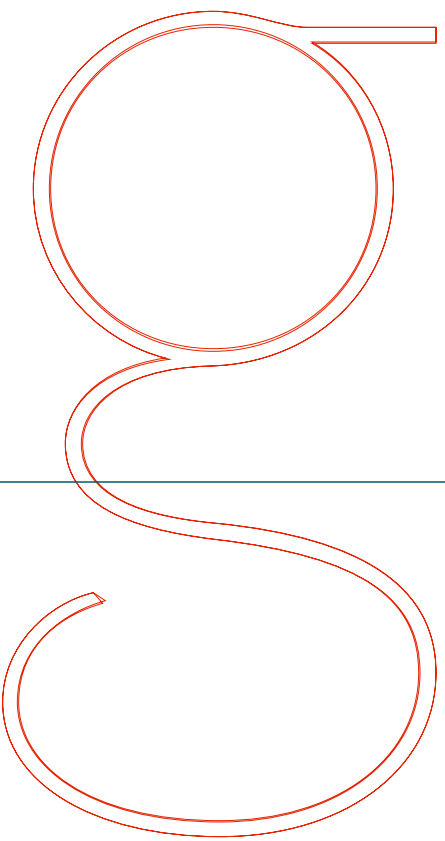
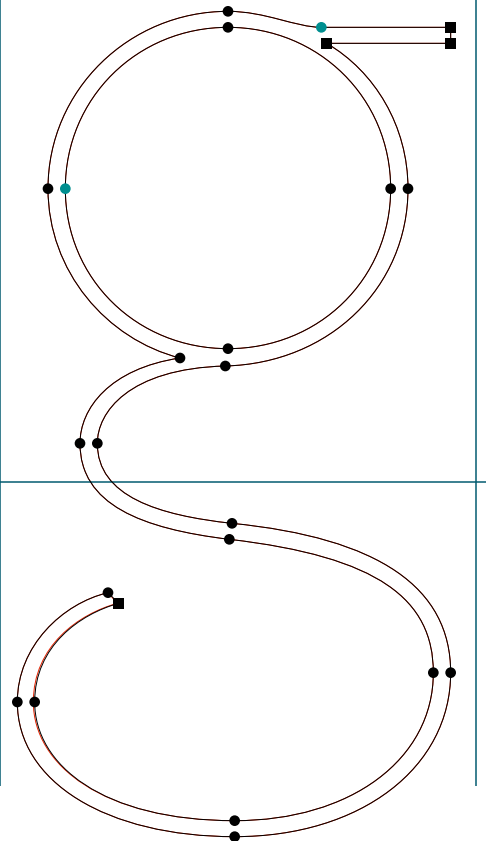
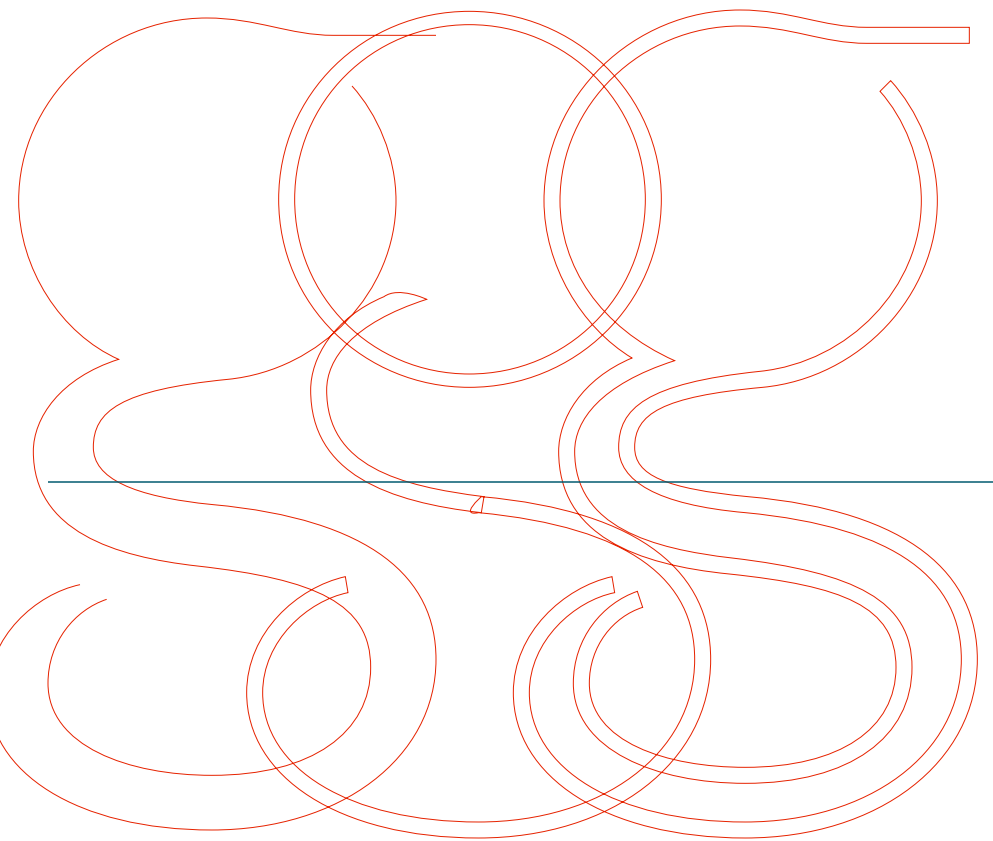

MR EAVES SANS & MODERN

MrEavesSan T | infinity | RoboFog Sketches | 2009 | Emigre Fonts

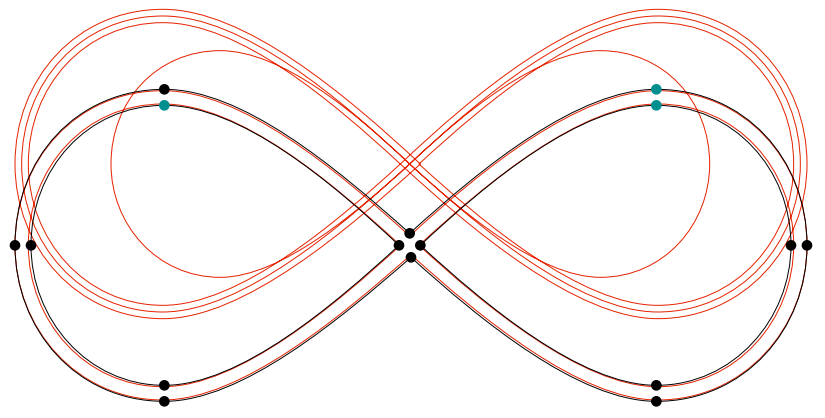

MR EAVES SANS & MODERN

MrEavesSan T | apple | RoboFog Sketches | 2009 | Emigre Fonts

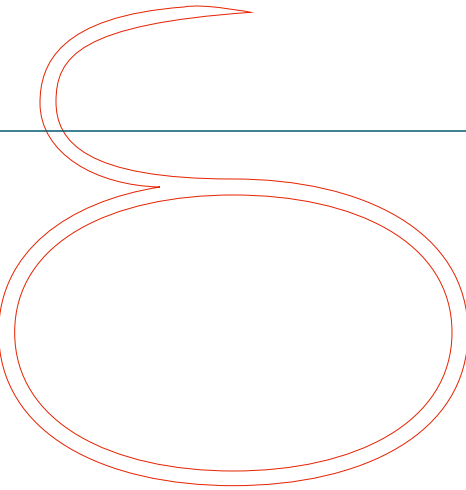
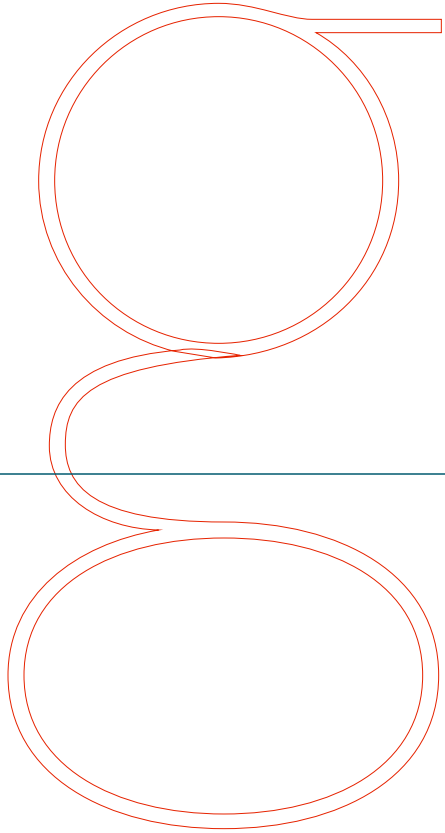
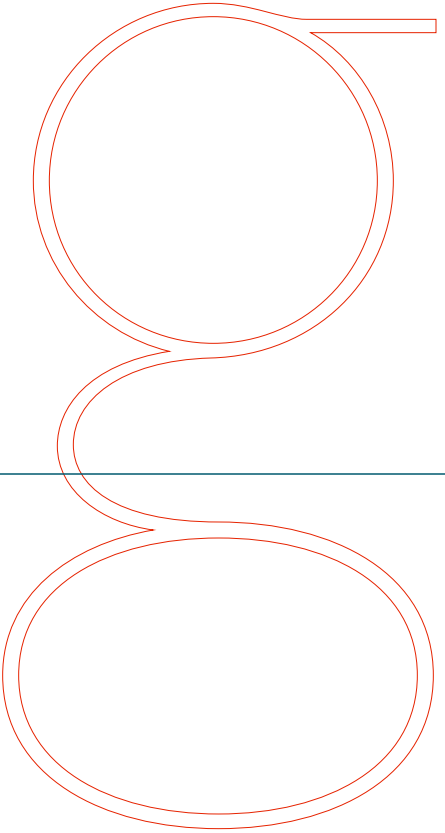
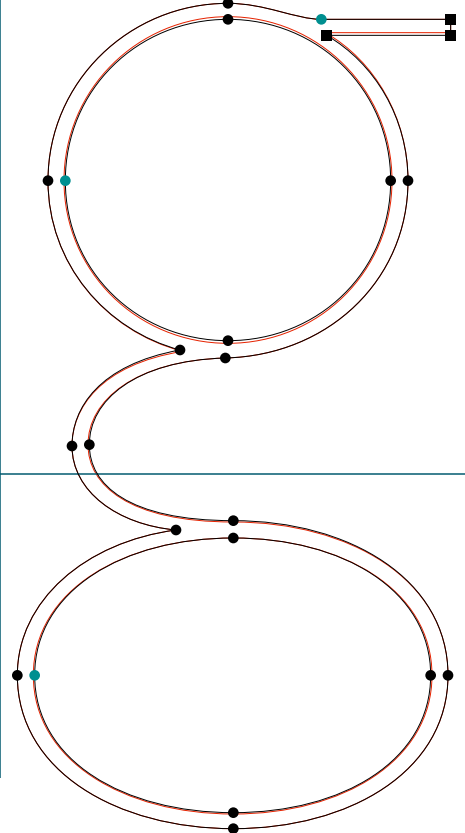
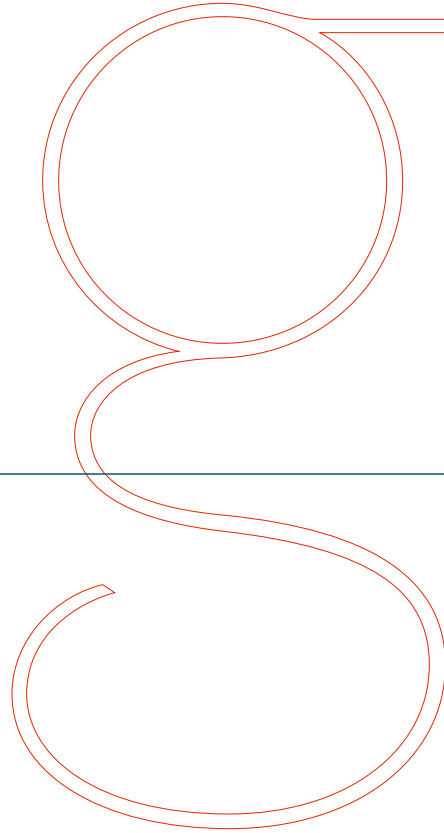

MR EAVES SANS & MODERN

MrEavesSanAlt T | at | RoboFog Sketches | 2009 | Emigre Fonts

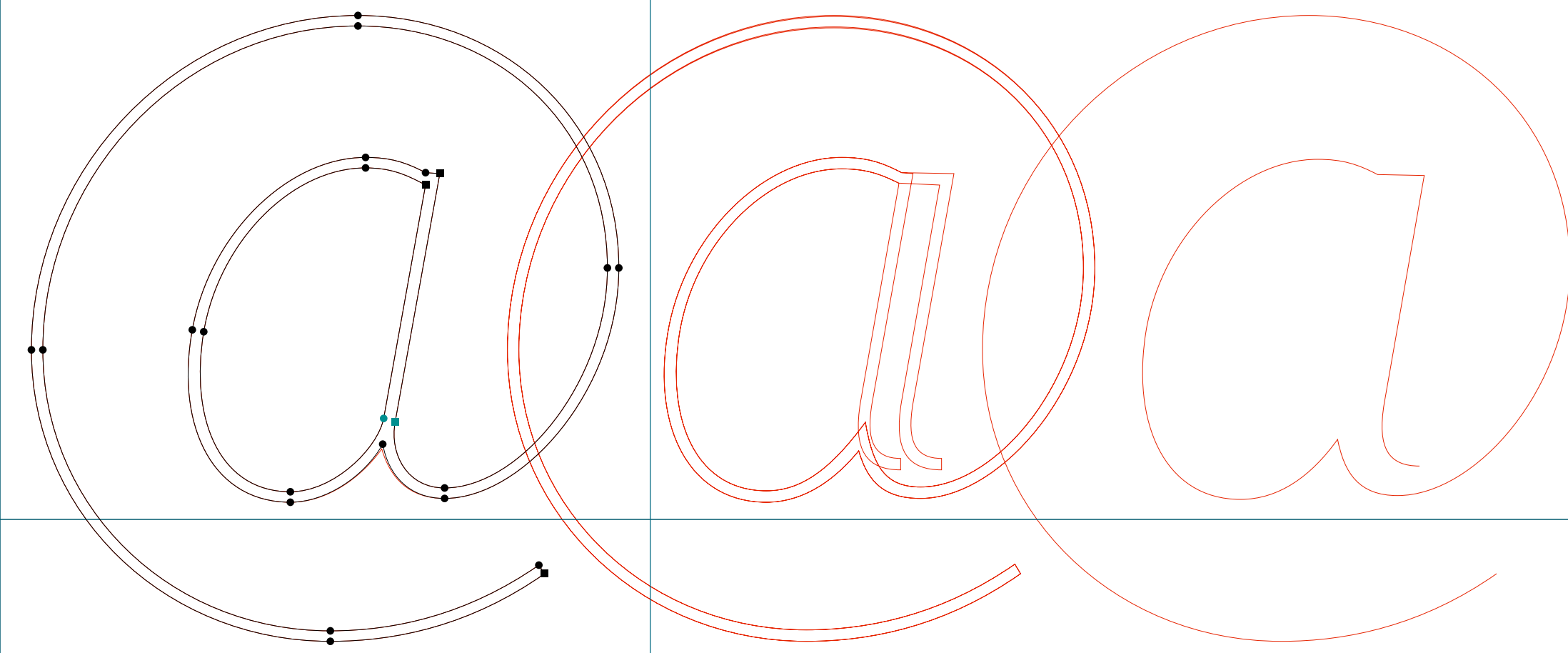

MR EAVES SANS & MODERN

MrEavesSanAlt T | braceleft | RoboFog Sketches | 2009 | Emigre Fonts

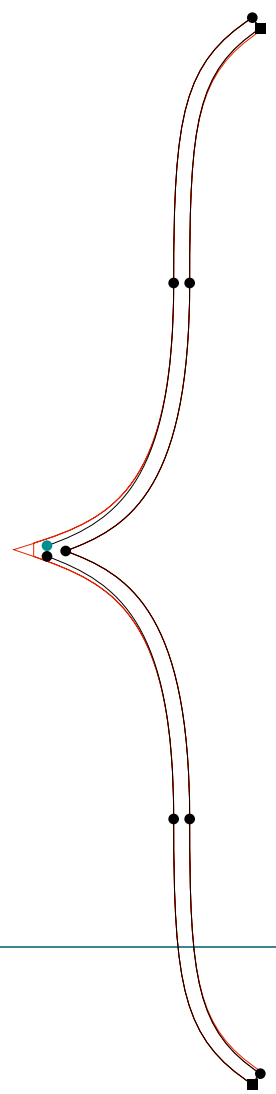
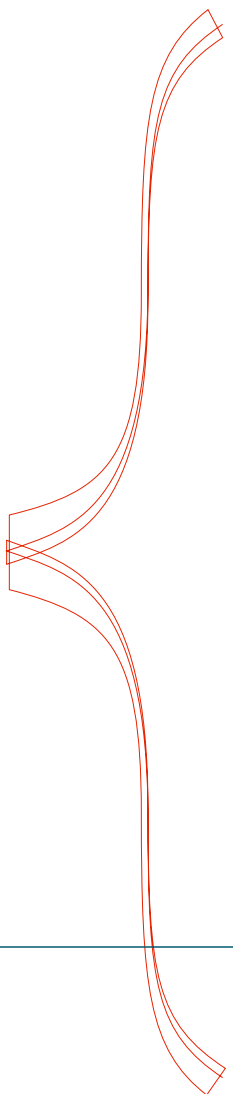

MR EAVES SANS & MODERN

MrEavesSan TI | eth | RoboFog Sketches | 2009 | Emigre Fonts

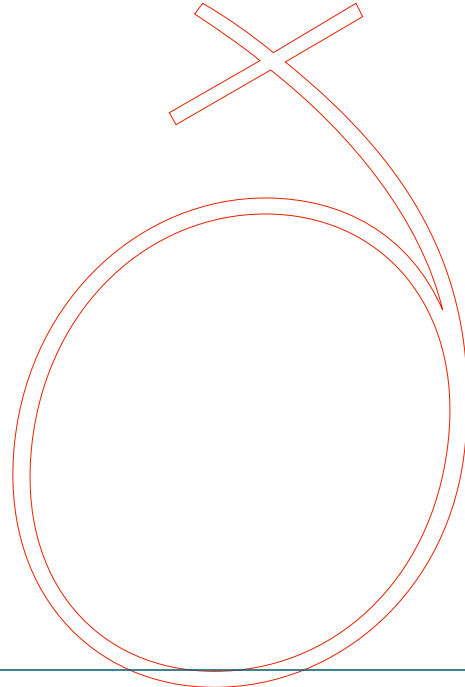
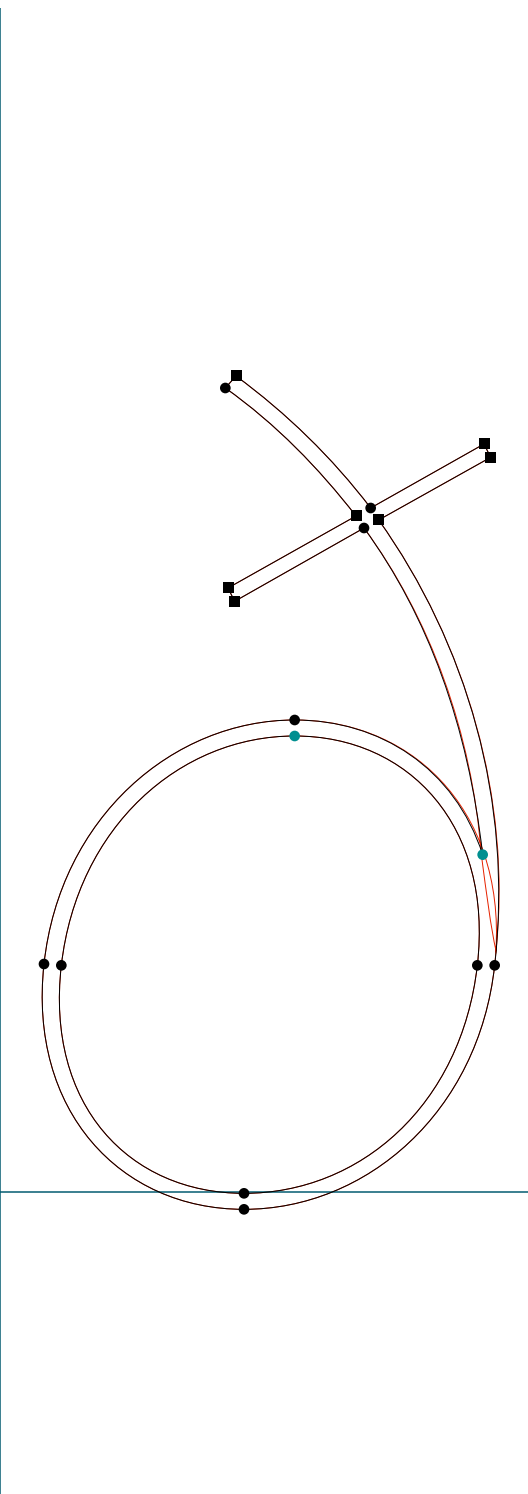

MR EAVES SANS & MODERN

MrEavesSan TI | grave | RoboFog Sketches | 2009 | Emigre Fonts

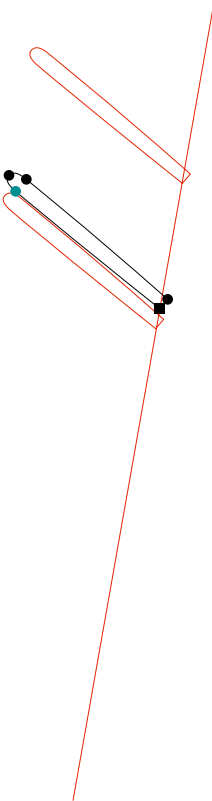

MR EAVES SANS & MODERN

MrEavesSan TI | b | RoboFog Sketches | 2009 | Emigre Fonts

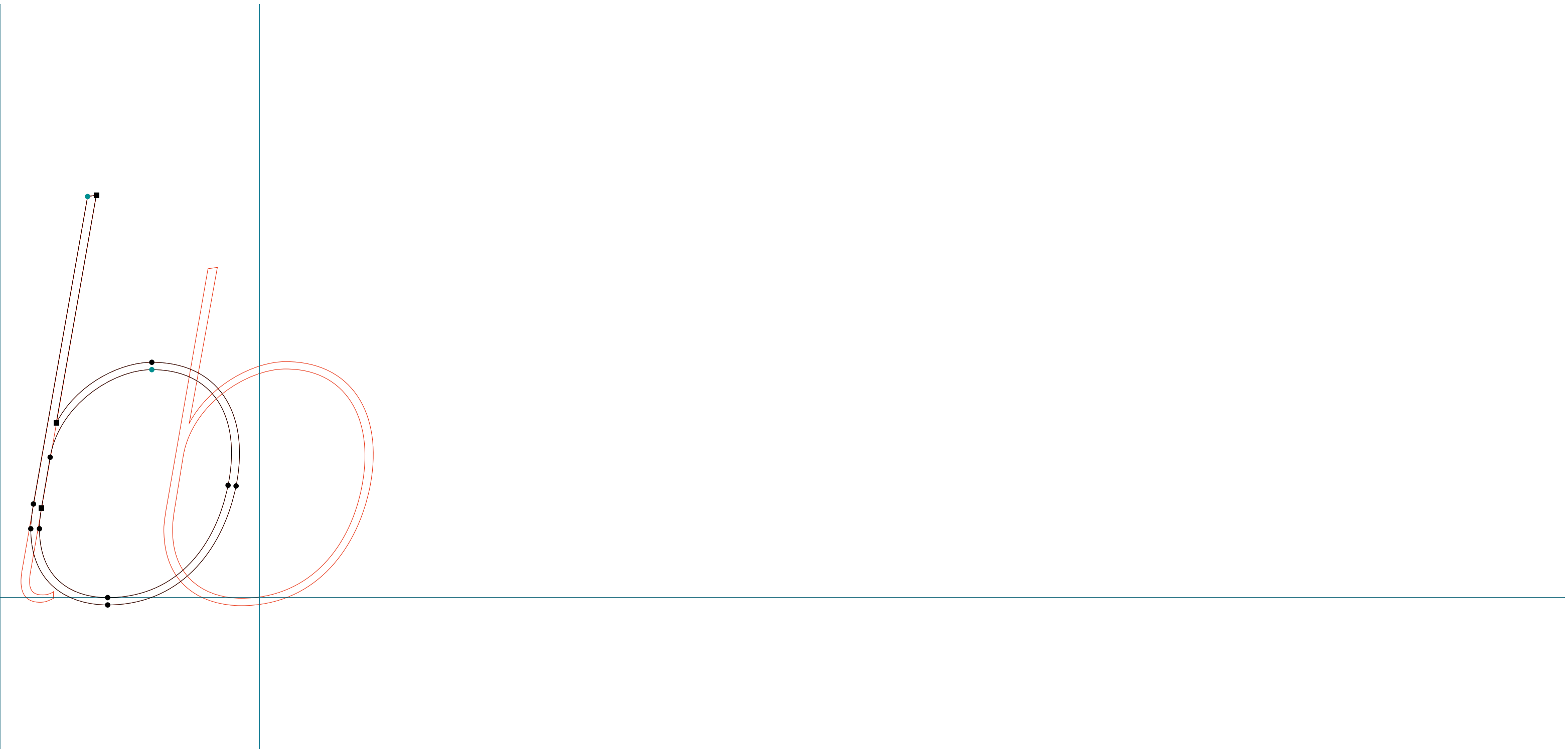

MR EAVES SANS & MODERN

MrEavesSan TI | d | RoboFog Sketches | 2009 | Emigre Fonts

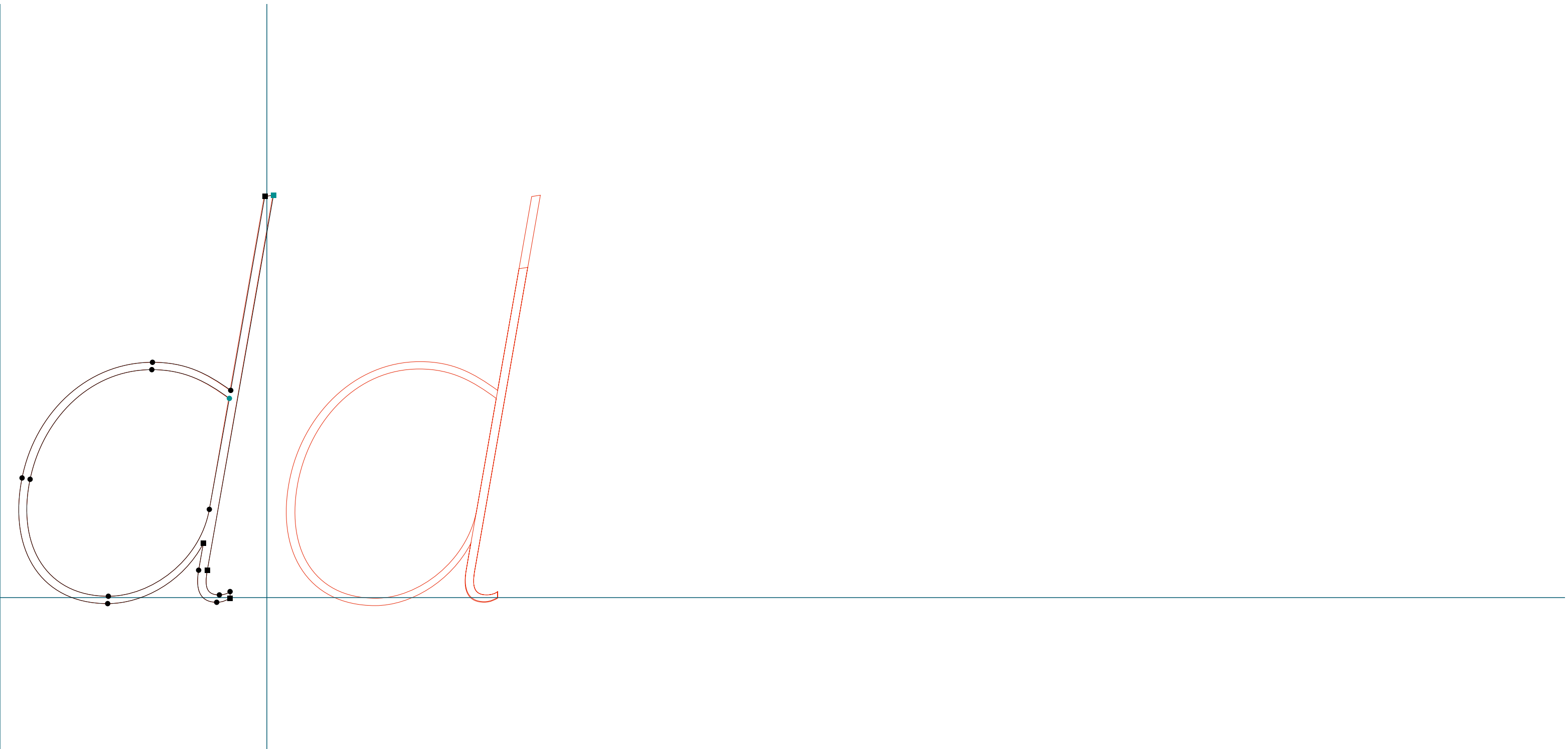

MR EAVES SANS & MODERN

MrEavesSan TI | f | RoboFog Sketches | 2009 | Emigre Fonts

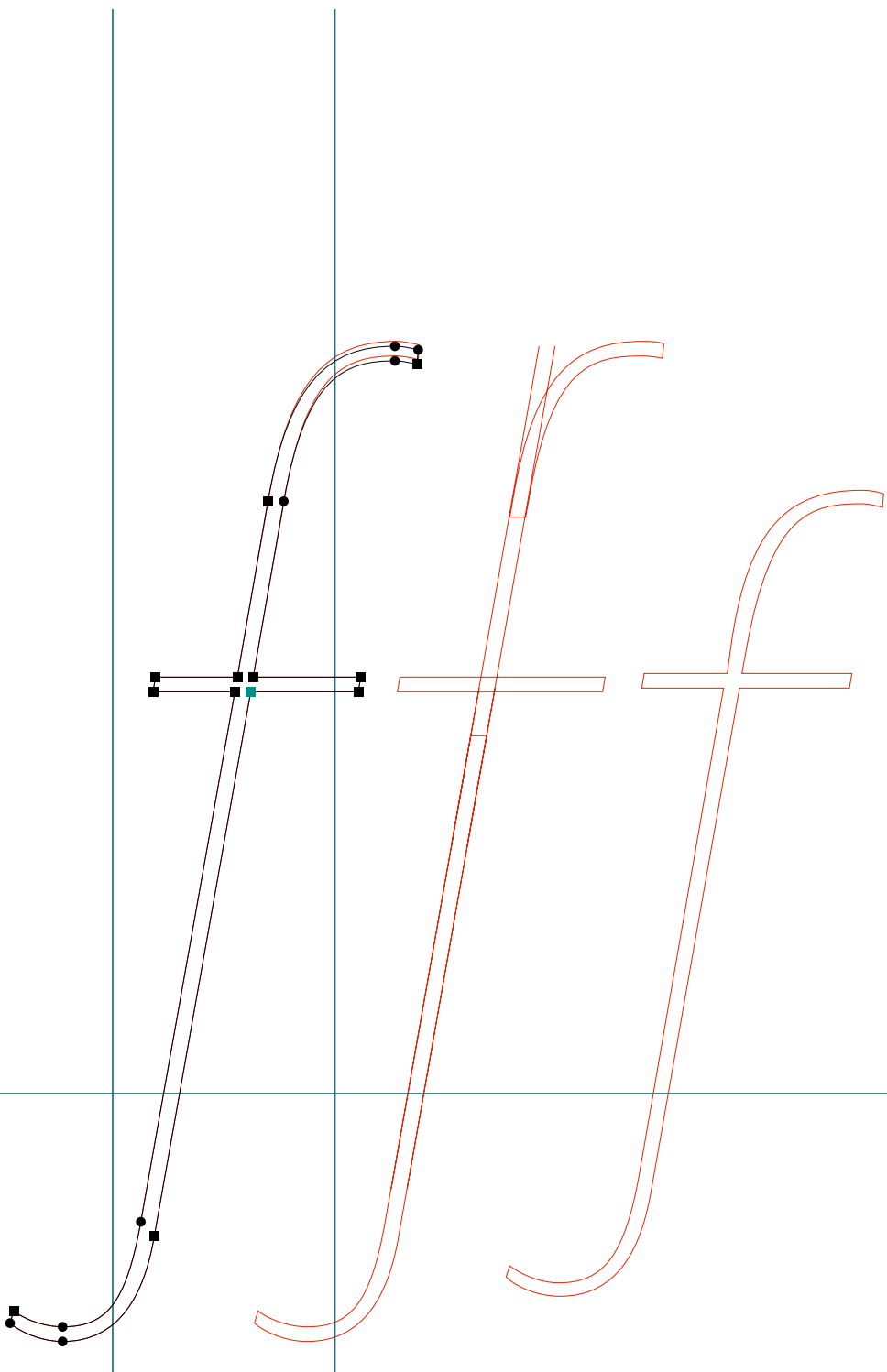

MR EAVES SANS & MODERN

MrEavesSan TI | h | RoboFog Sketches | 2009 | Emigre Fonts

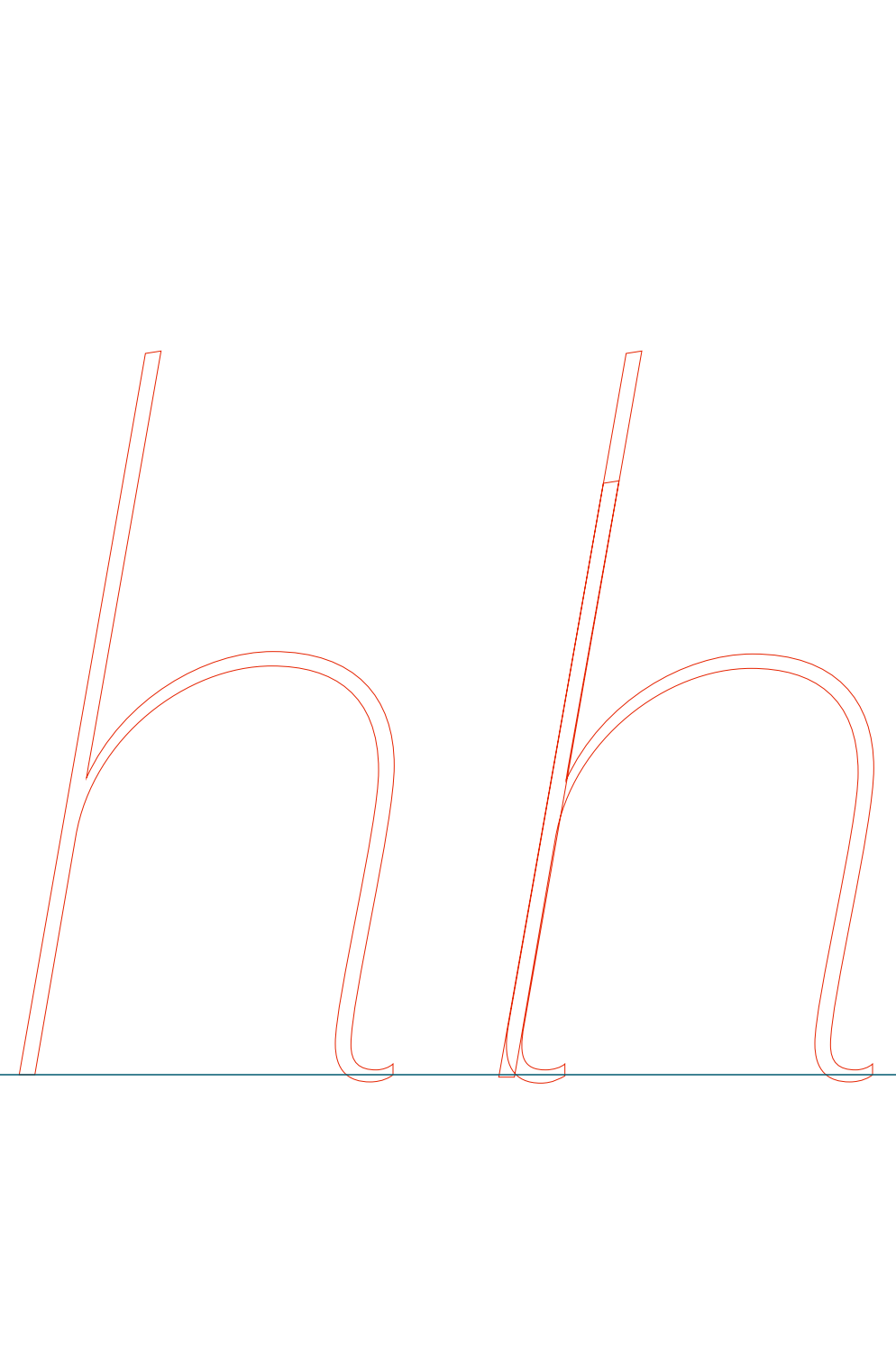
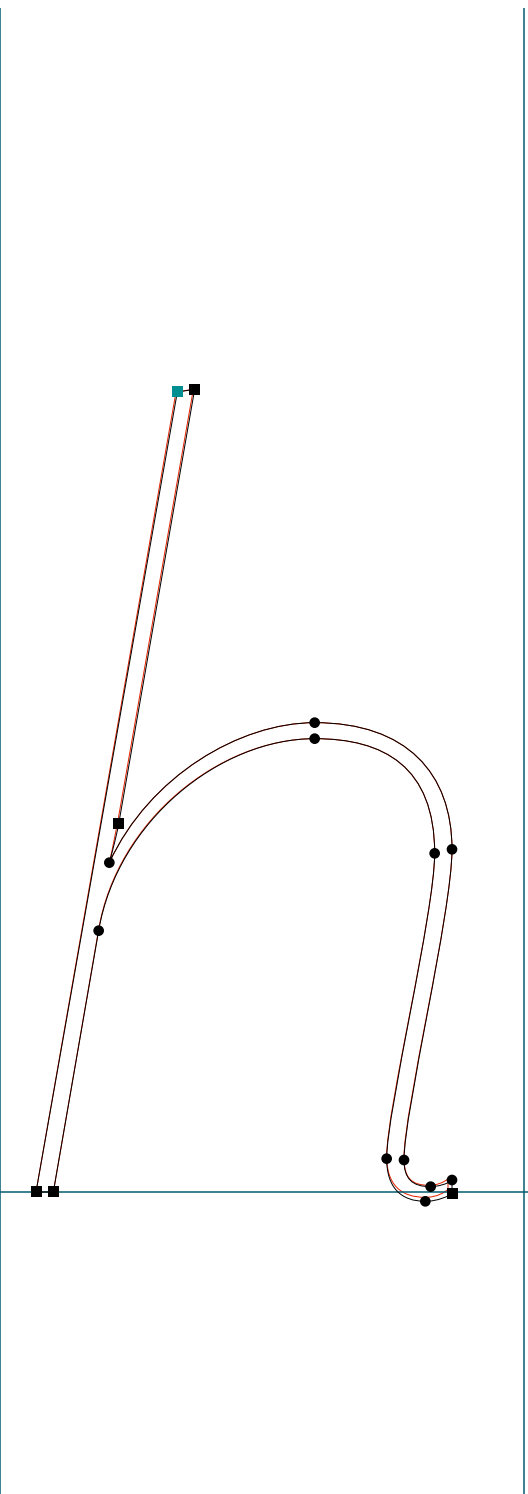

MR EAVES SANS & MODERN

MrEavesSan TI | i | RoboFog Sketches | 2009 | Emigre Fonts

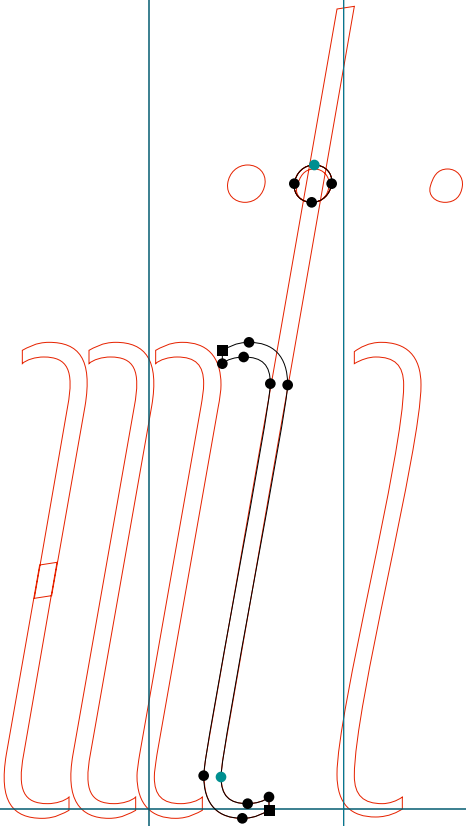

MR EAVES SANS & MODERN

MrEavesSan TI | j | RoboFog Sketches | 2009 | Emigre Fonts

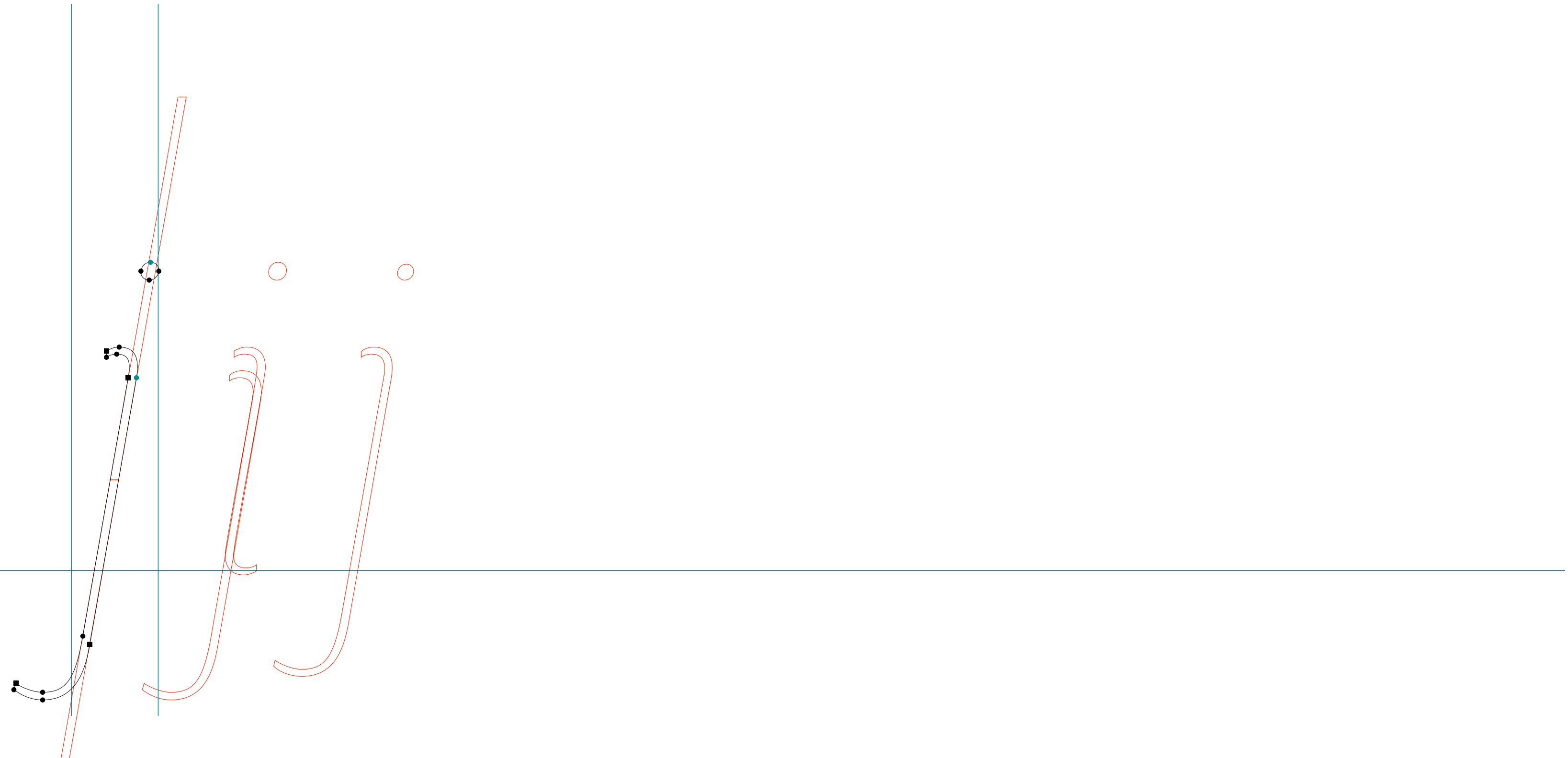

MR EAVES SANS & MODERN

MrEavesSan TI | k | RoboFog Sketches | 2009 | Emigre Fonts

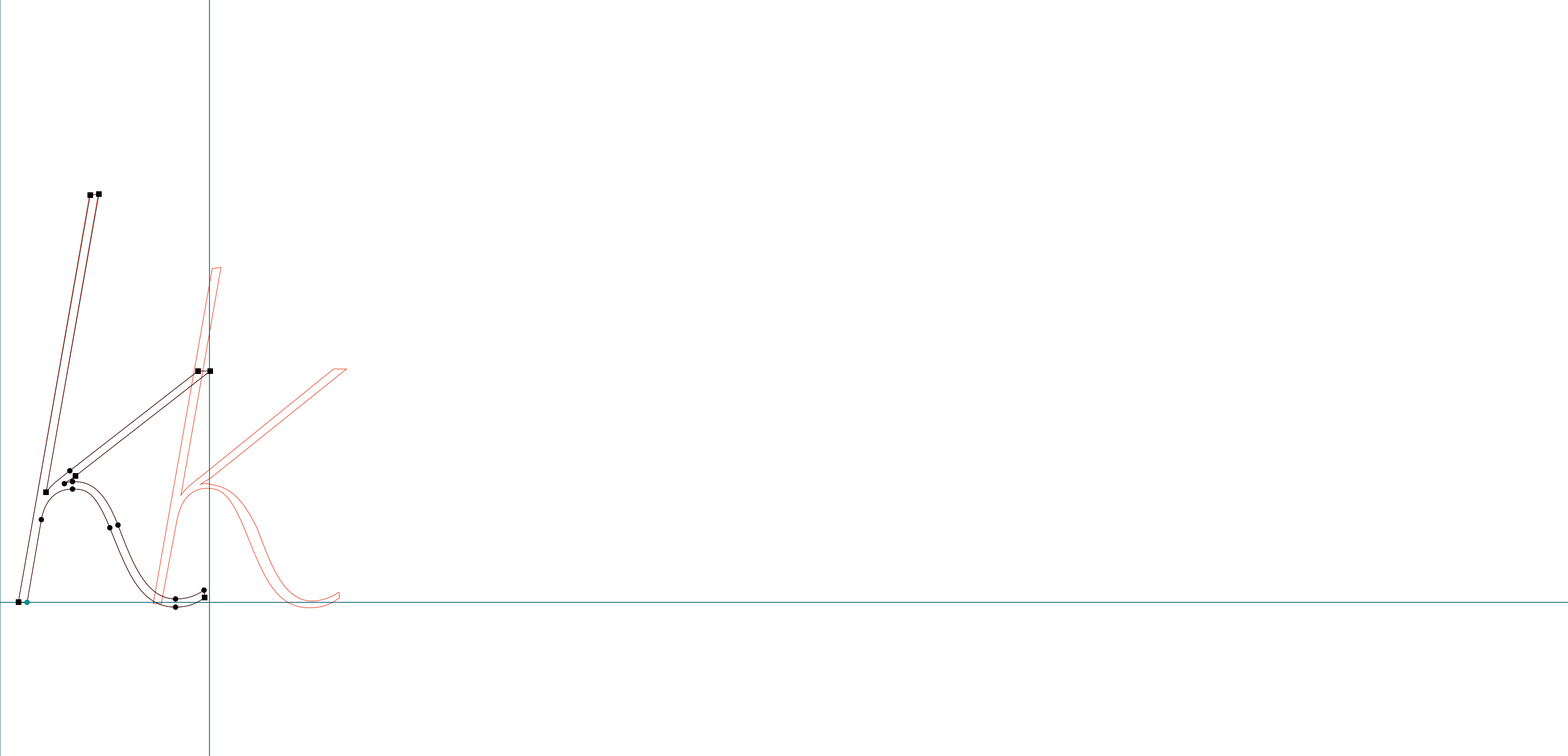

MR EAVES SANS & MODERN

MrEavesSan TI | m | RoboFog Sketches | 2009 | Emigre Fonts

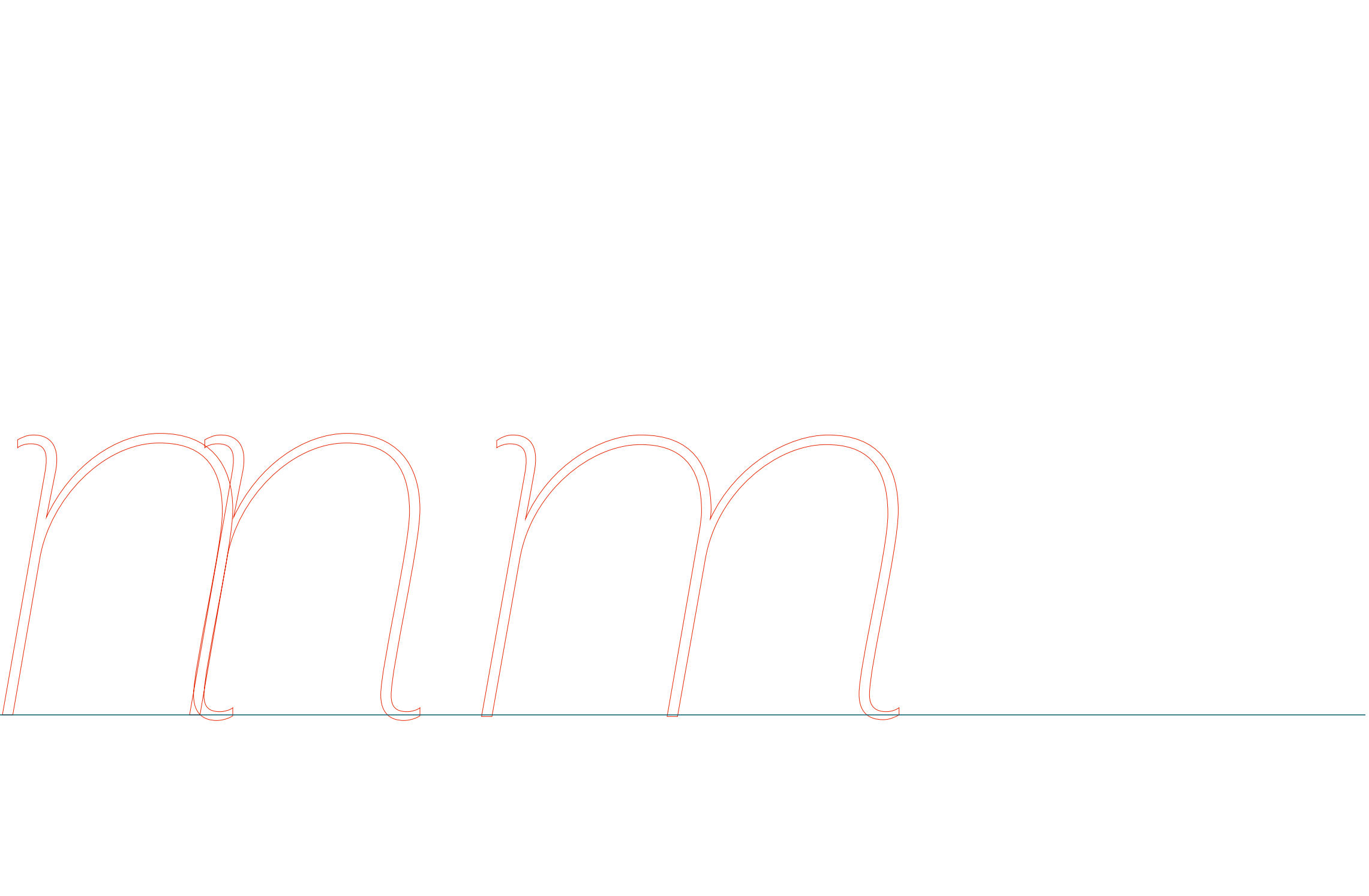
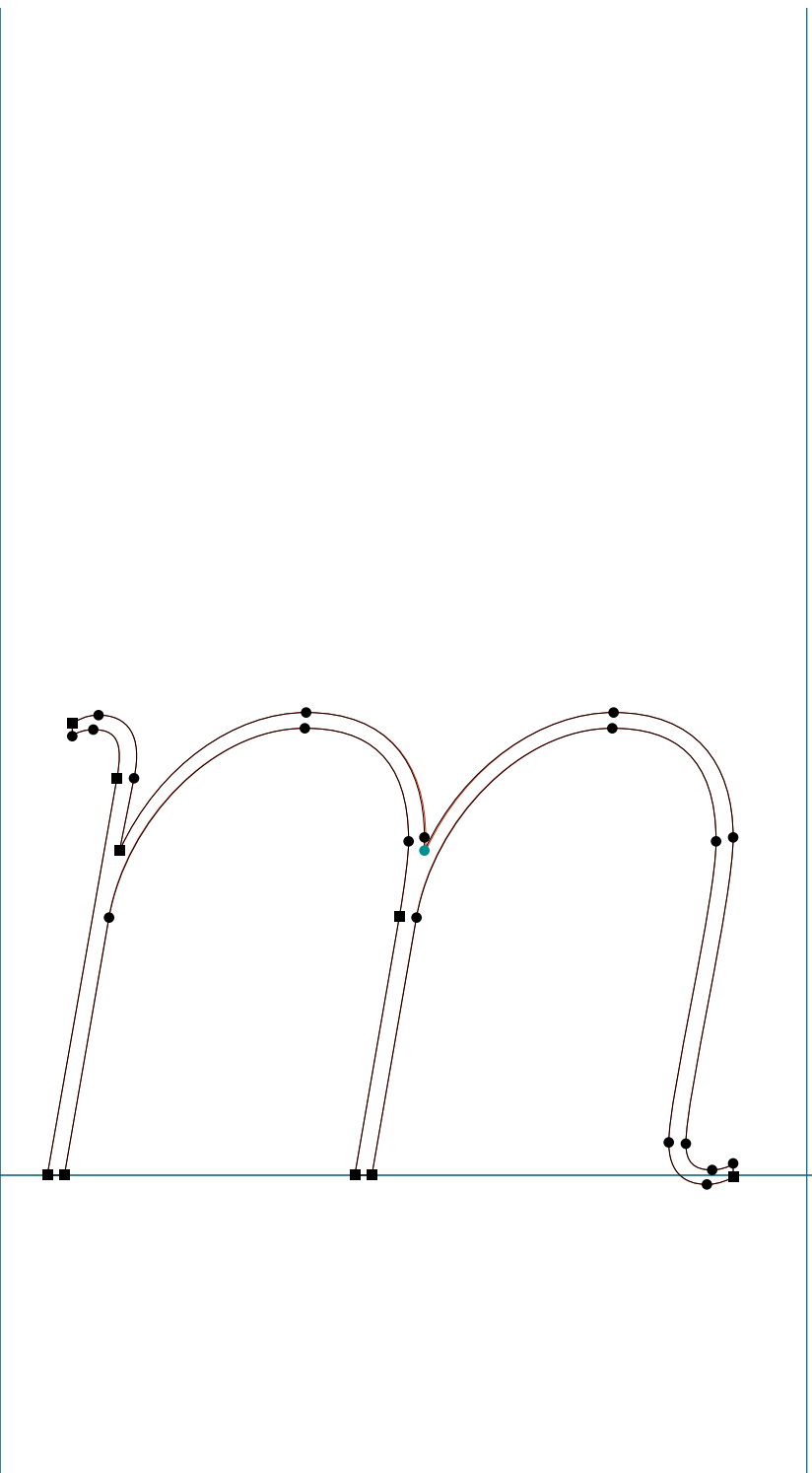

MR EAVES SANS & MODERN

MrEavesSan TI | n | RoboFog Sketches | 2009 | Emigre Fonts

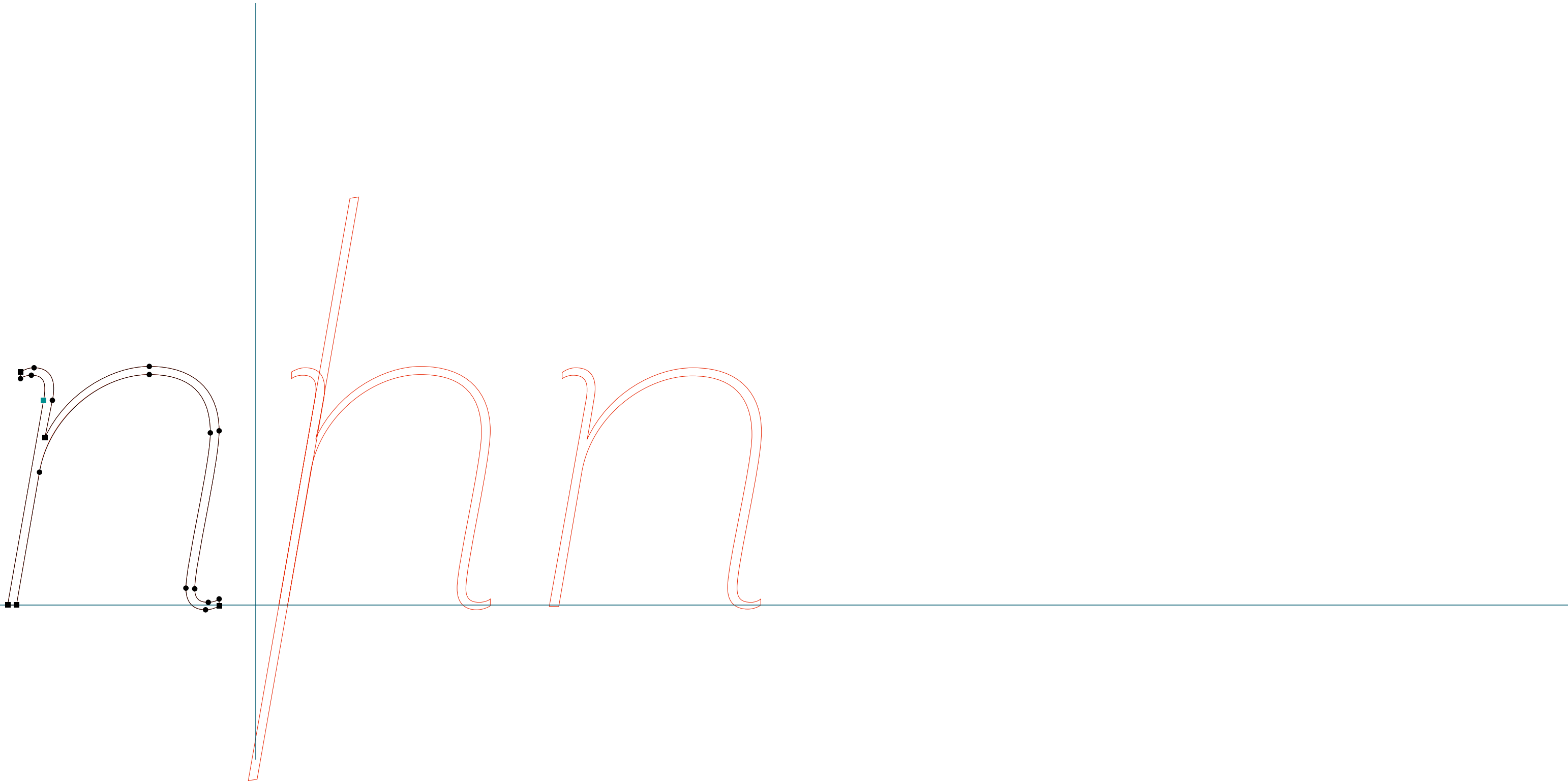

MR EAVES SANS & MODERN

MrEavesSan TI | p | RoboFog Sketches | 2009 | Emigre Fonts

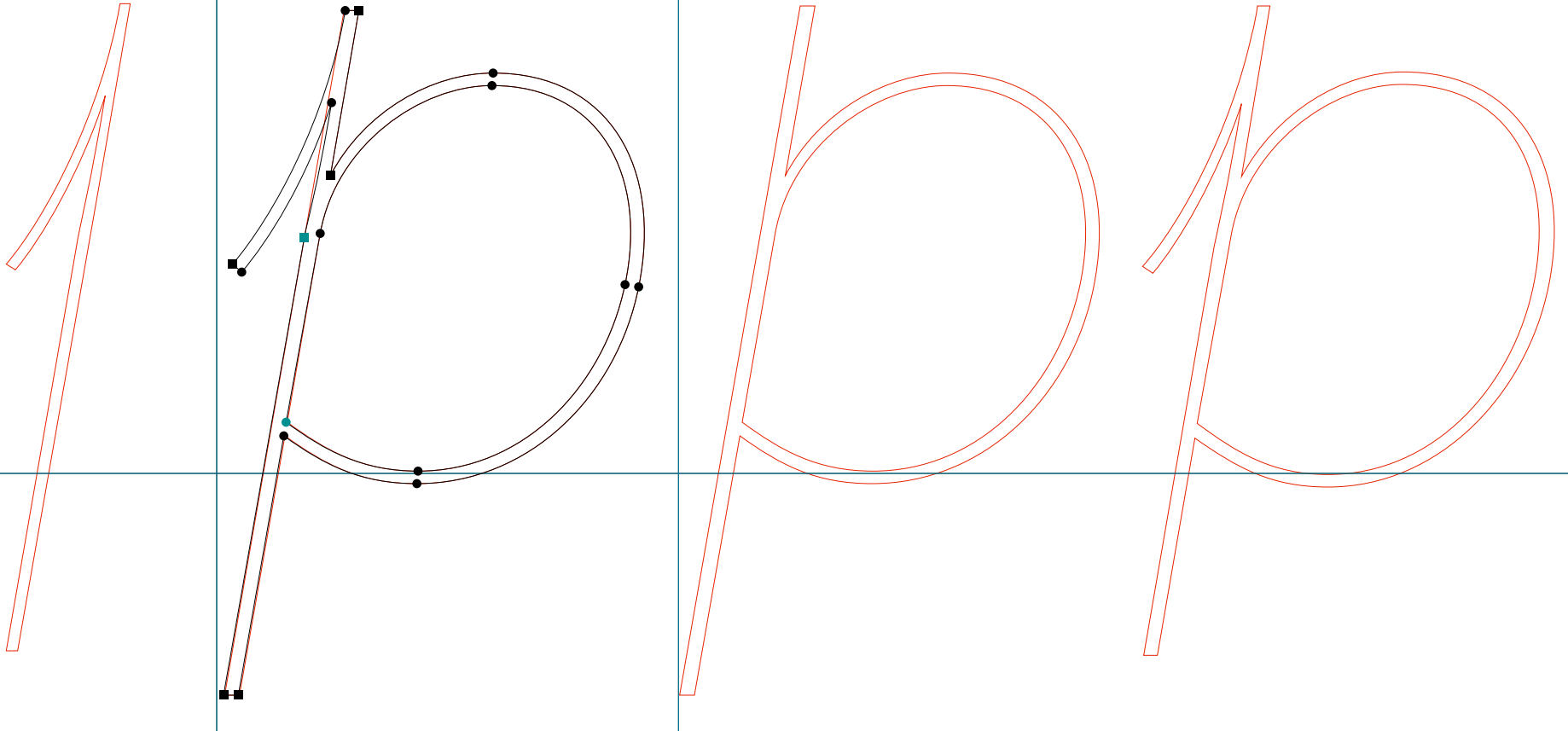

MR EAVES SANS & MODERN

MrEavesSan TI | r | RoboFog Sketches | 2009 | Emigre Fonts

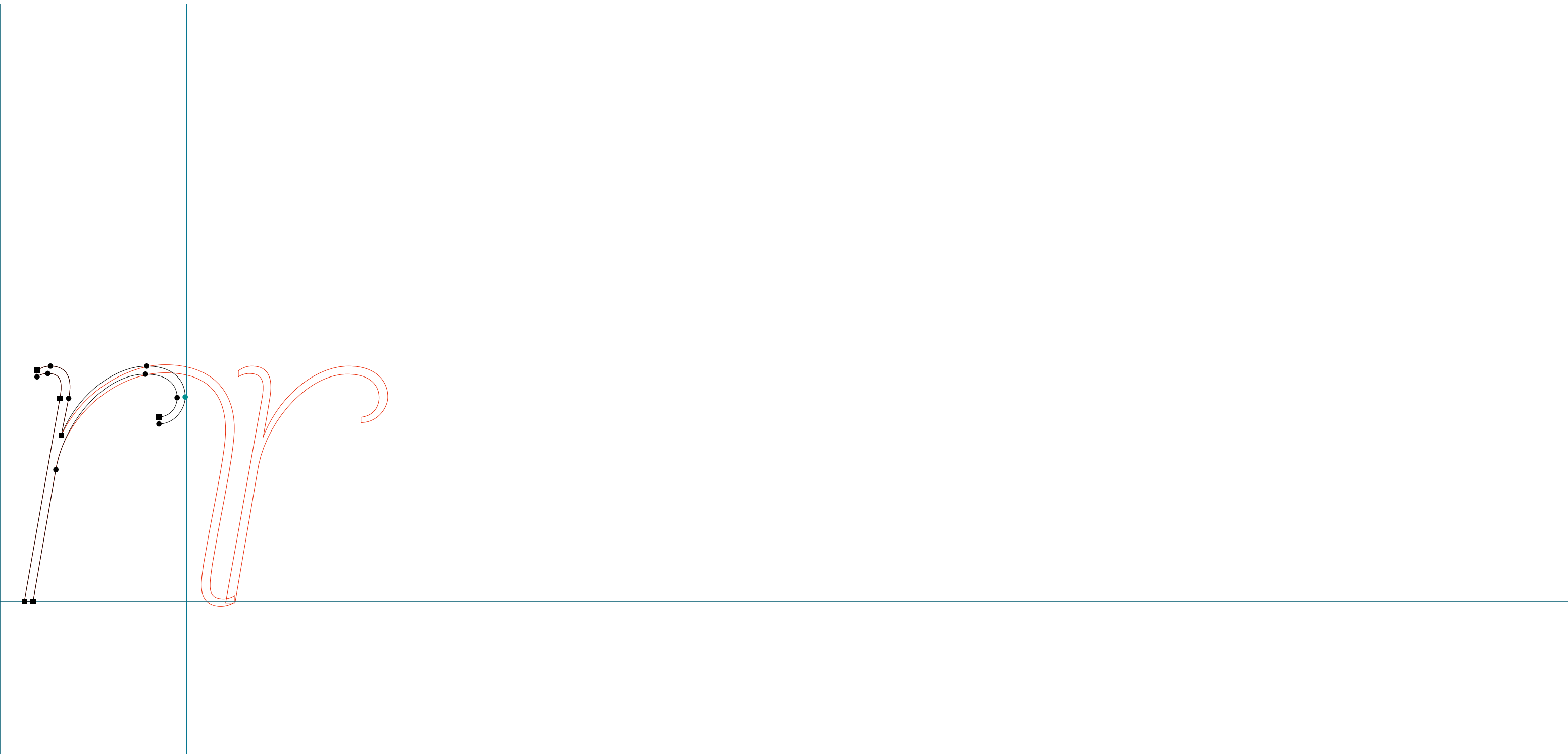

MR EAVES SANS & MODERN

MrEavesSan TI | fl | RoboFog Sketches | 2009 | Emigre Fonts

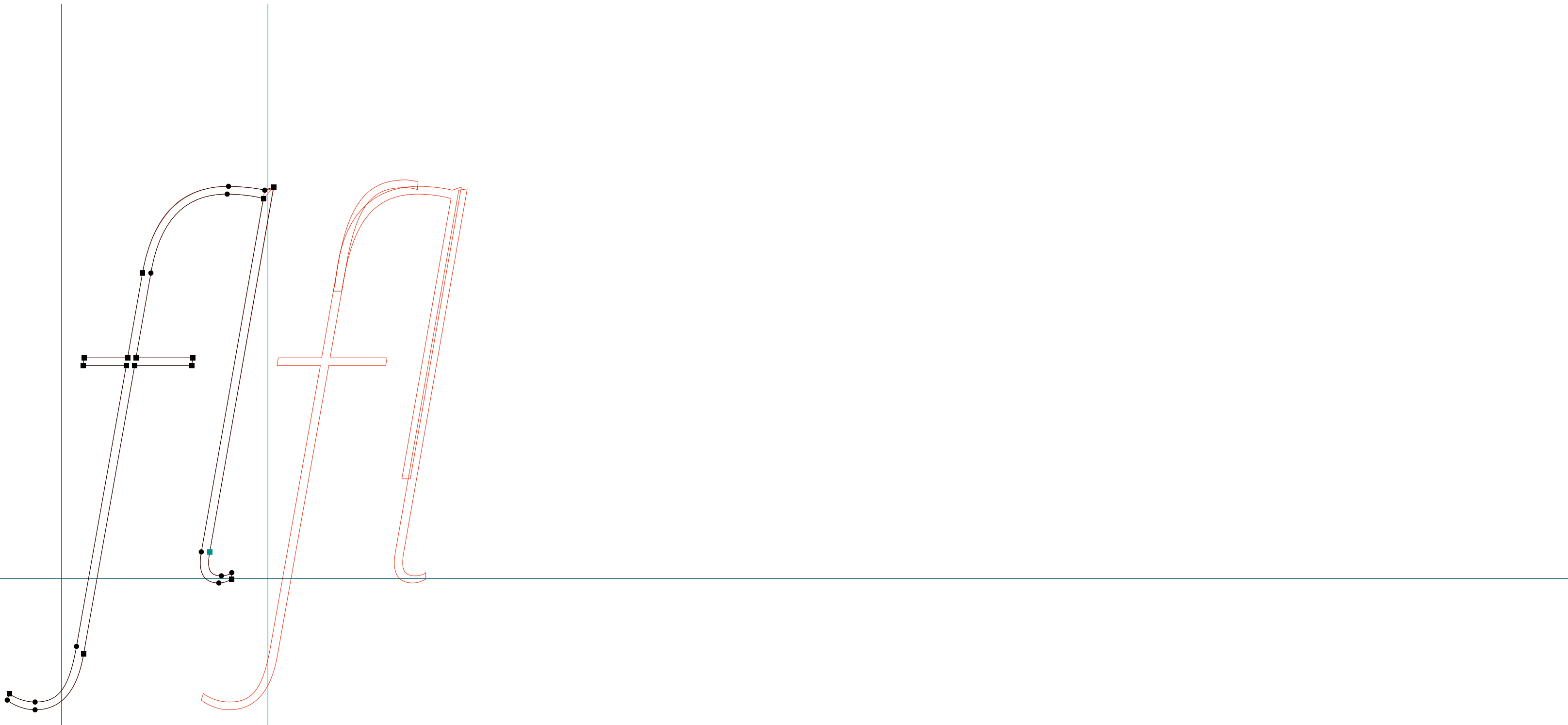

MR EAVES SANS & MODERN

MrEavesSan TI | periodcentered | RoboFog Sketches | 2009 | Emigre Fonts

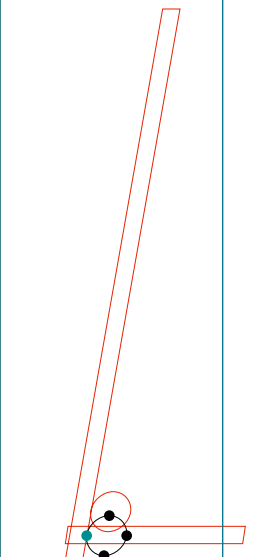

MR EAVES SANS & MODERN

MrEavesSan L | x | RoboFog Sketches | 2009 | Emigre Fonts

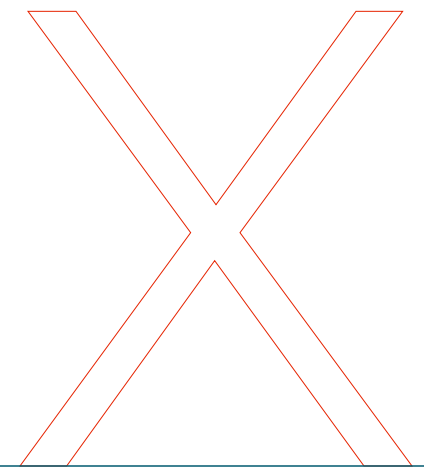
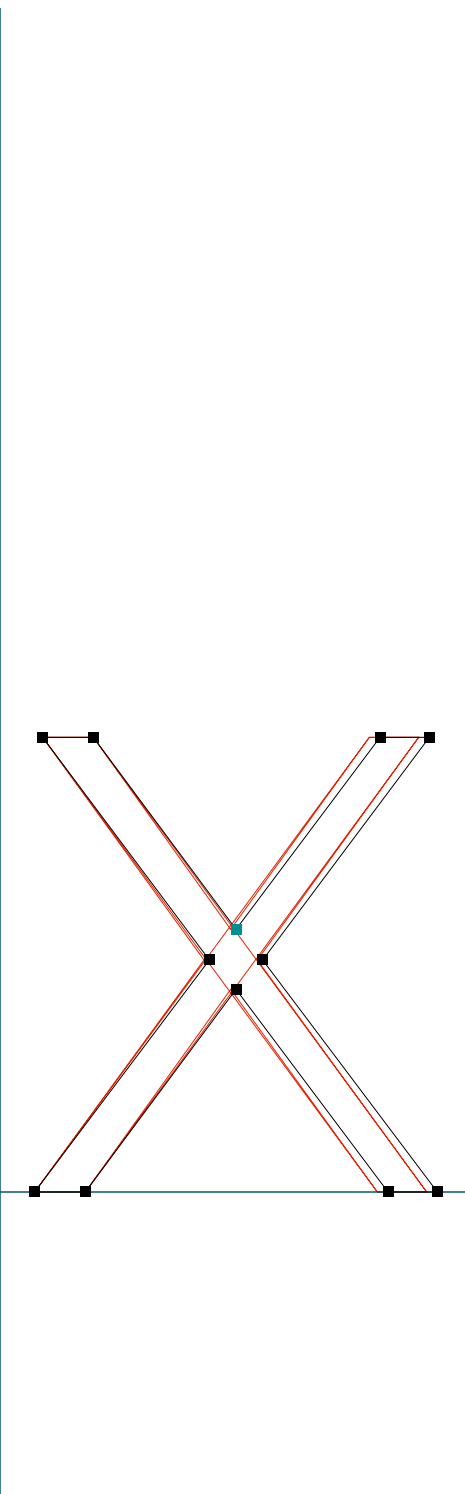

MR EAVES SANS & MODERN

MrEavesSan L | apple | RoboFog Sketches | 2009 | Emigre Fonts

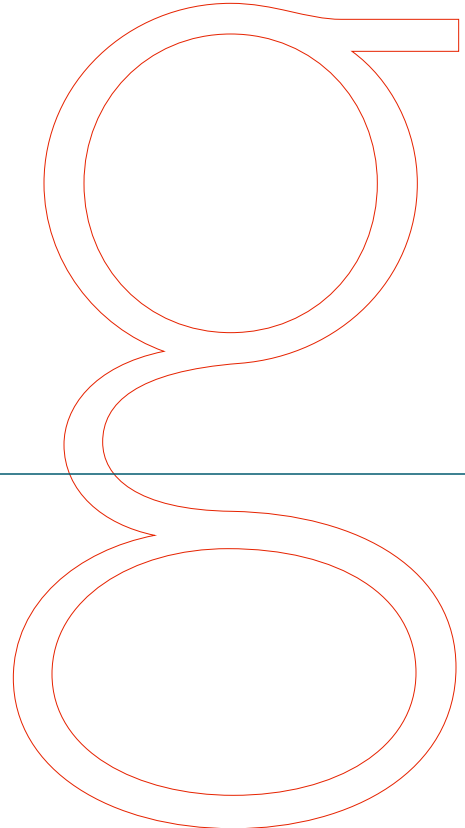
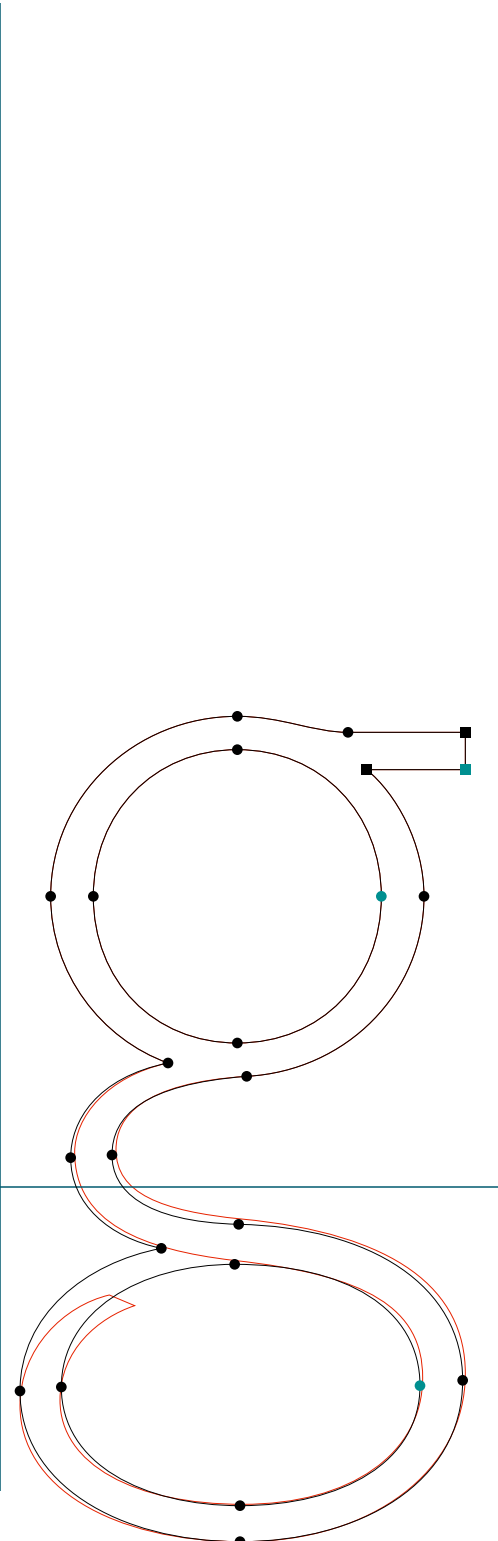

MR EAVES SANS & MODERN

MrEavesSan LI | x | RoboFog Sketches | 2009 | Emigre Fonts

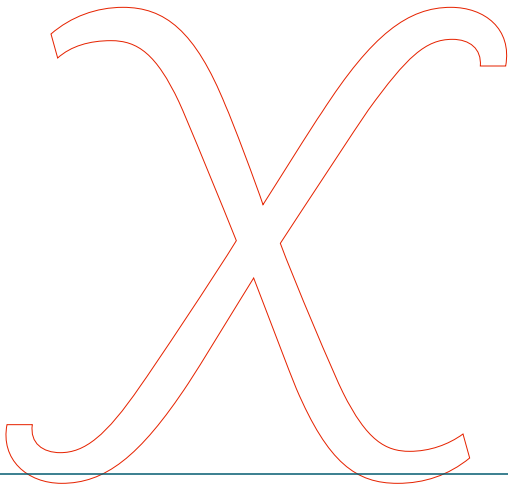
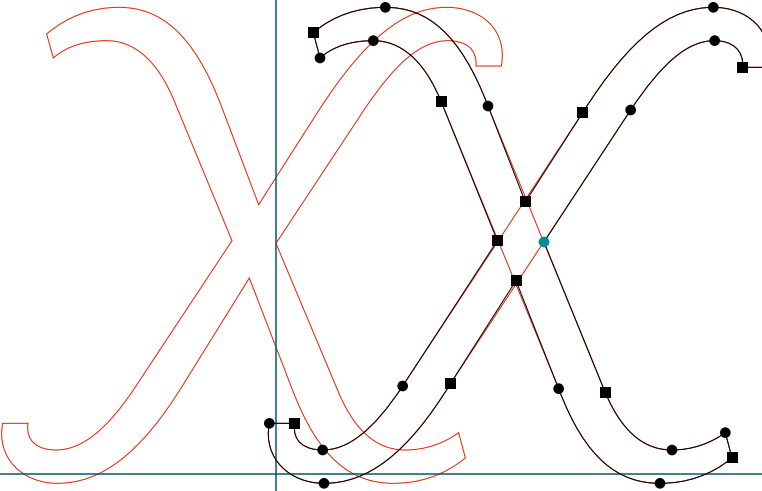

MR EAVES SANS & MODERN

MrEavesSan LI | apple | RoboFog Sketches | 2009 | Emigre Fonts

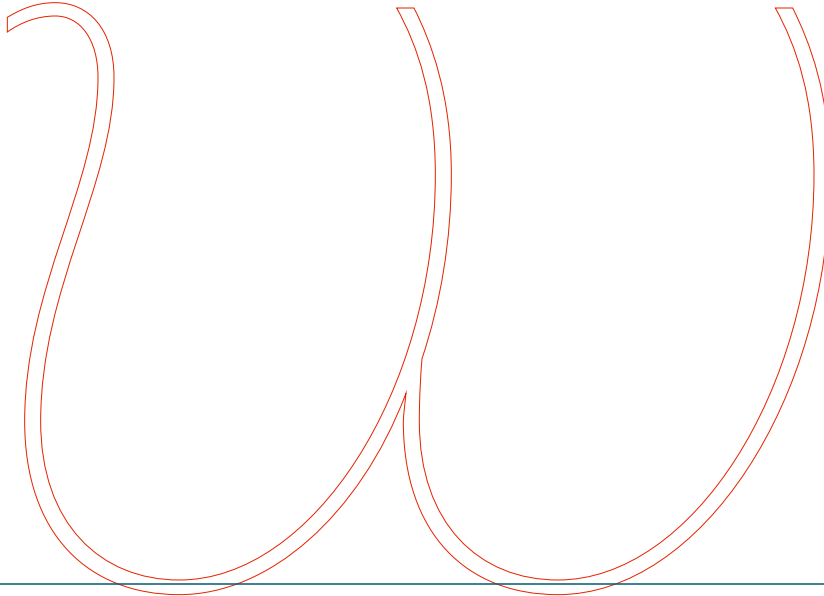

MR EAVES SANS & MODERN

MrEavesSanAlt LI | v | RoboFog Sketches | 2009 | Emigre Fonts

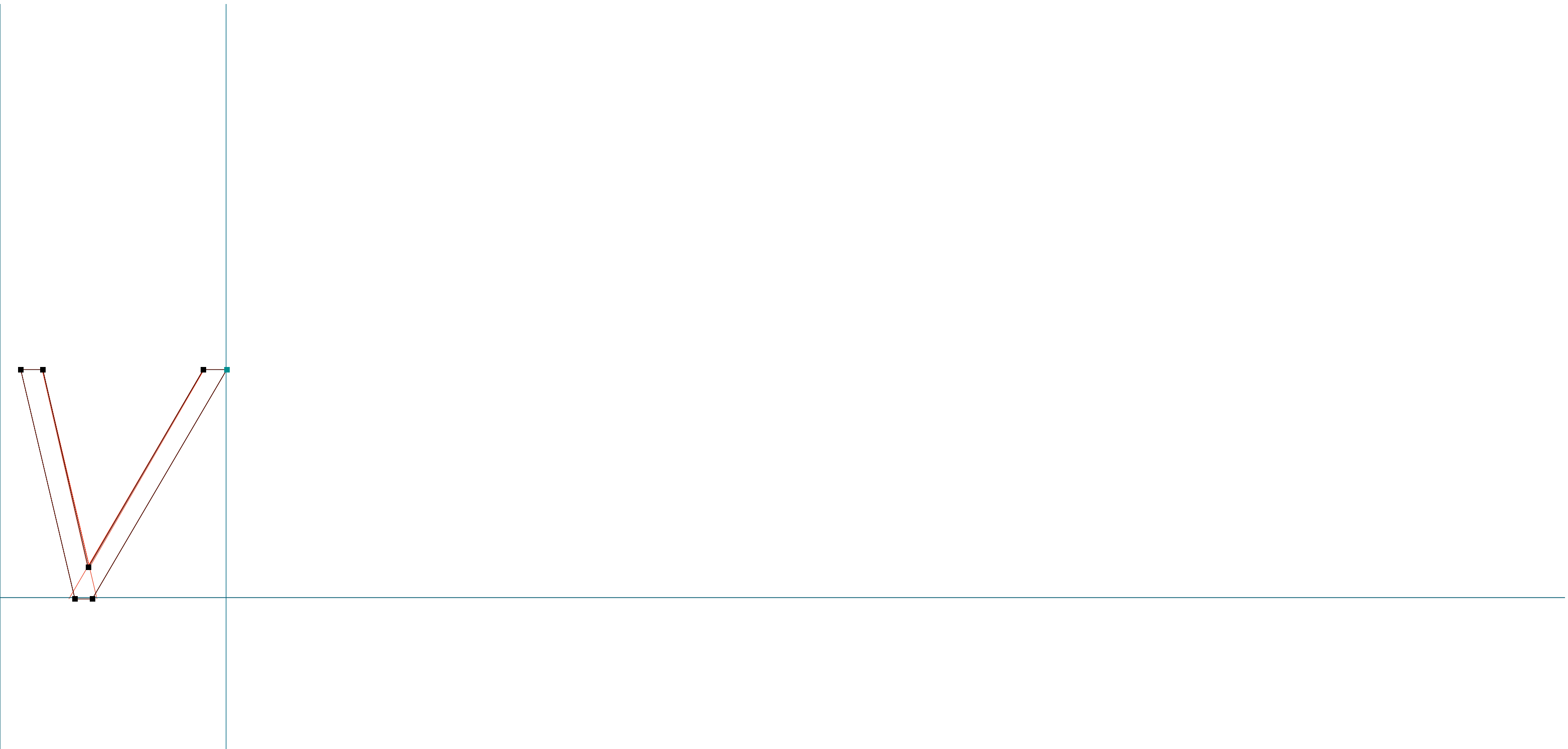

MR EAVES SANS & MODERN

MrEavesSanAlt LI | apple | RoboFog Sketches | 2009 | Emigre Fonts

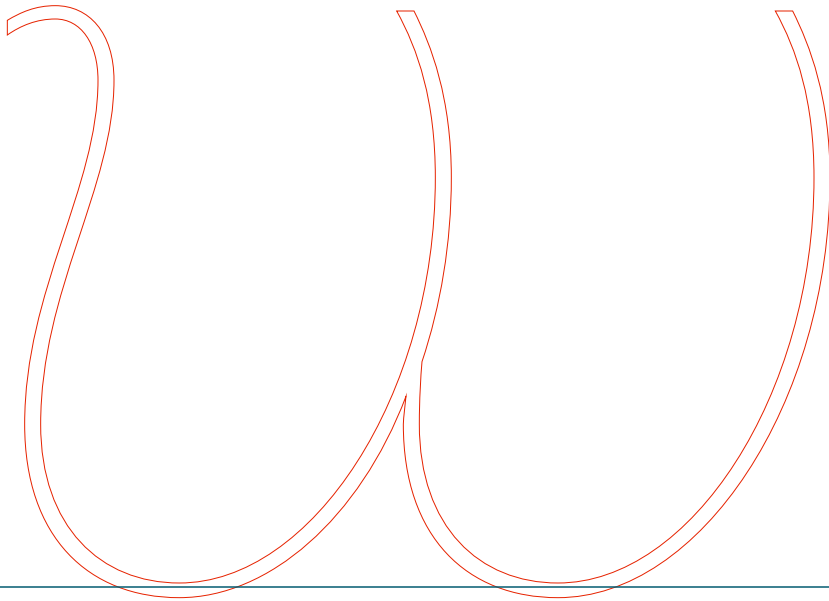

MR EAVES SANS & MODERN

MrEavesSan R | apple | RoboFog Sketches | 2009 | Emigre Fonts

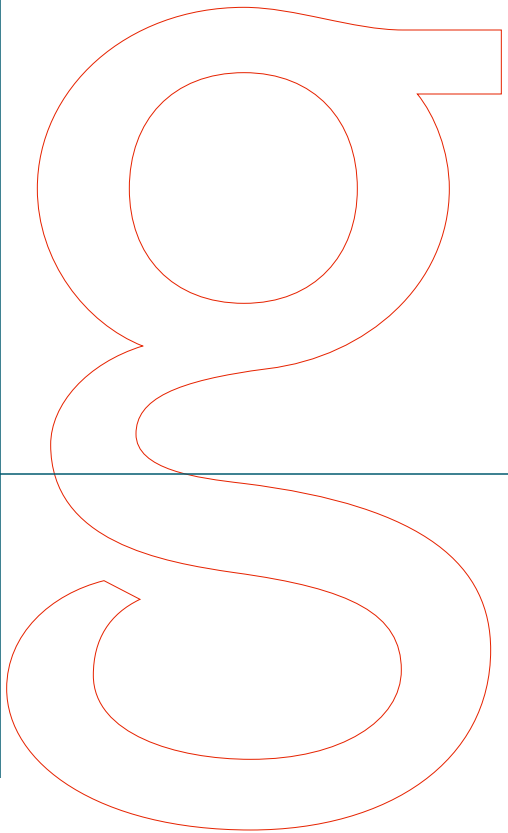
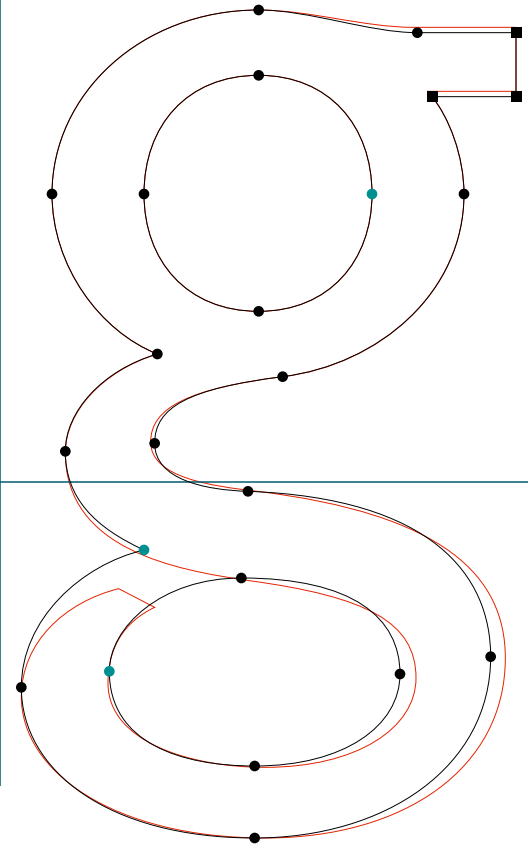
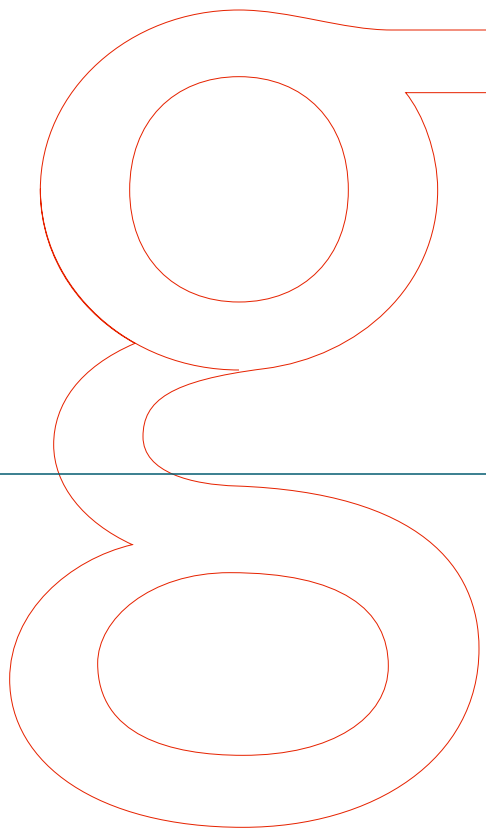

MR EAVES SANS & MODERN

MrEavesSan RI | hyphen | RoboFog Sketches | 2009 | Emigre Fonts

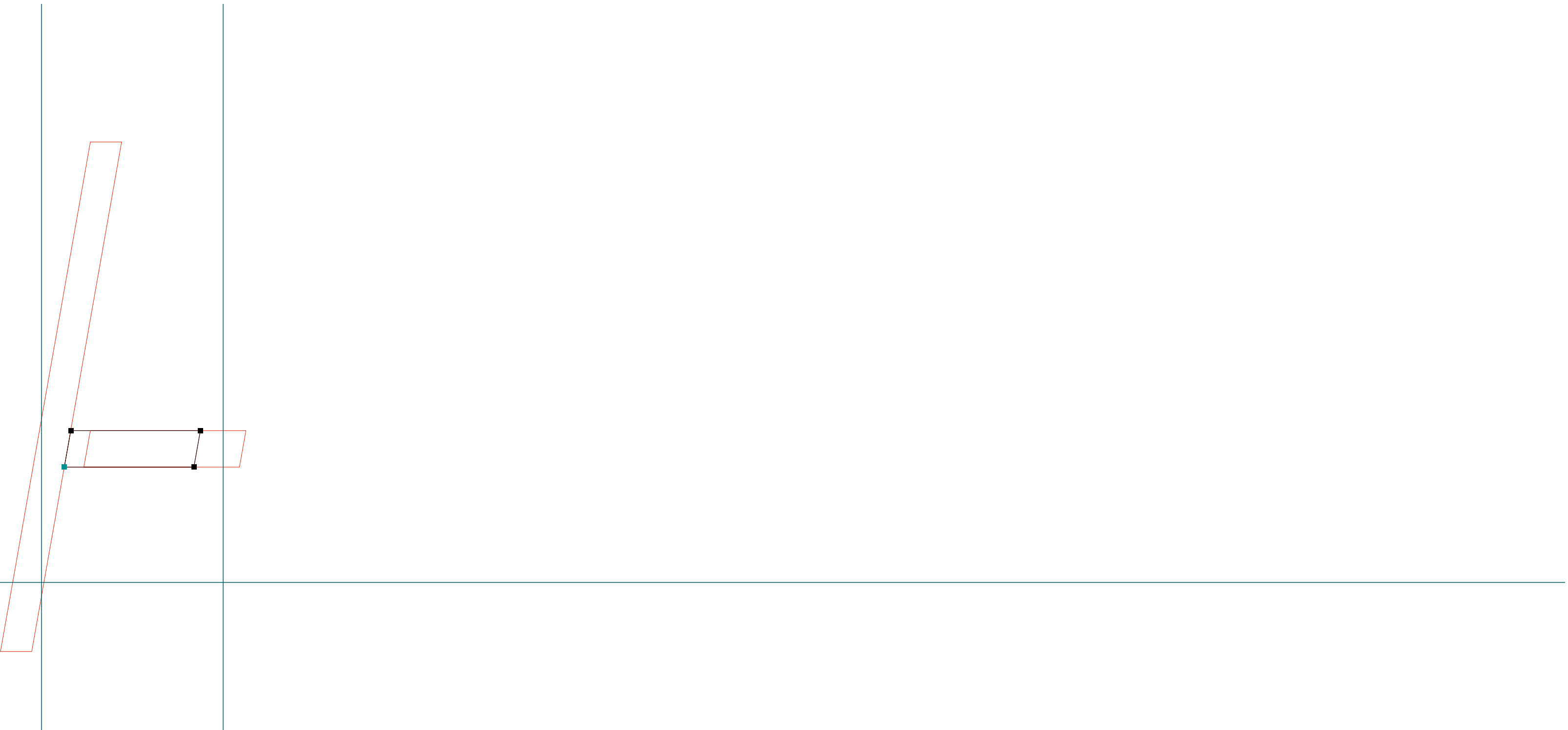

MR EAVES SANS & MODERN

MrEavesSan RI | c | RoboFog Sketches | 2009 | Emigre Fonts

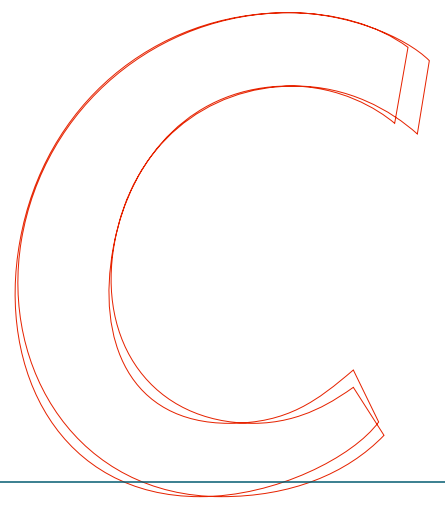
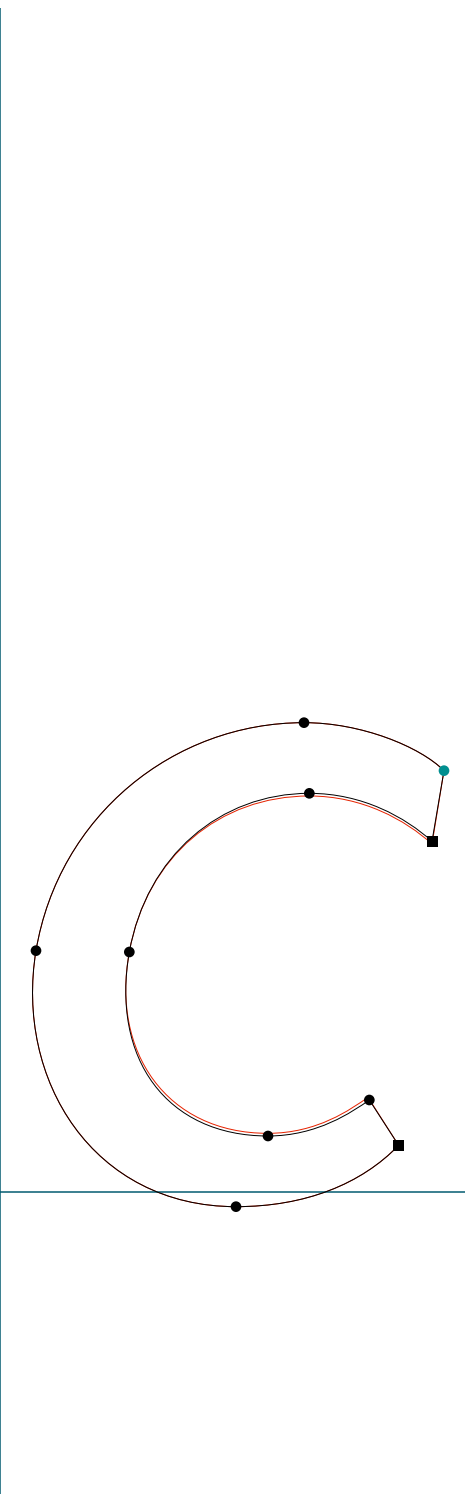

MR EAVES SANS & MODERN

MrEavesSan RI | z | RoboFog Sketches | 2009 | Emigre Fonts

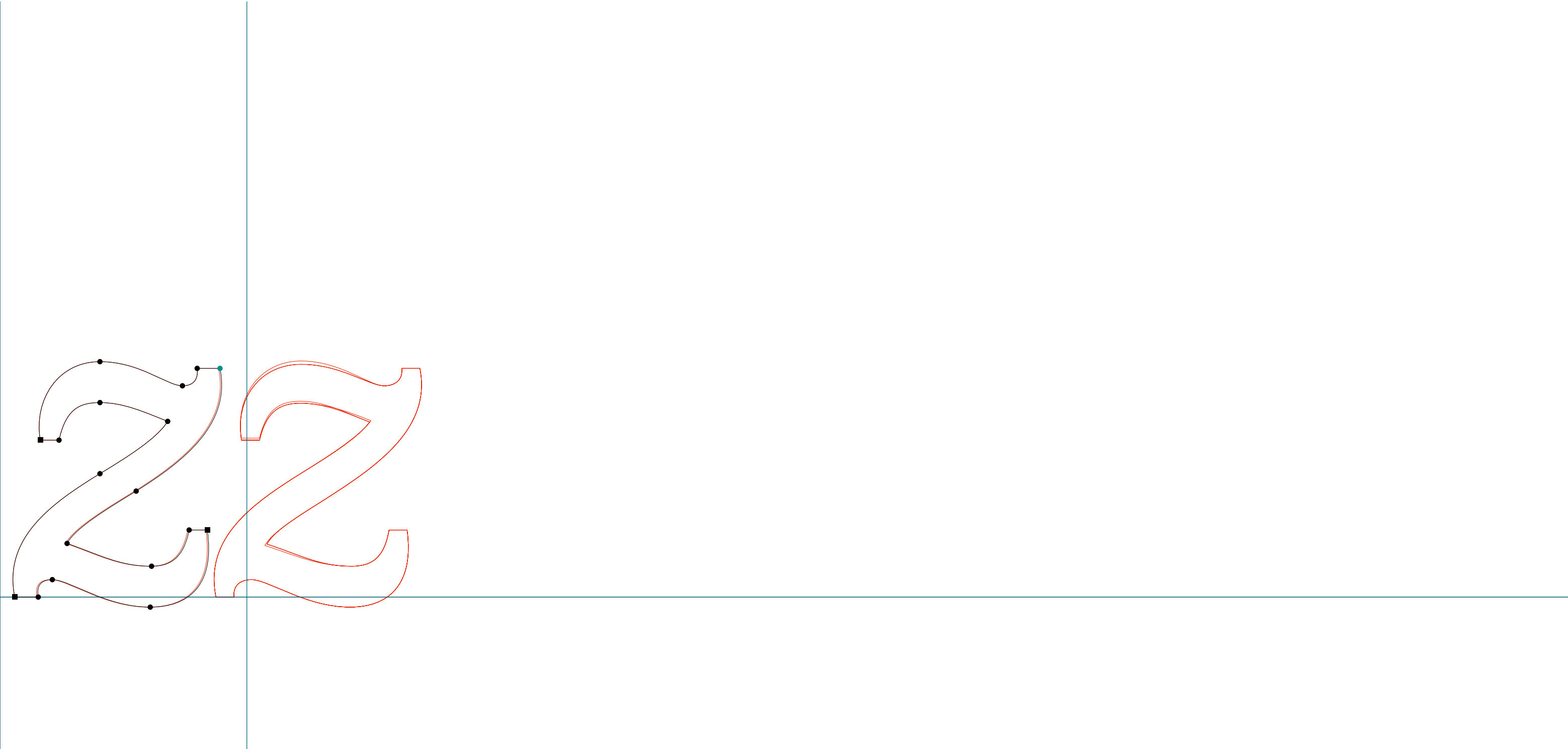

MR EAVES SANS & MODERN

MrEavesSan RI | apple | RoboFog Sketches | 2009 | Emigre Fonts

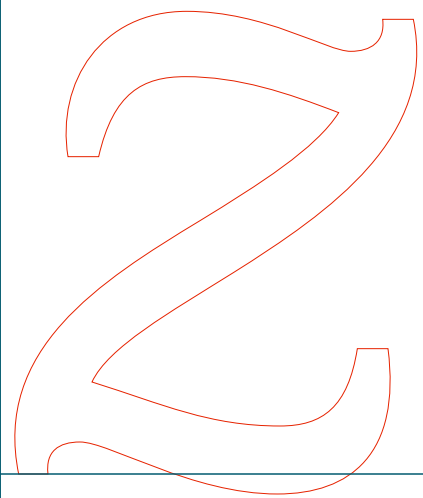

Z

MR EAVES SANS & MODERN

MrEavesSanAlt RI | Q | RoboFog Sketches | 2009 | Emigre Fonts

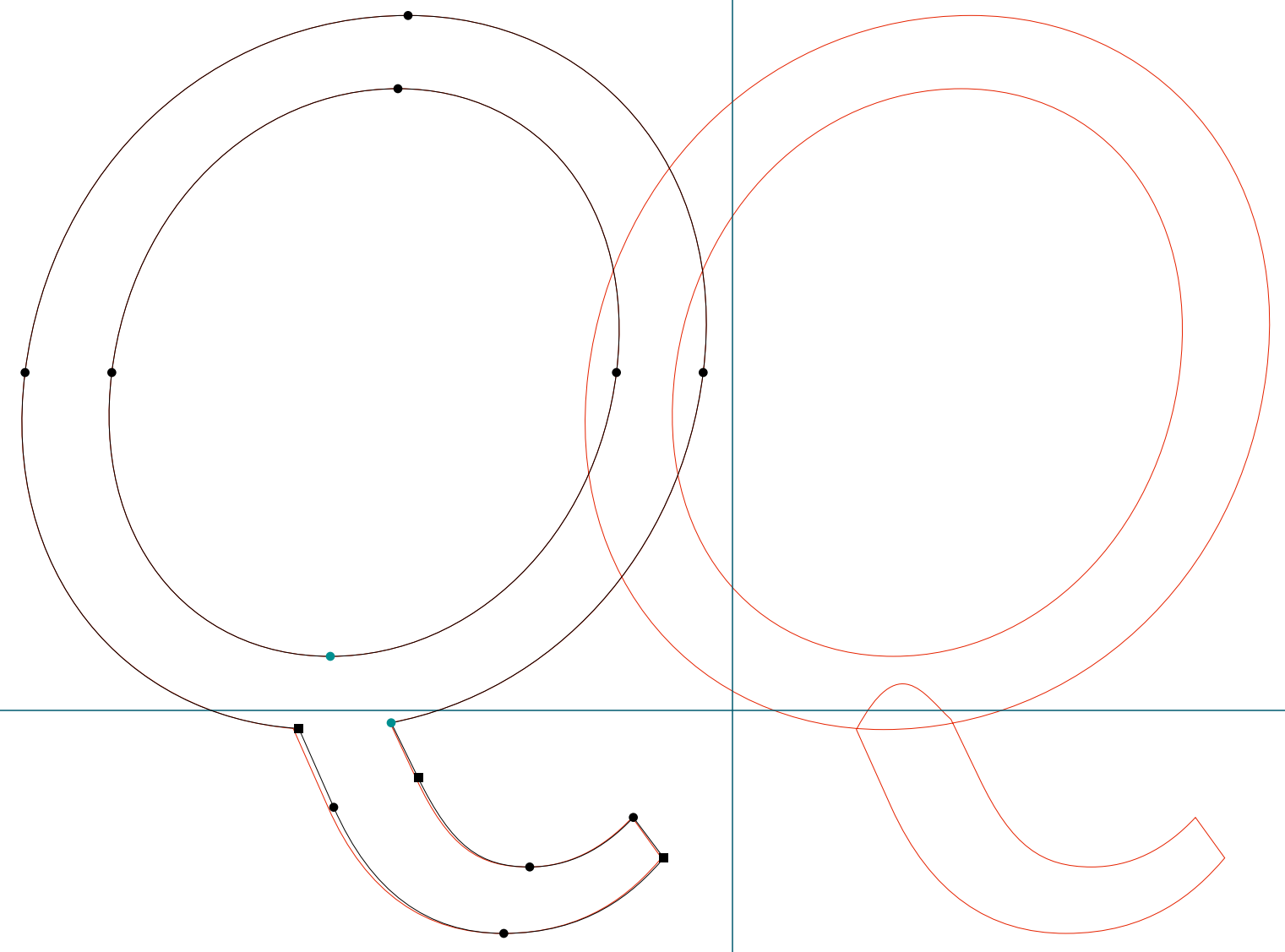

MR EAVES SANS & MODERN

MrEavesSanAlt RI | R | RoboFog Sketches | 2009 | Emigre Fonts



MR EAVES SANS & MODERN

MrEavesSanAlt RI | z | RoboFog Sketches | 2009 | Emigre Fonts

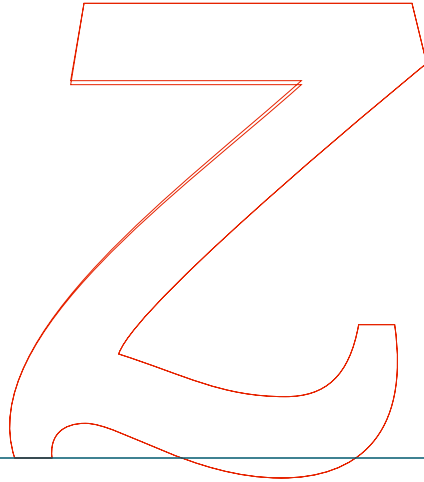
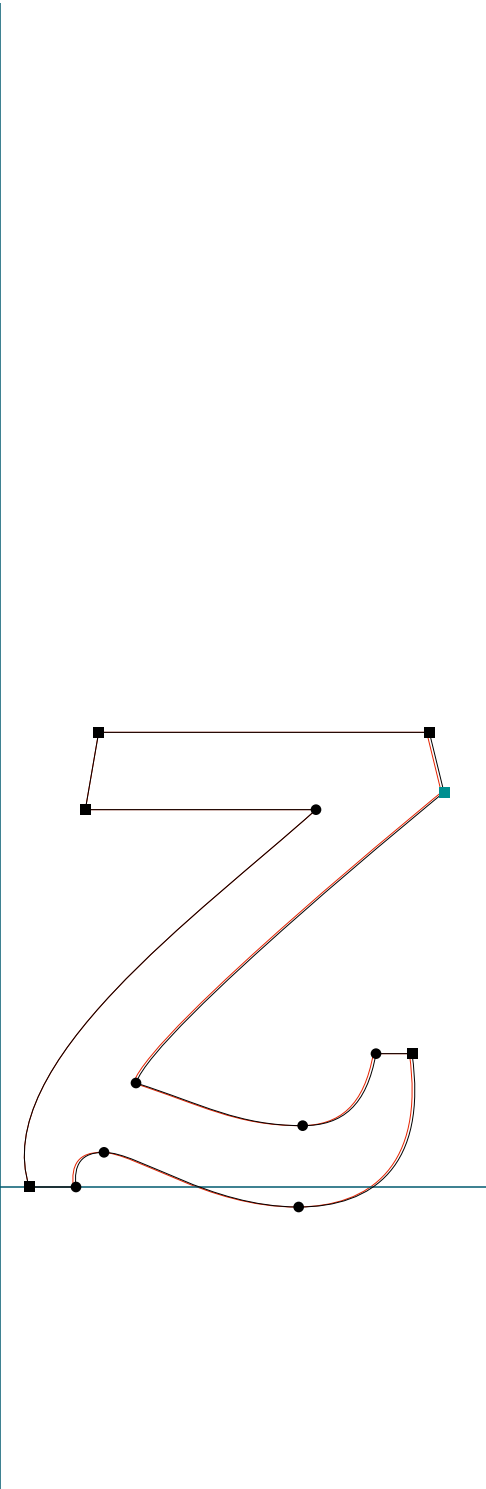

MR EAVES SANS & MODERN

MrEavesSan B | florin | RoboFog Sketches | 2009 | Emigre Fonts

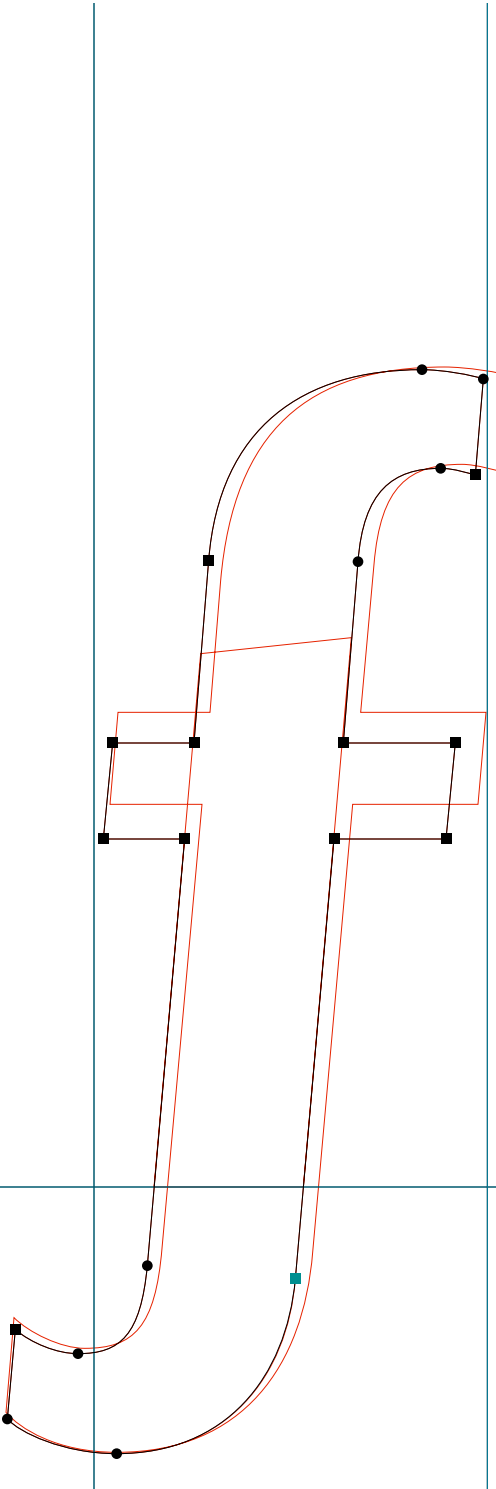

MR EAVES SANS & MODERN

MrEavesSan BI | z | RoboFog Sketches | 2009 | Emigre Fonts

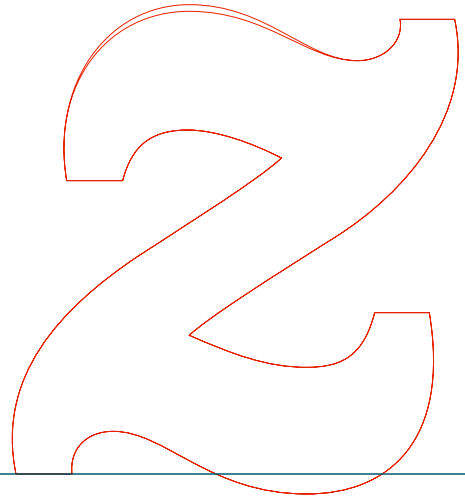
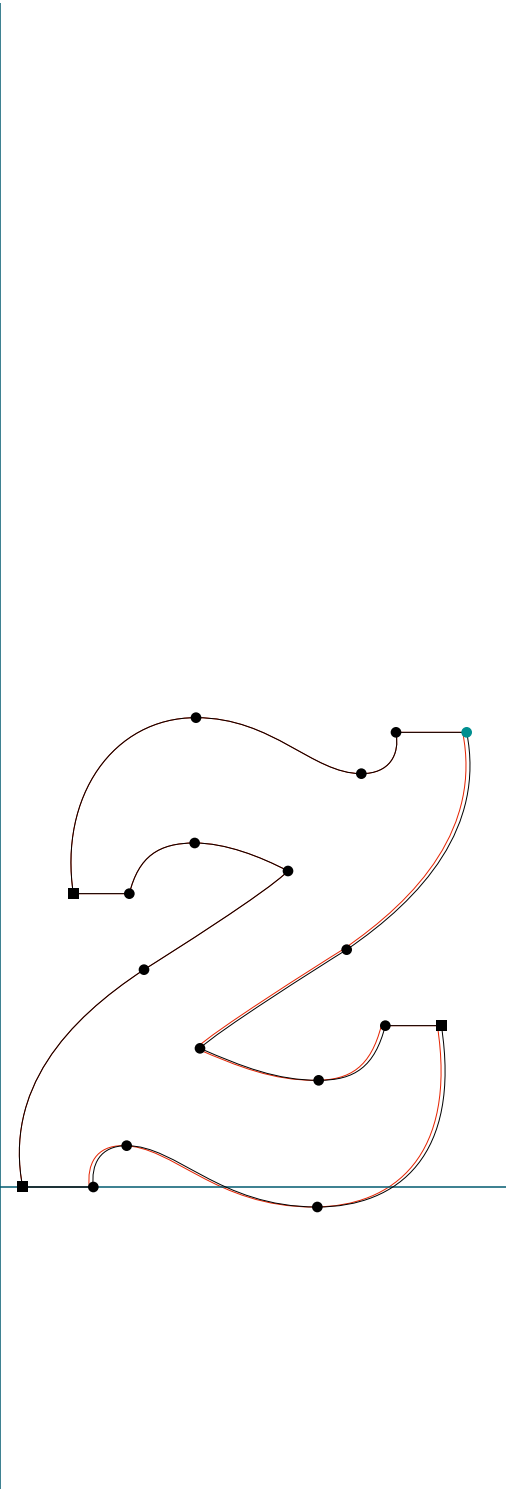

MR EAVES SANS & MODERN

MrEavesSan Bk | DC2 | RoboFog Sketches | 2009 | Emigre Fonts

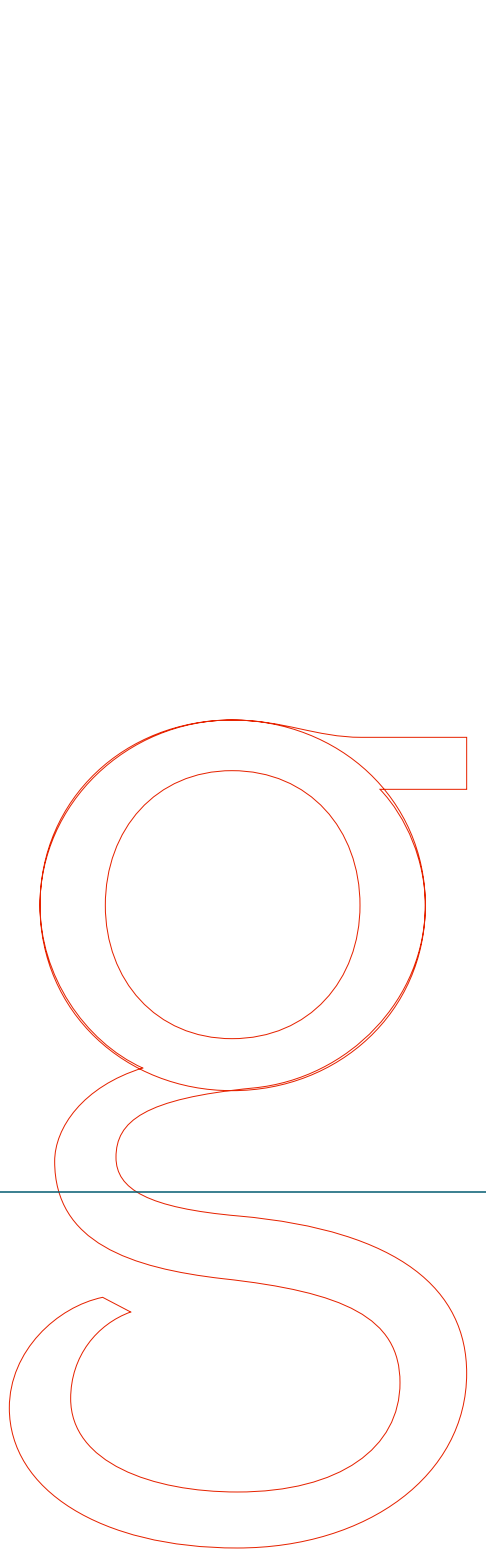
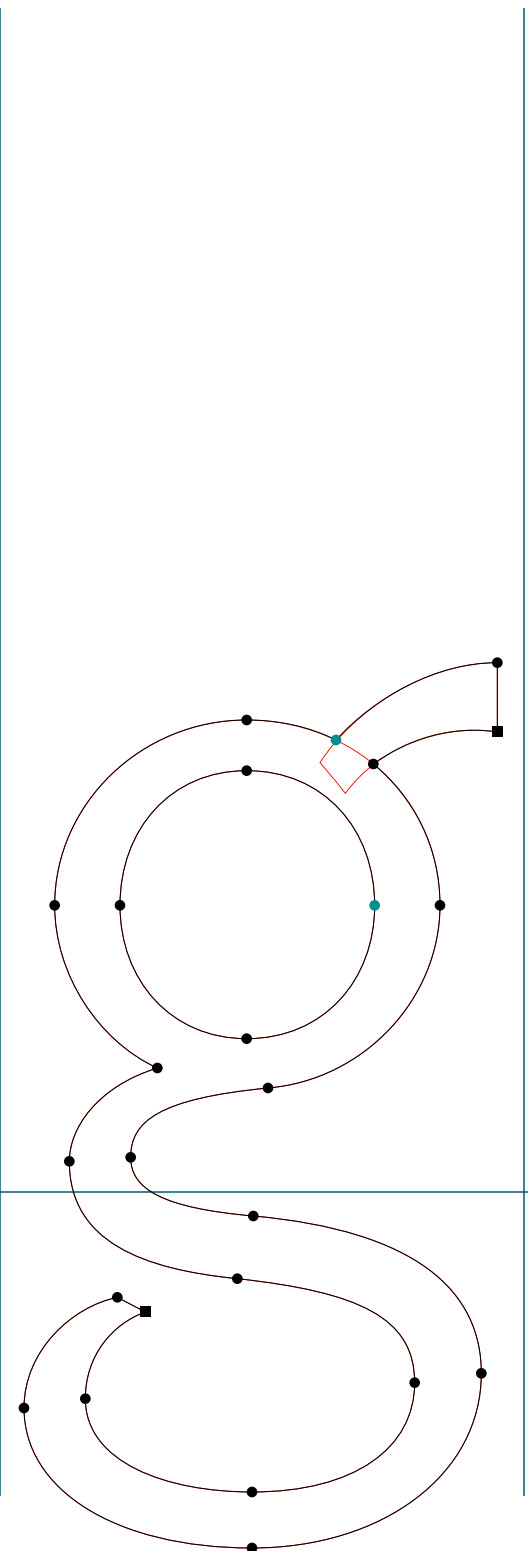

MR EAVES SANS & MODERN

MrEavesSan Bk | DC3 | RoboFog Sketches | 2009 | Emigre Fonts

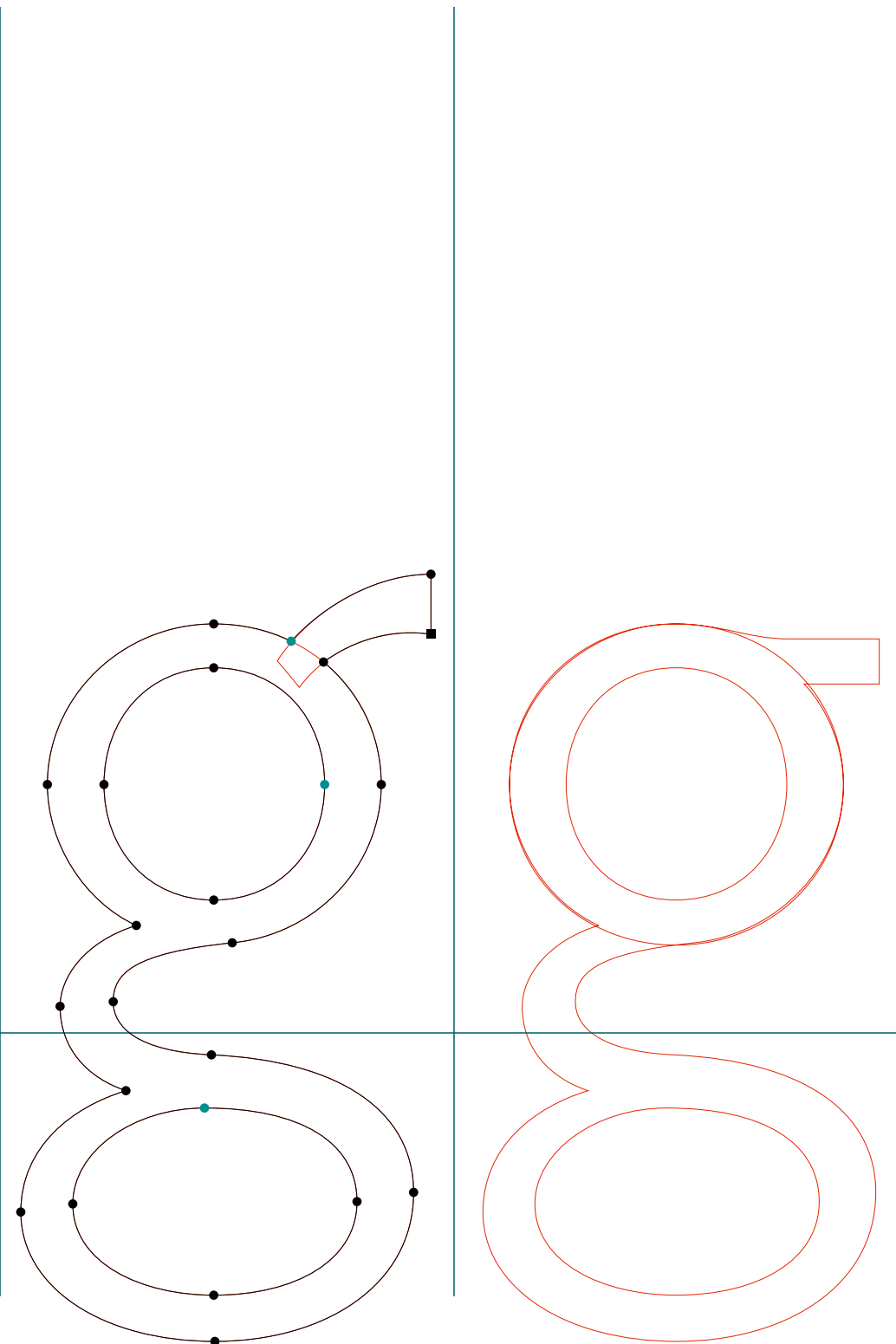

MR EAVES SANS & MODERN

MrEavesSan Bk | Q | RoboFog Sketches | 2009 | Emigre Fonts

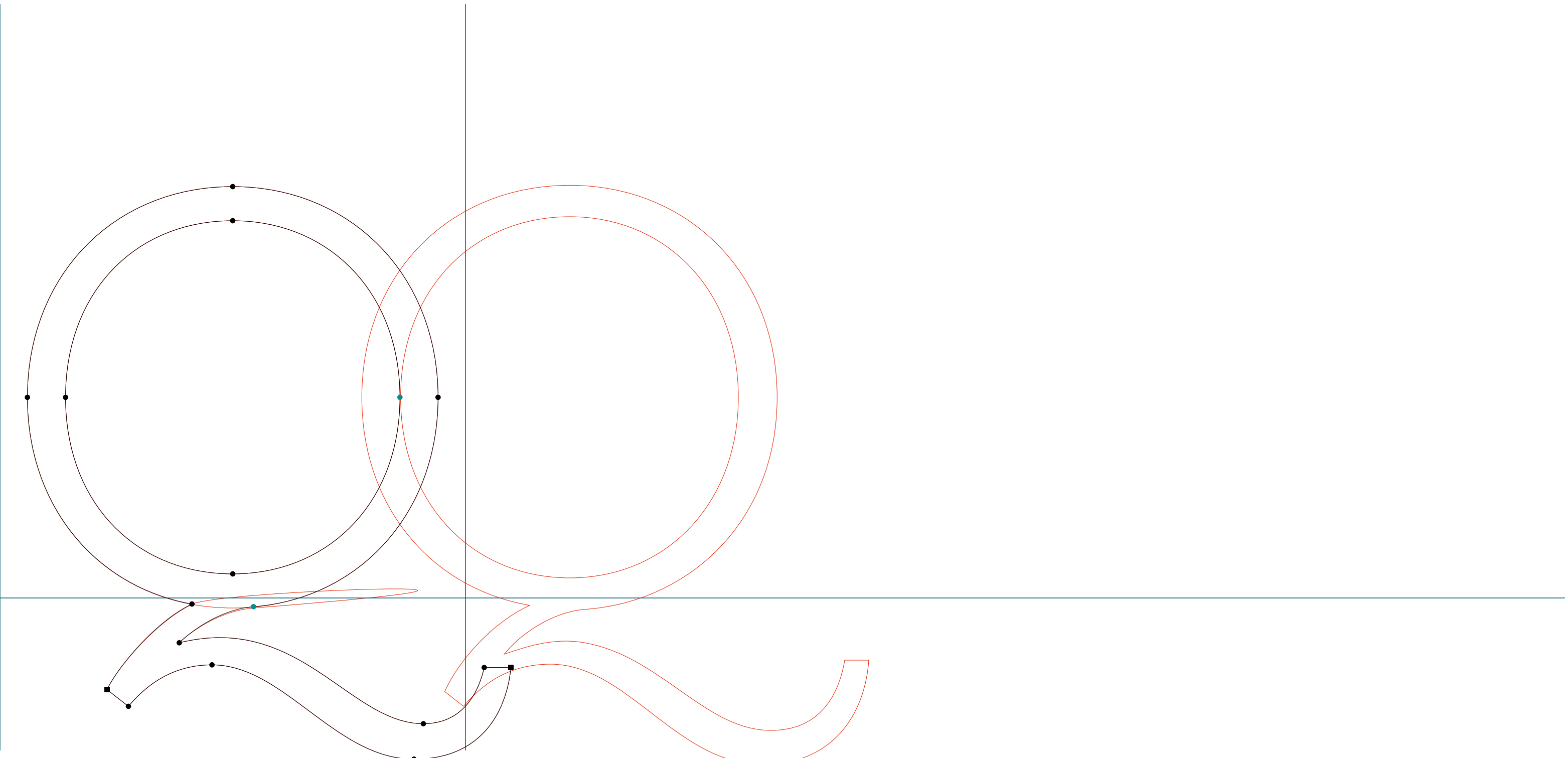

MR EAVES SANS & MODERN

MrEavesSan Bk | k | RoboFog Sketches | 2009 | Emigre Fonts

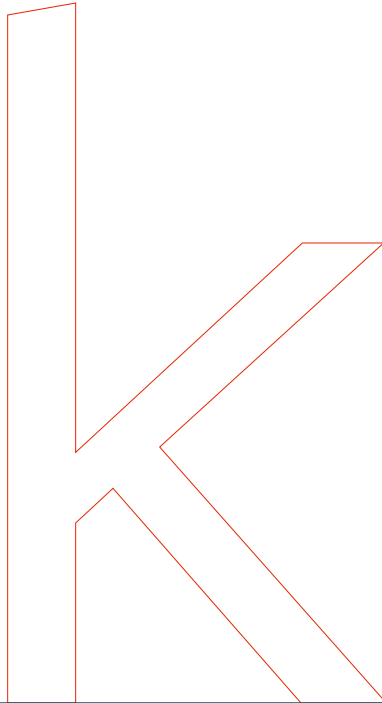
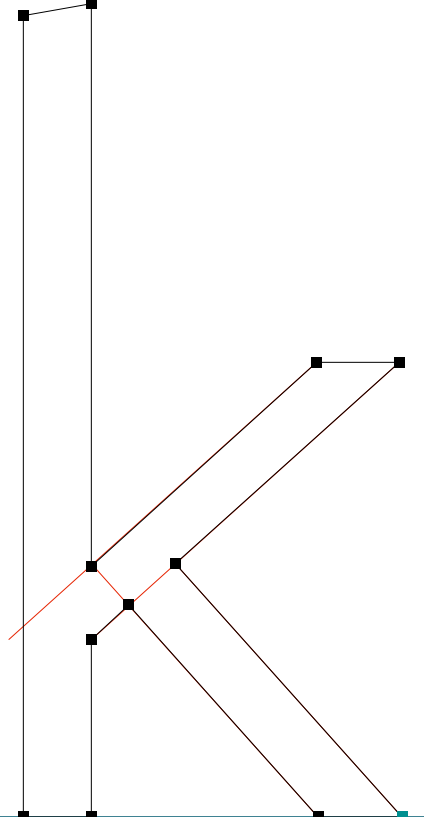
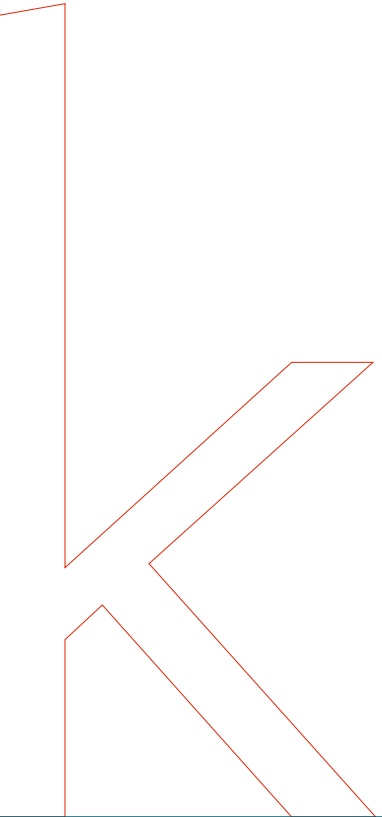

MR EAVES SANS & MODERN

MrEavesSan Bk | y | RoboFog Sketches | 2009 | Emigre Fonts

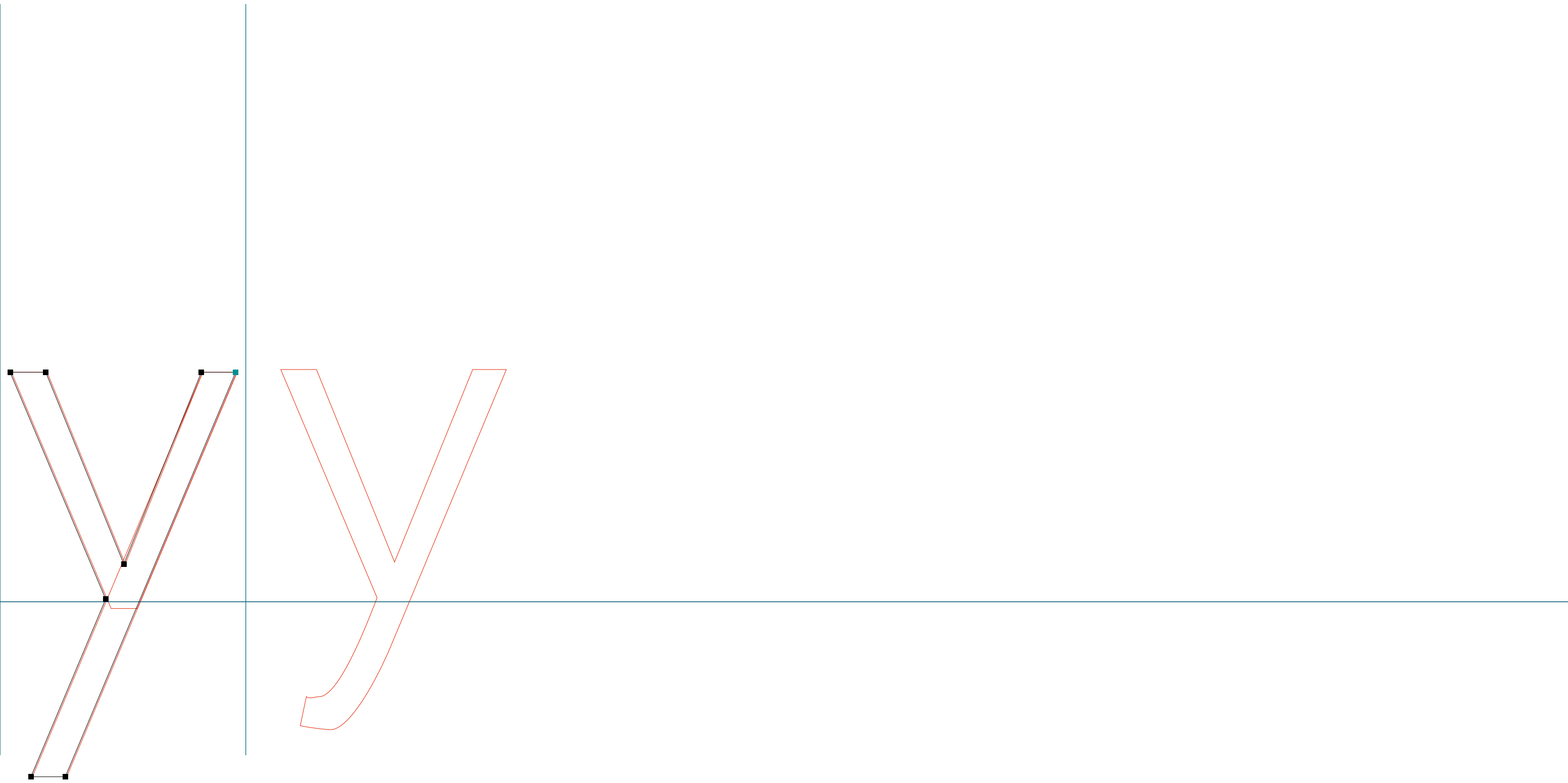

MR EAVES SANS & MODERN

MrEavesSan Bk | summation | RoboFog Sketches | 2009 | Emigre Fonts

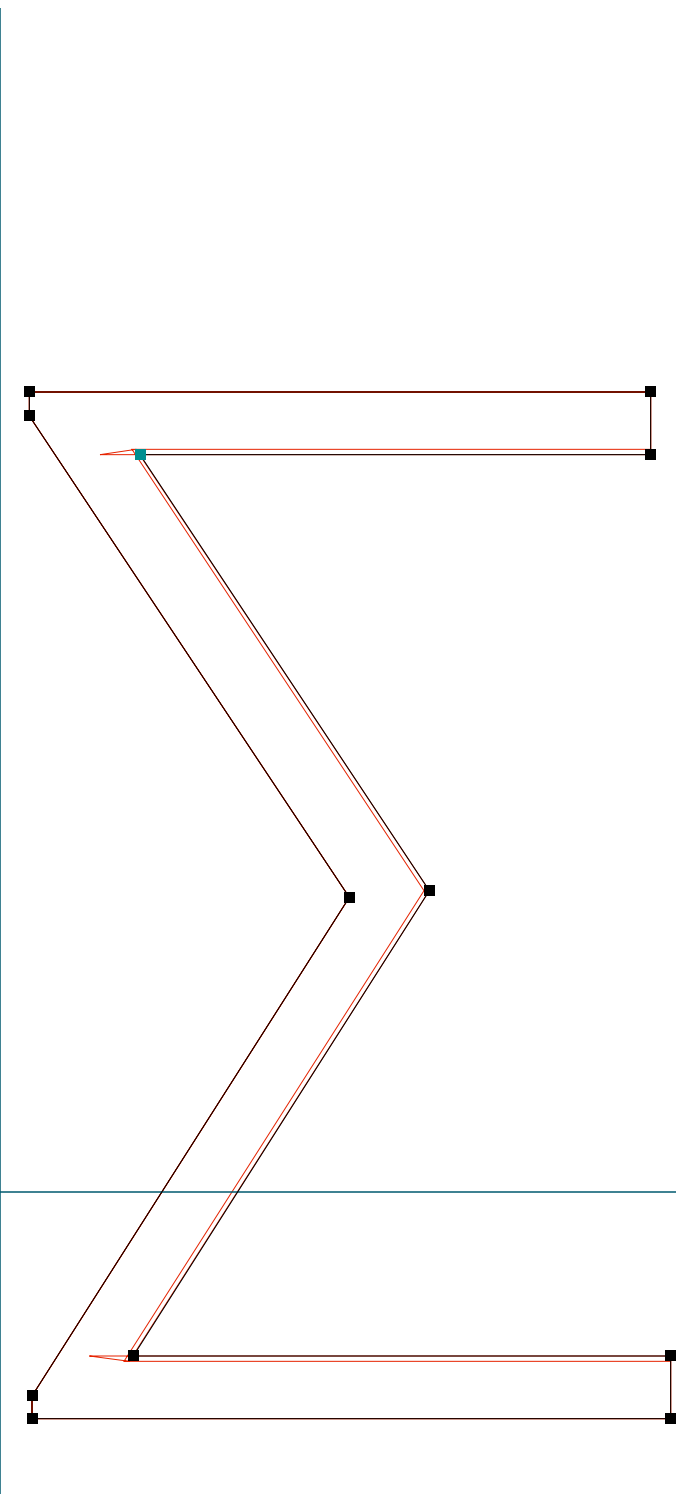

MR EAVES SANS & MODERN

MrEavesSan Bk | Delta | RoboFog Sketches | 2009 | Emigre Fonts

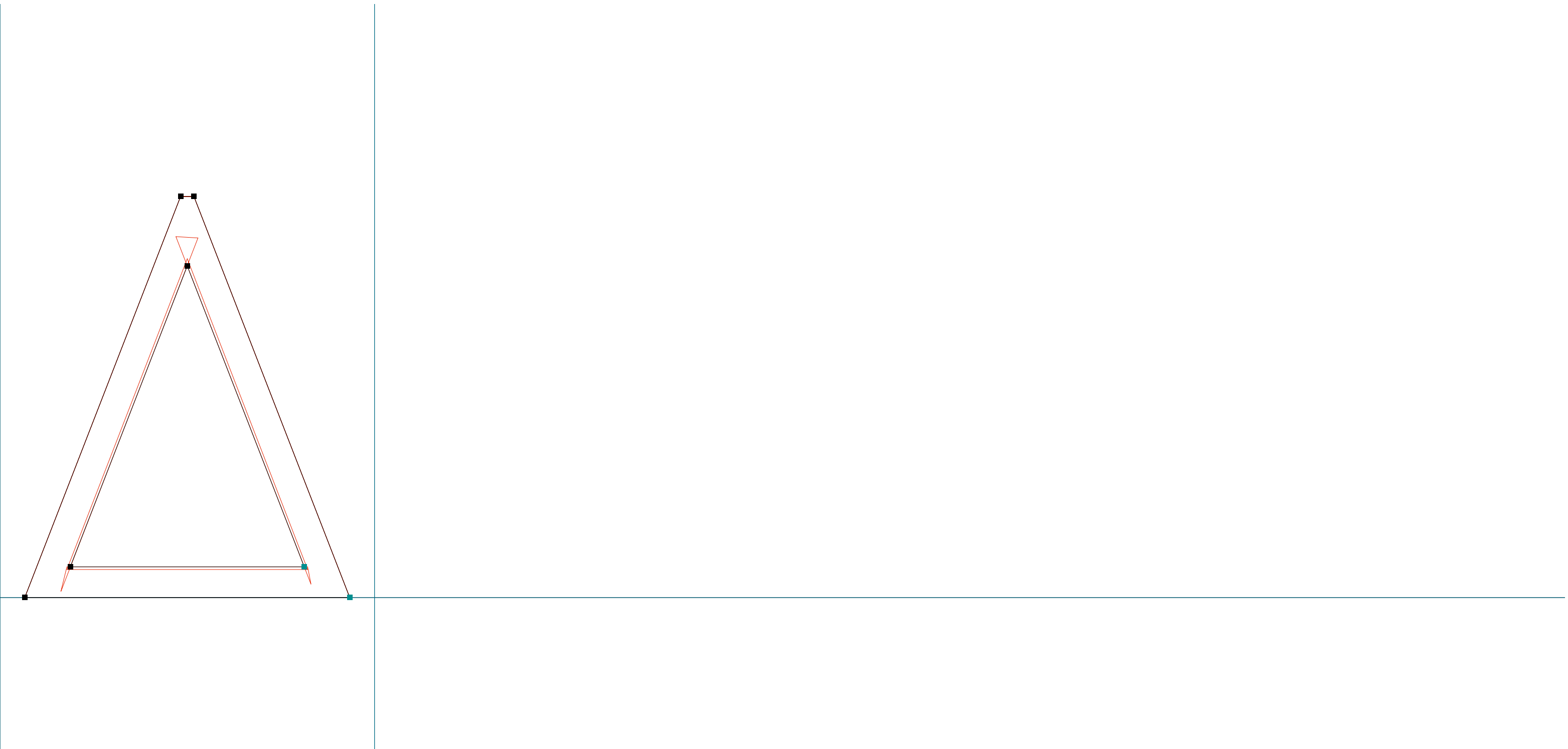

MR EAVES SANS & MODERN

MrEavesSan Bk | fl | RoboFog Sketches | 2009 | Emigre Fonts

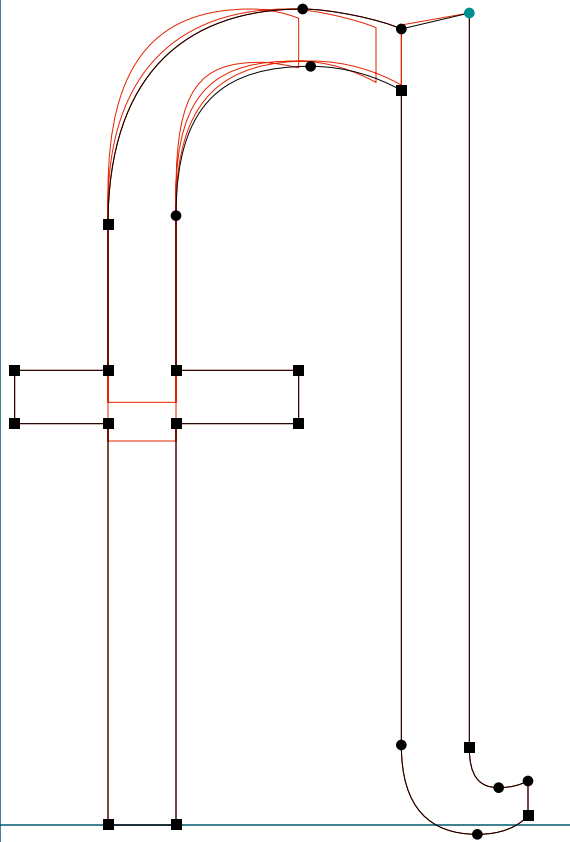
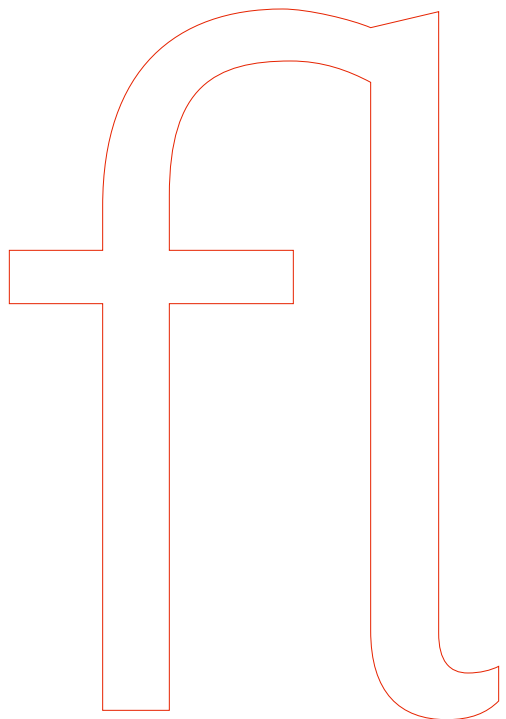

MR EAVES SANS & MODERN

MrEavesSan Bk | apple | RoboFog Sketches | 2009 | Emigre Fonts

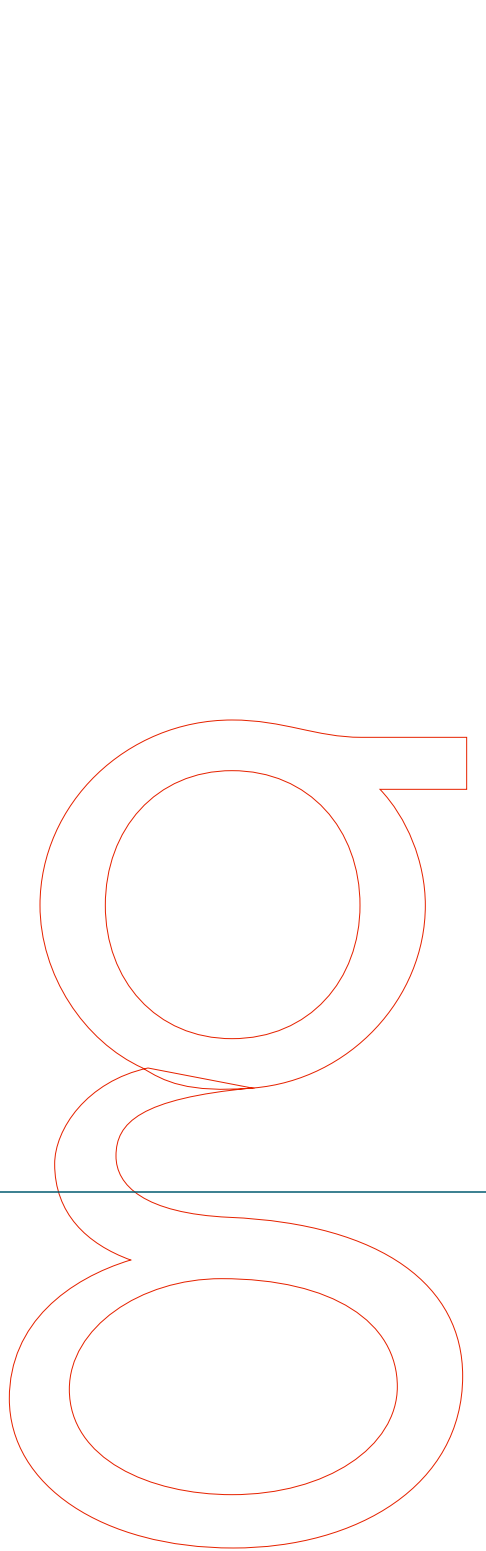
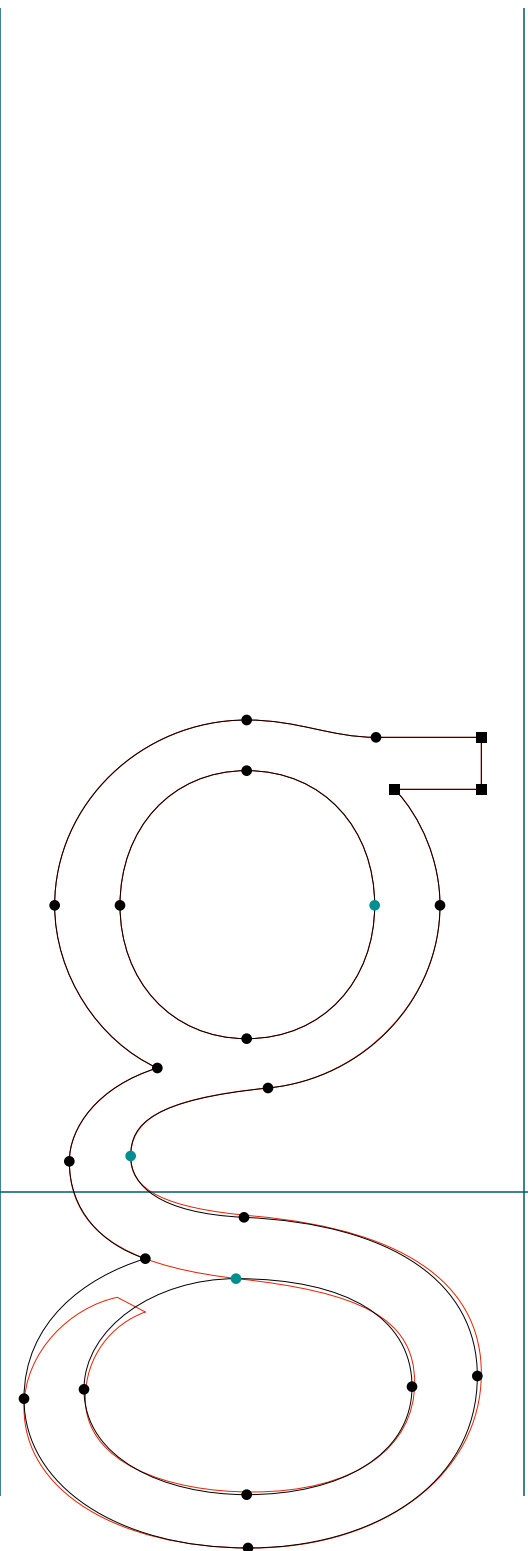

MR EAVES SANS & MODERN

MrEavesSanAlt Bk | Q | RoboFog Sketches | 2009 | Emigre Fonts

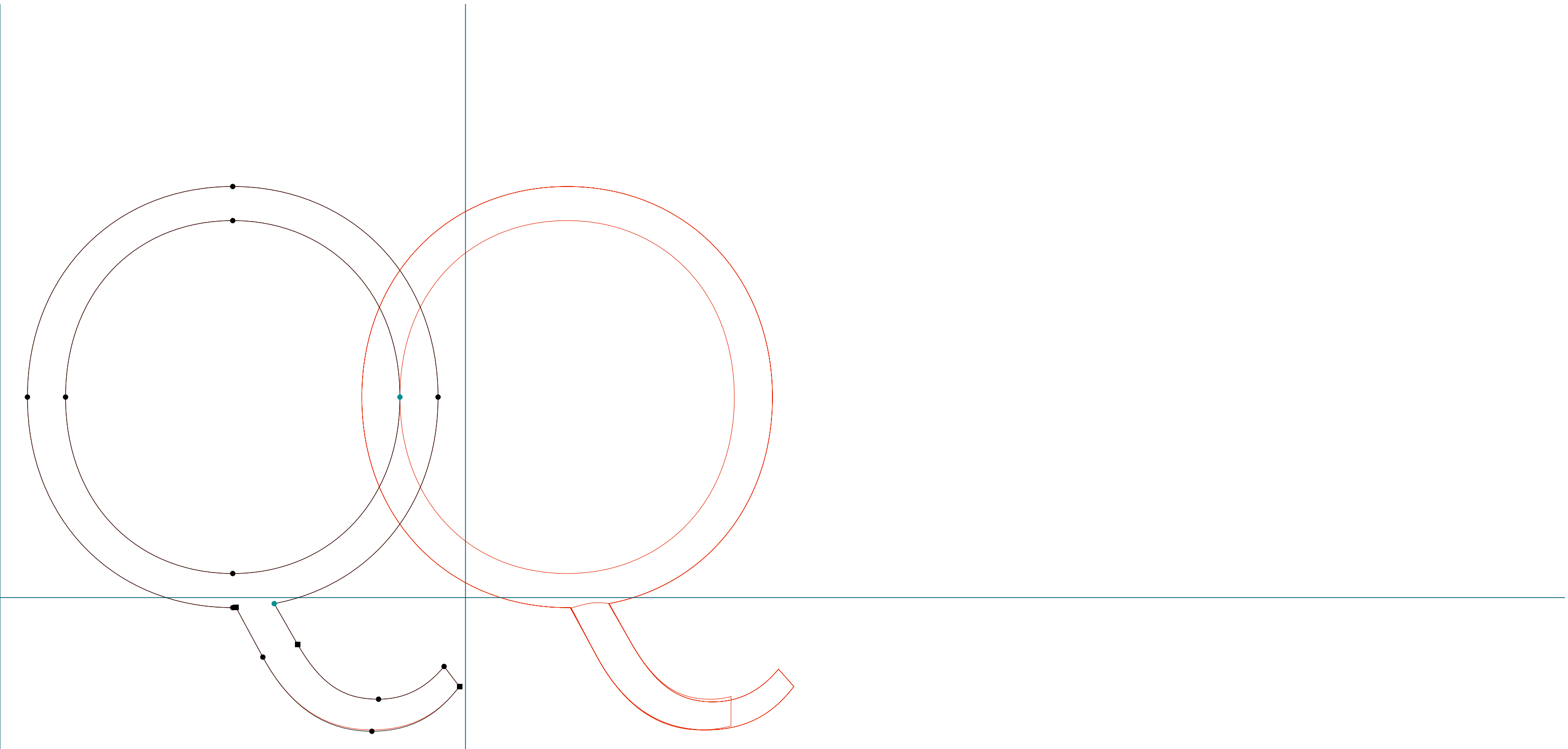

MR EAVES SANS & MODERN

MrEavesSan BkI | x | RoboFog Sketches | 2009 | Emigre Fonts

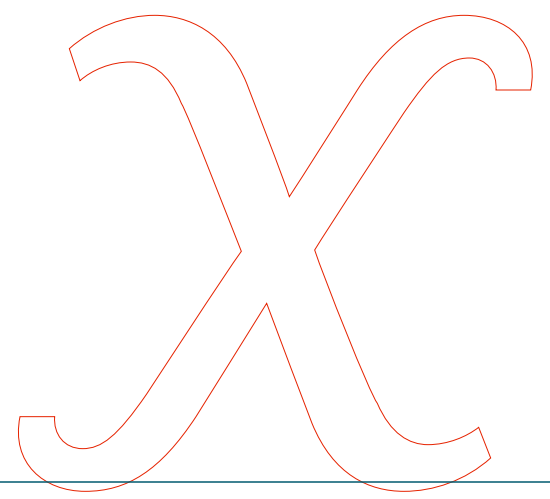
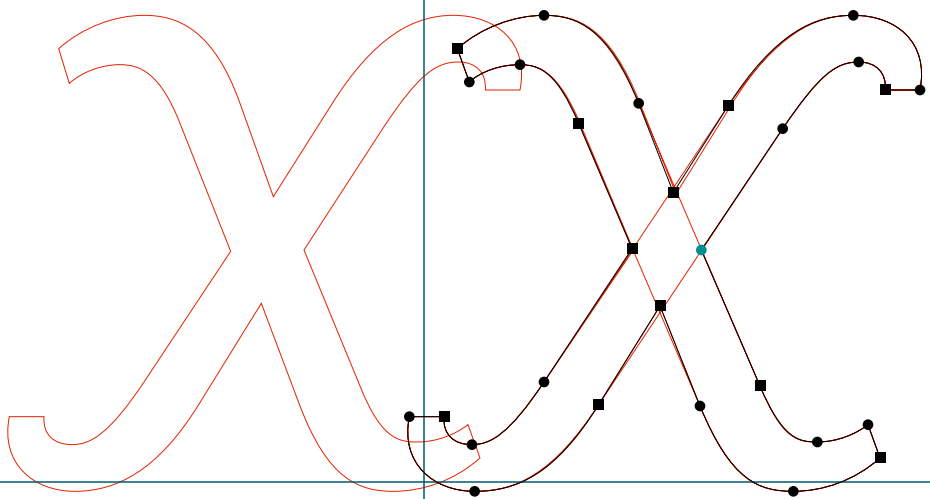

MR EAVES SANS & MODERN

MrEavesSan BkI | apple | RoboFog Sketches | 2009 | Emigre Fonts

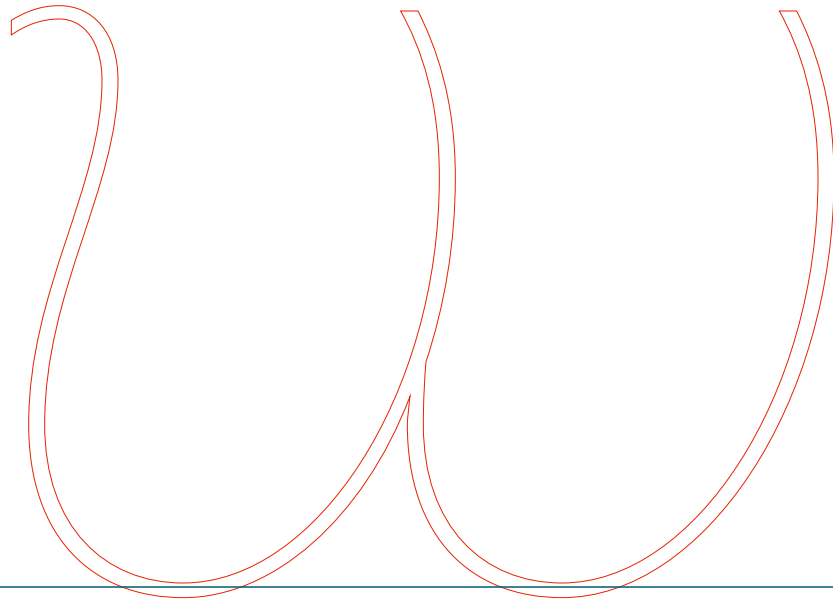

MR EAVES SANS & MODERN

MrEavesSanAlt BkI | apple | RoboFog Sketches | 2009 | Emigre Fonts

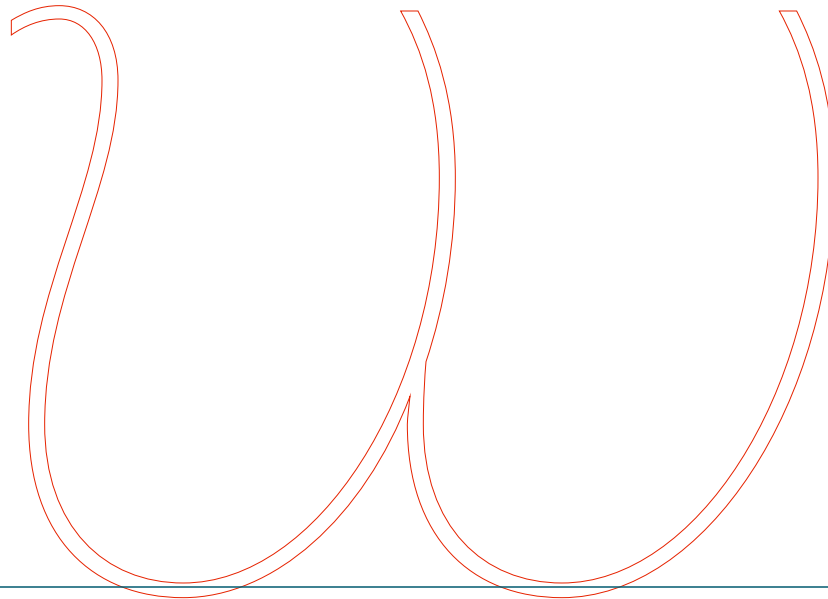

MR EAVES SANS & MODERN

MrEavesSan H | DC2 | RoboFog Sketches | 2009 | Emigre Fonts

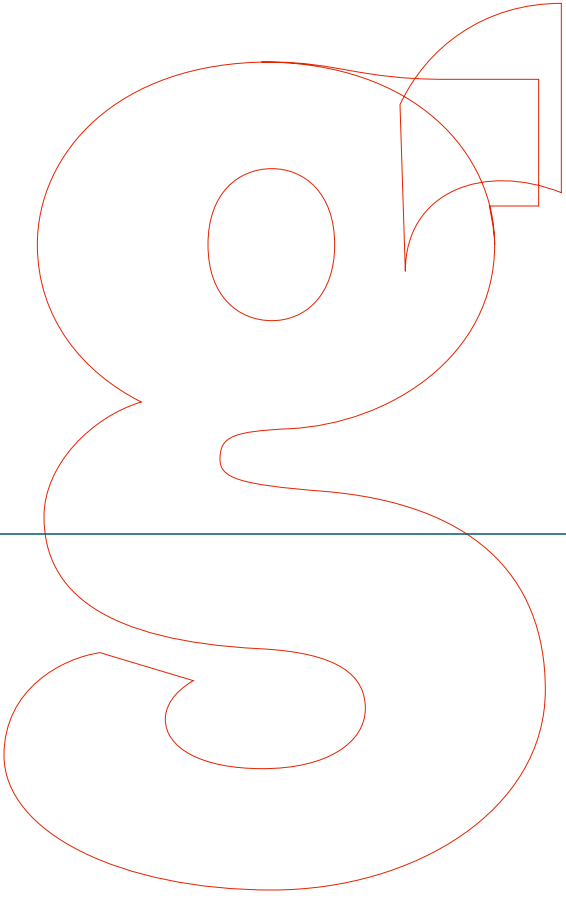
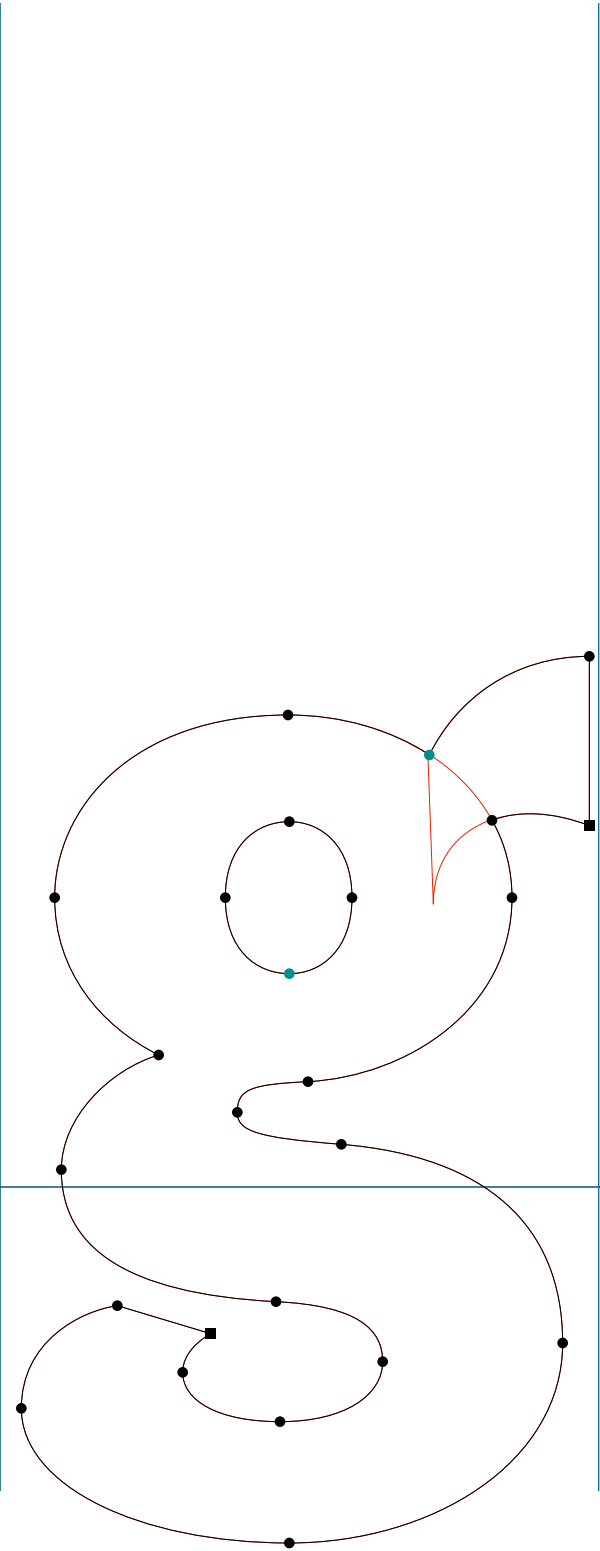

MR EAVES SANS & MODERN

MrEavesSan H | x | RoboFog Sketches | 2009 | Emigre Fonts

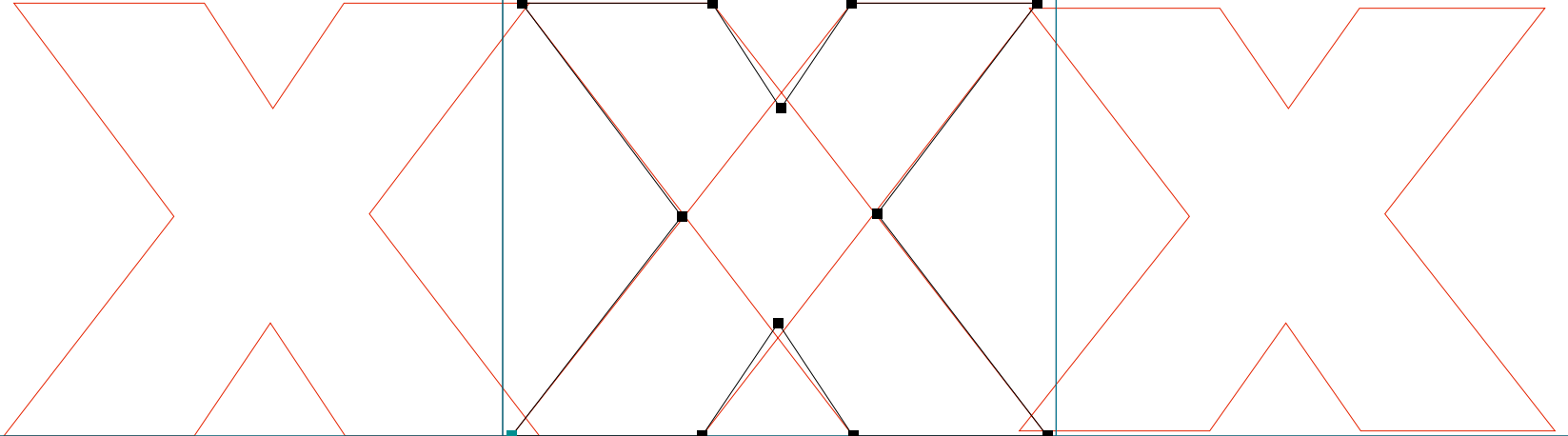

MR EAVES SANS & MODERN

MrEavesSan H | apple | RoboFog Sketches | 2009 | Emigre Fonts

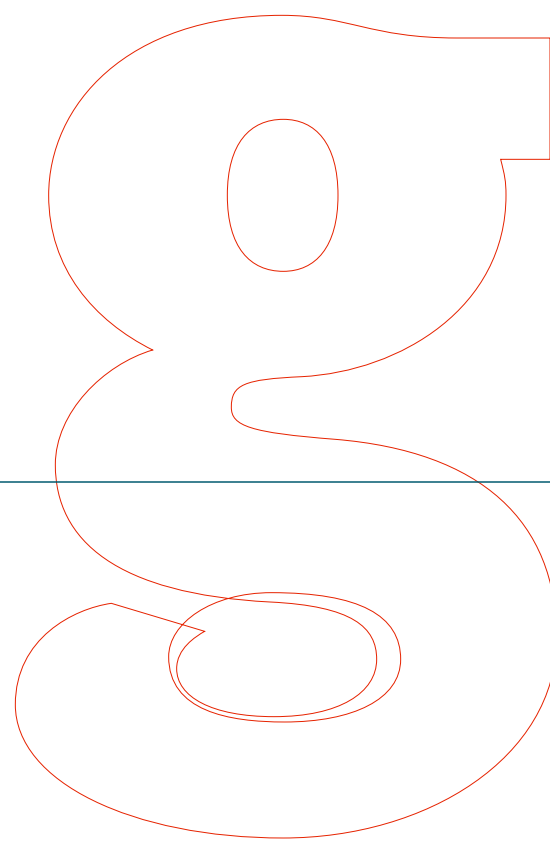
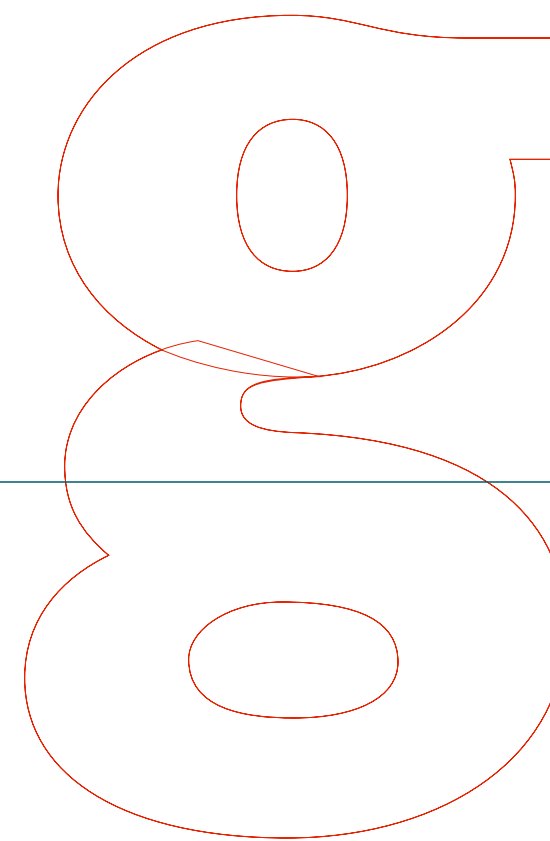
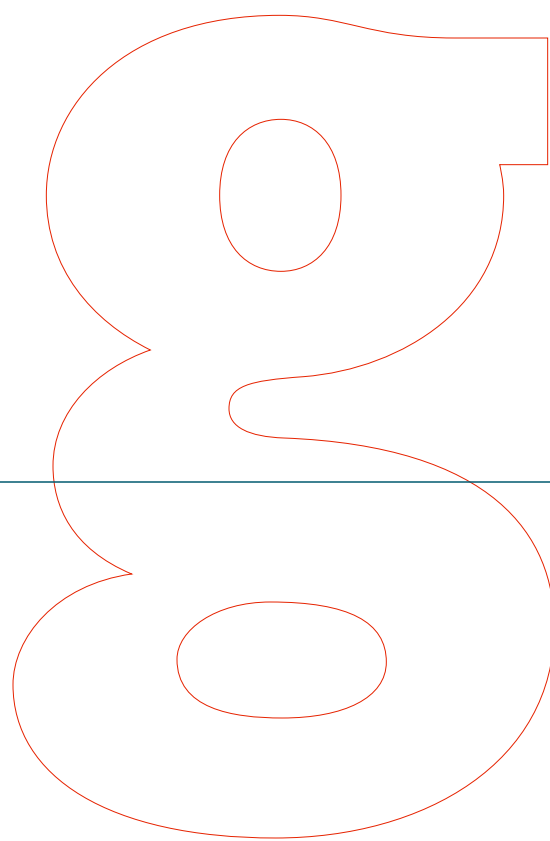
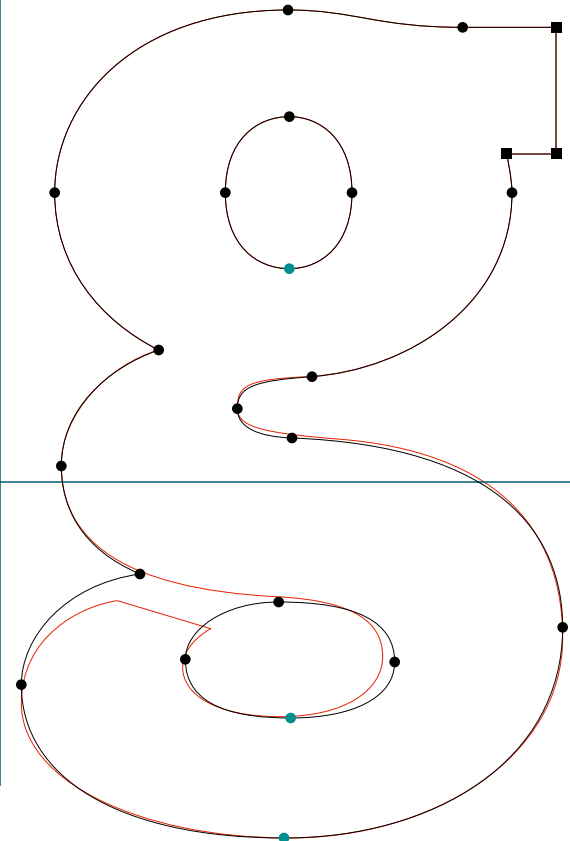
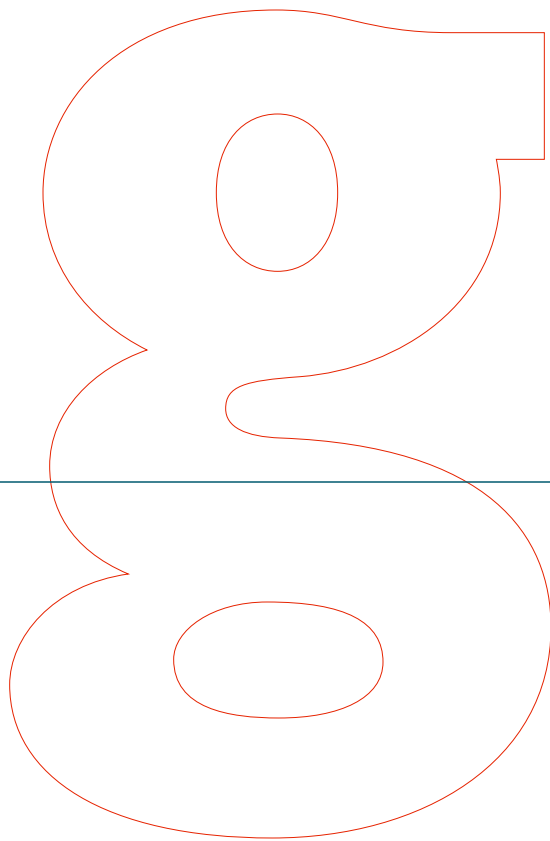

MR EAVES SANS & MODERN

MrEavesSan HI | z | RoboFog Sketches | 2009 | Emigre Fonts

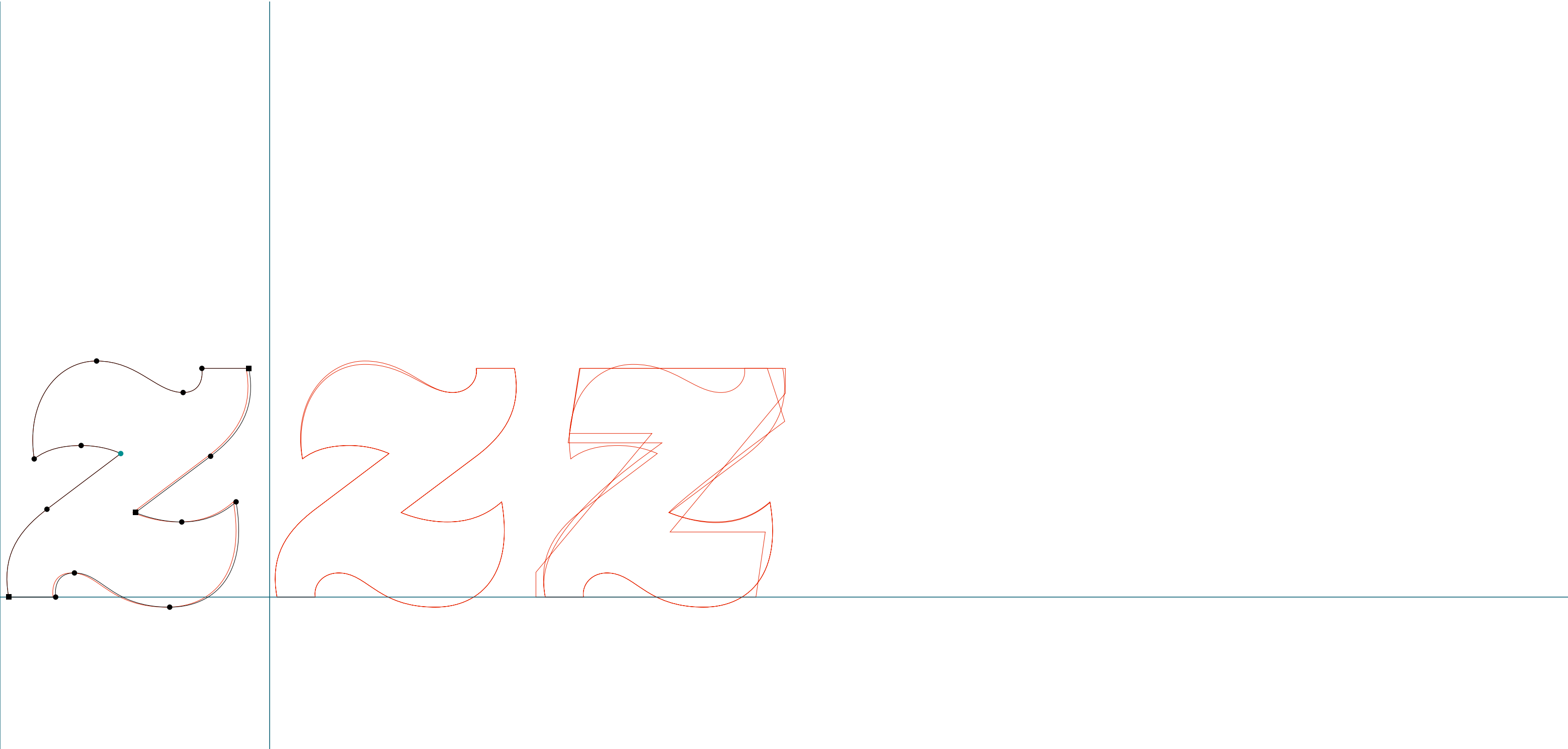

MR EAVES SANS & MODERN

MrEavesMod TI | a | RoboFog Sketches | 2009 | Emigre Fonts

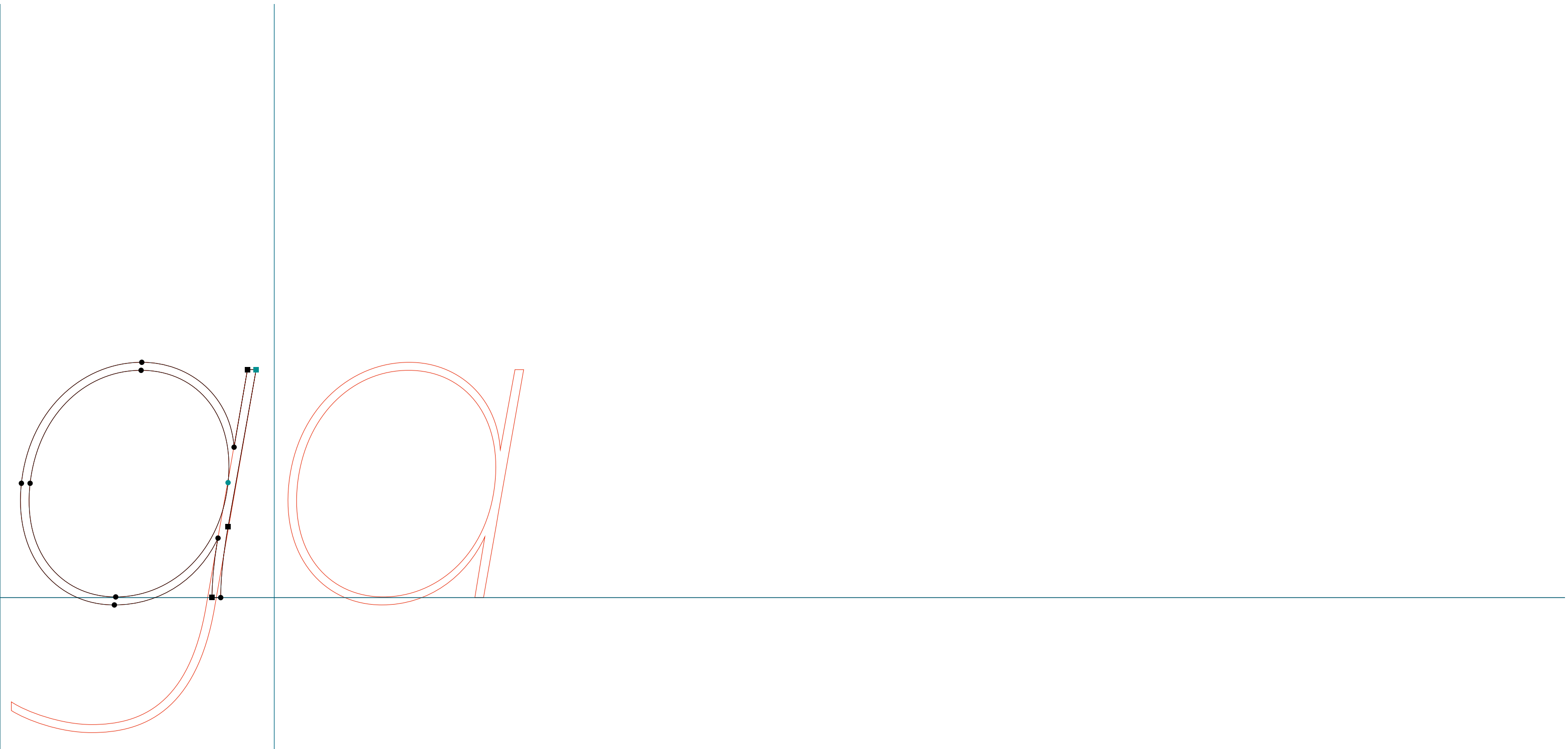

MR EAVES SANS & MODERN

MrEavesMod TI | g | RoboFog Sketches | 2009 | Emigre Fonts



MR EAVES SANS & MODERN

MrEavesMod TI | j | RoboFog Sketches | 2009 | Emigre Fonts

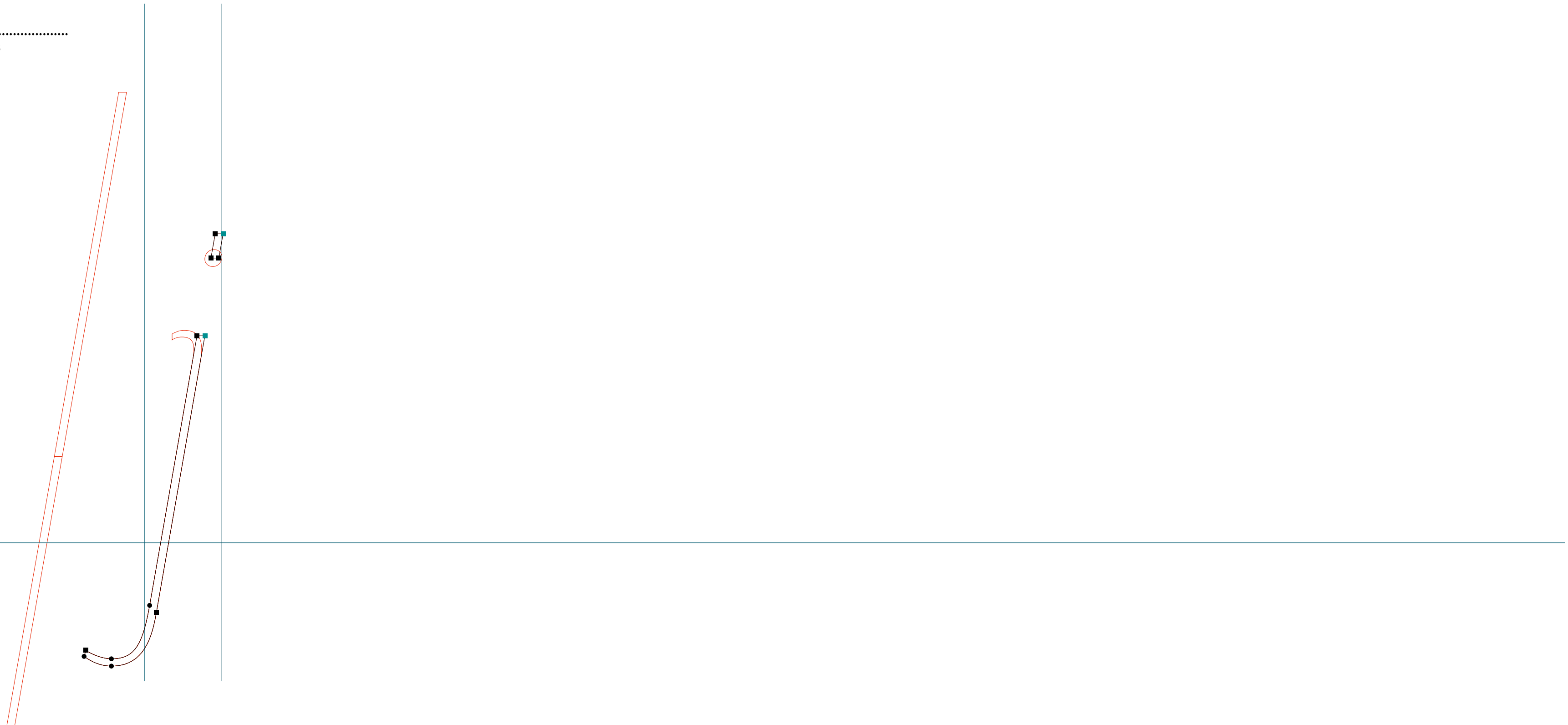

MR EAVES SANS & MODERN

MrEavesMod TI | m | RoboFog Sketches | 2009 | Emigre Fonts

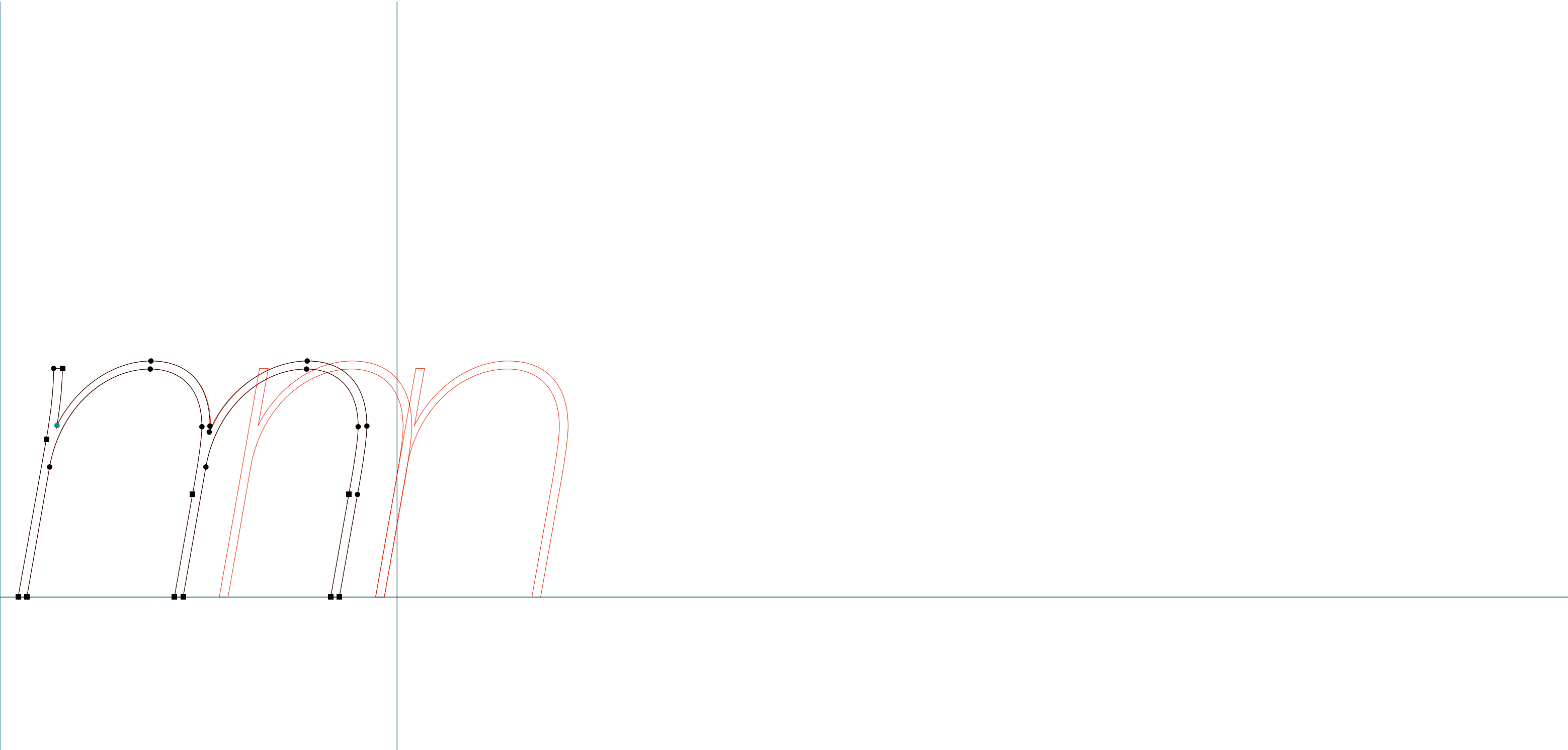

MR EAVES SANS & MODERN

MrEavesMod TI | n | RoboFog Sketches | 2009 | Emigre Fonts

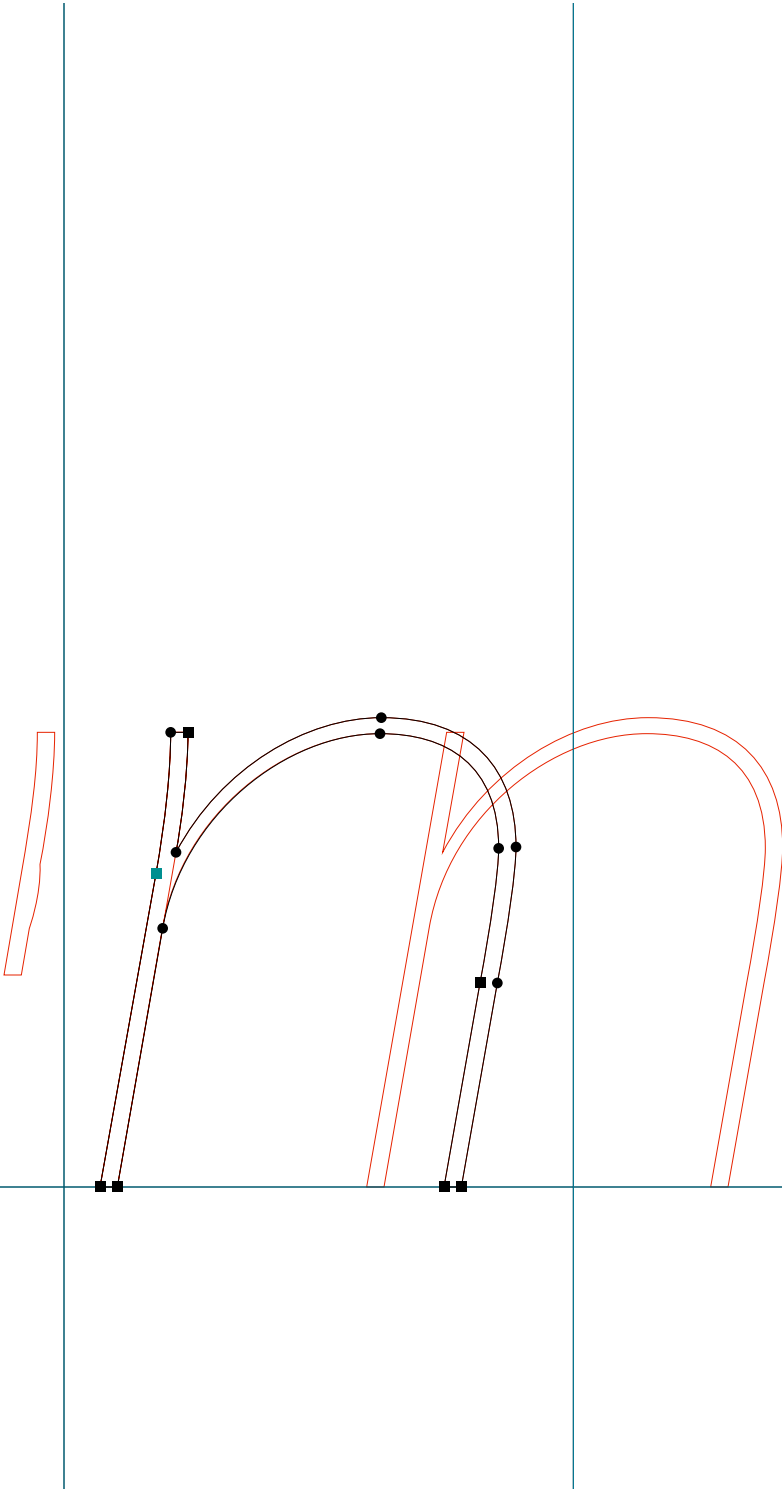

MR EAVES SANS & MODERN

MrEavesMod TI | r | RoboFog Sketches | 2009 | Emigre Fonts

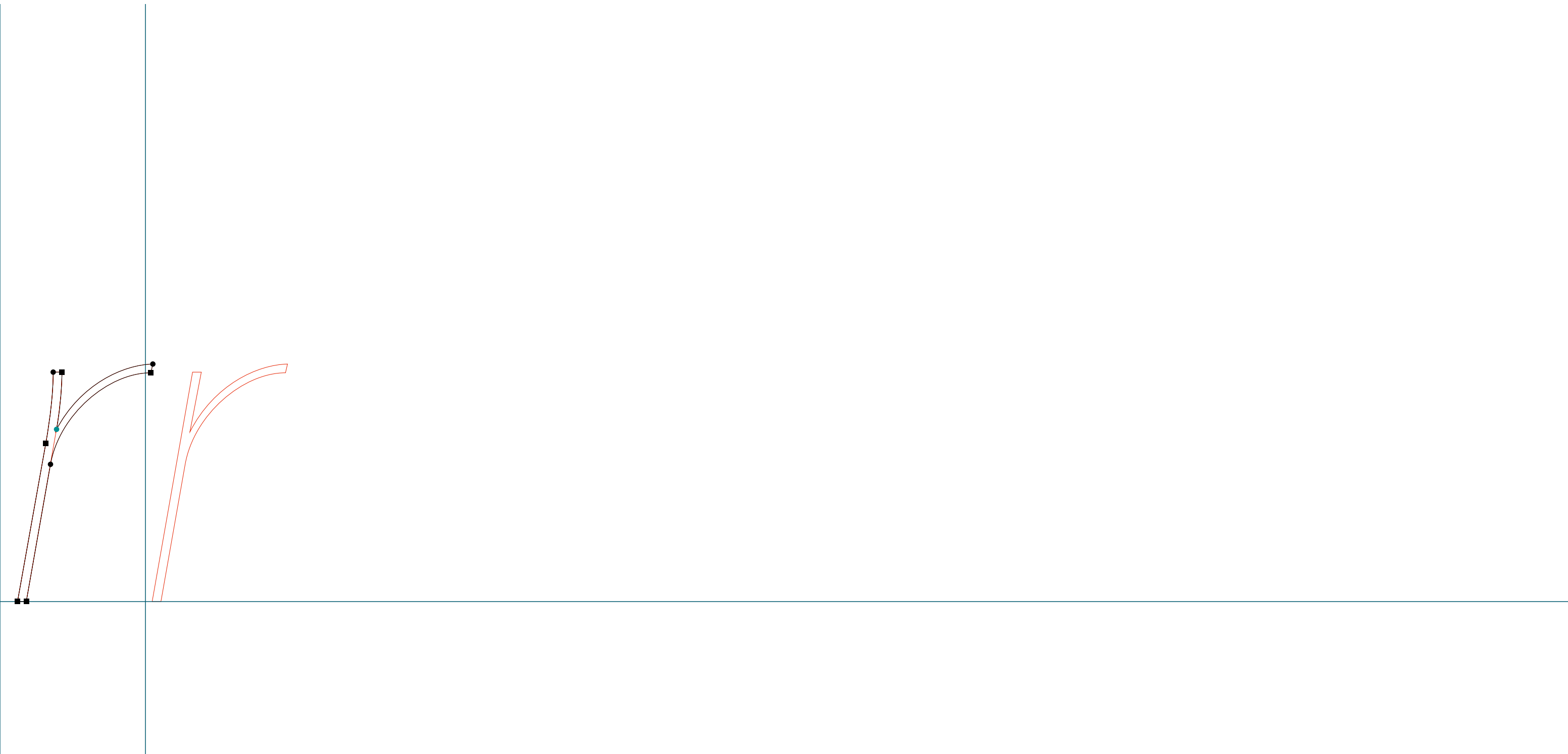

MR EAVES SANS & MODERN

MrEavesMod RI | R | RoboFog Sketches | 2009 | Emigre Fonts



MR EAVES SANS & MODERN

MrEavesMod RI | dotlessi | RoboFog Sketches | 2009 | Emigre Fonts

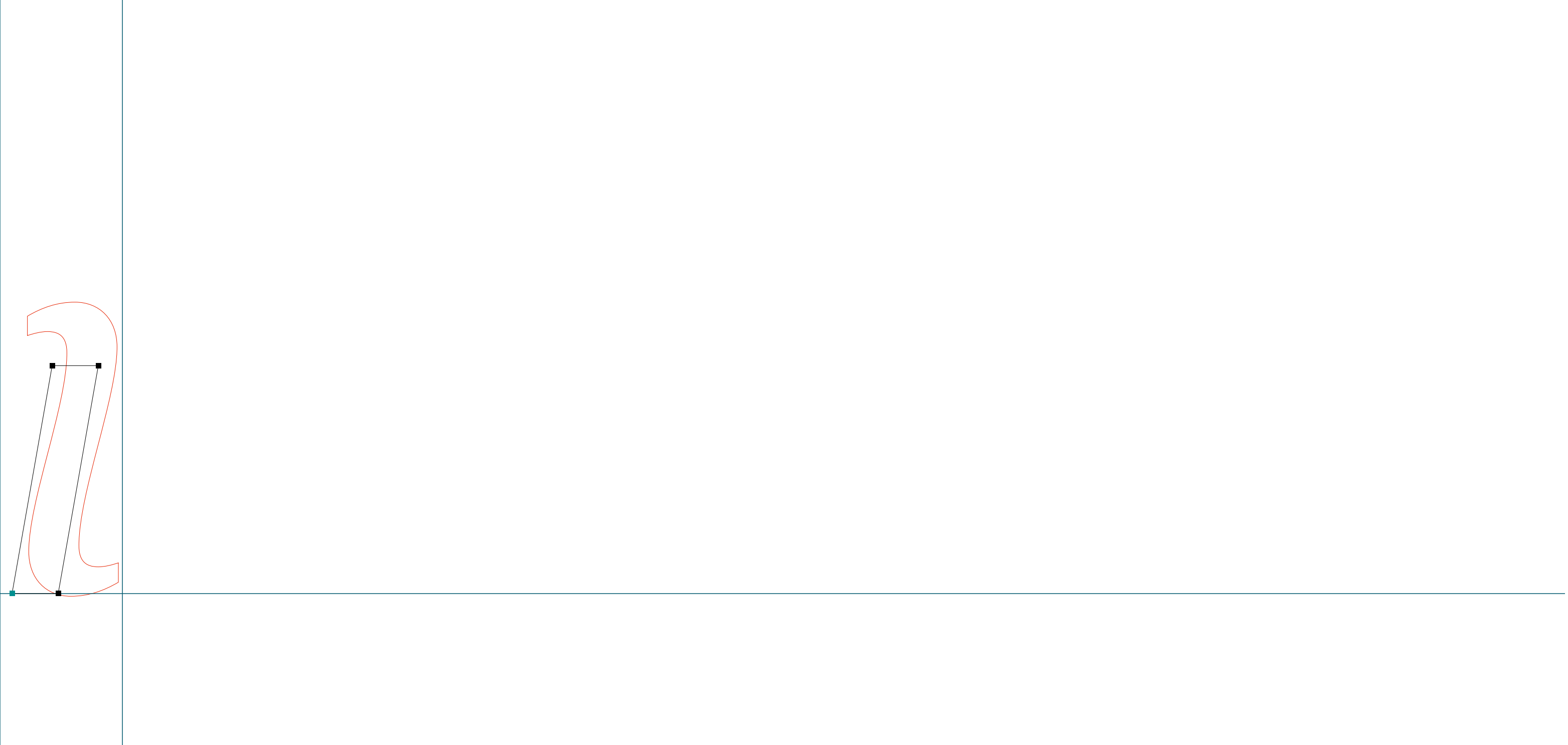

MR EAVES SANS & MODERN

MrEavesModAlt RI | R | RoboFog Sketches | 2009 | Emigre Fonts

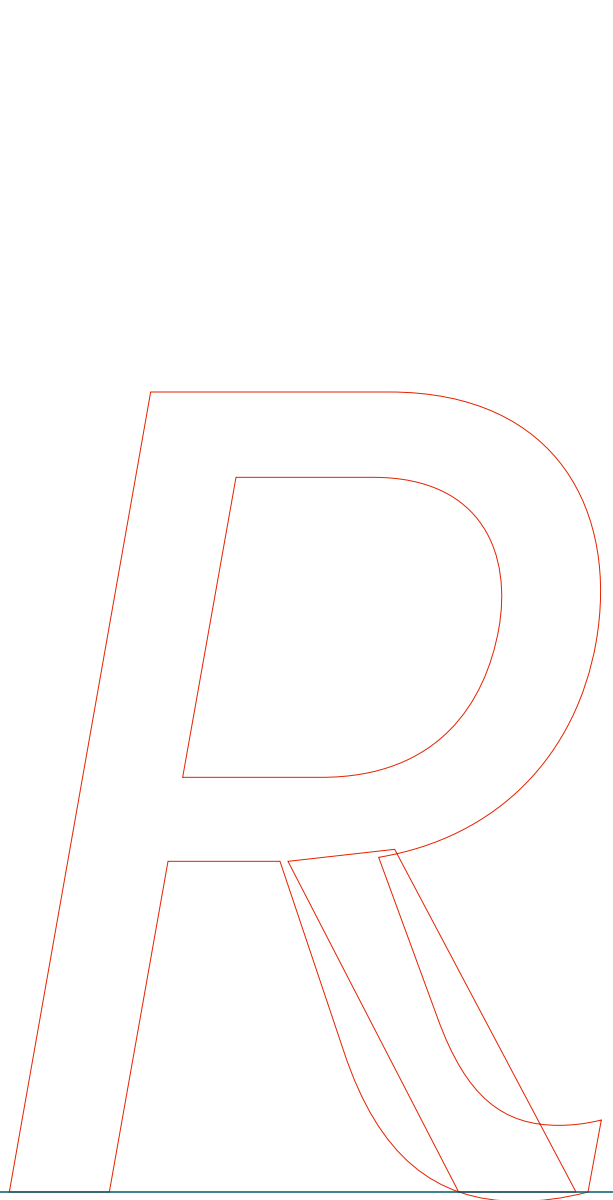
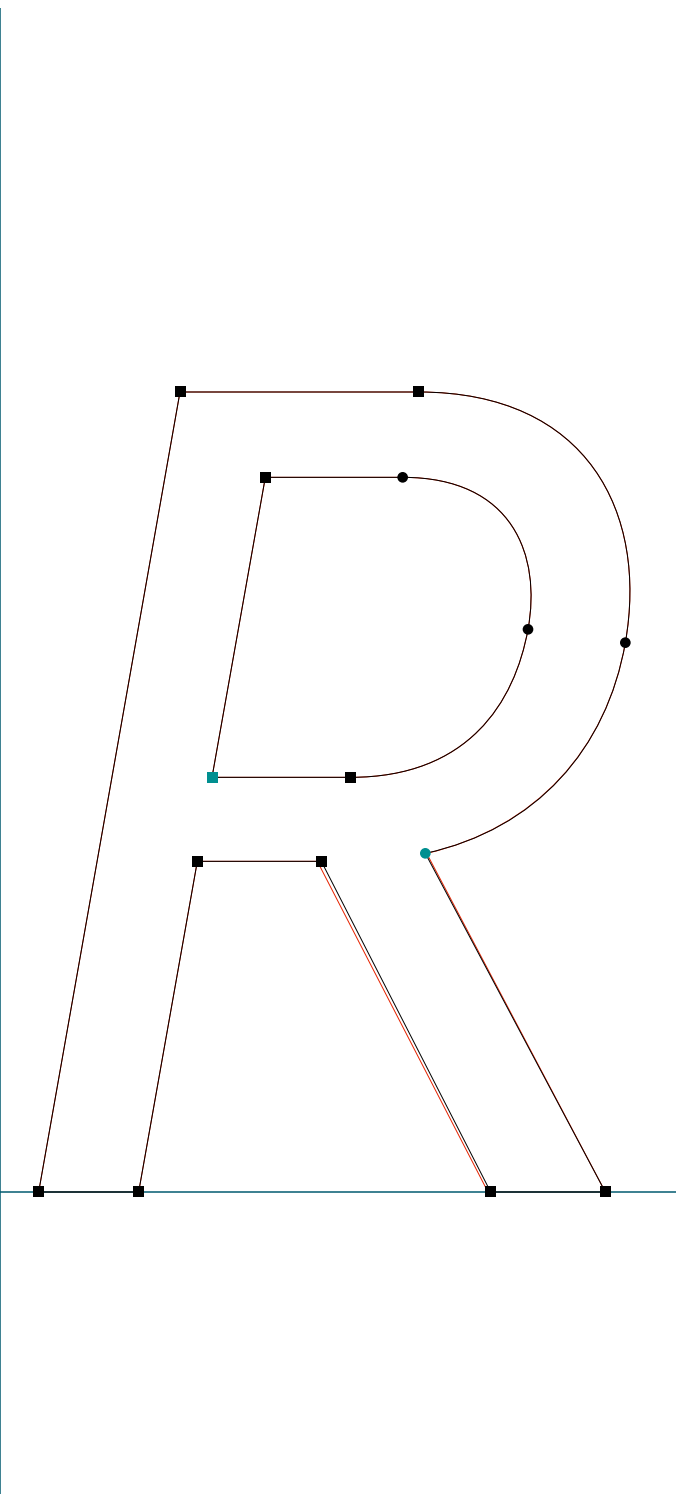

MR EAVES SANS & MODERN

MrEavesModAlt RI | apple | RoboFog Sketches | 2009 | Emigre Fonts

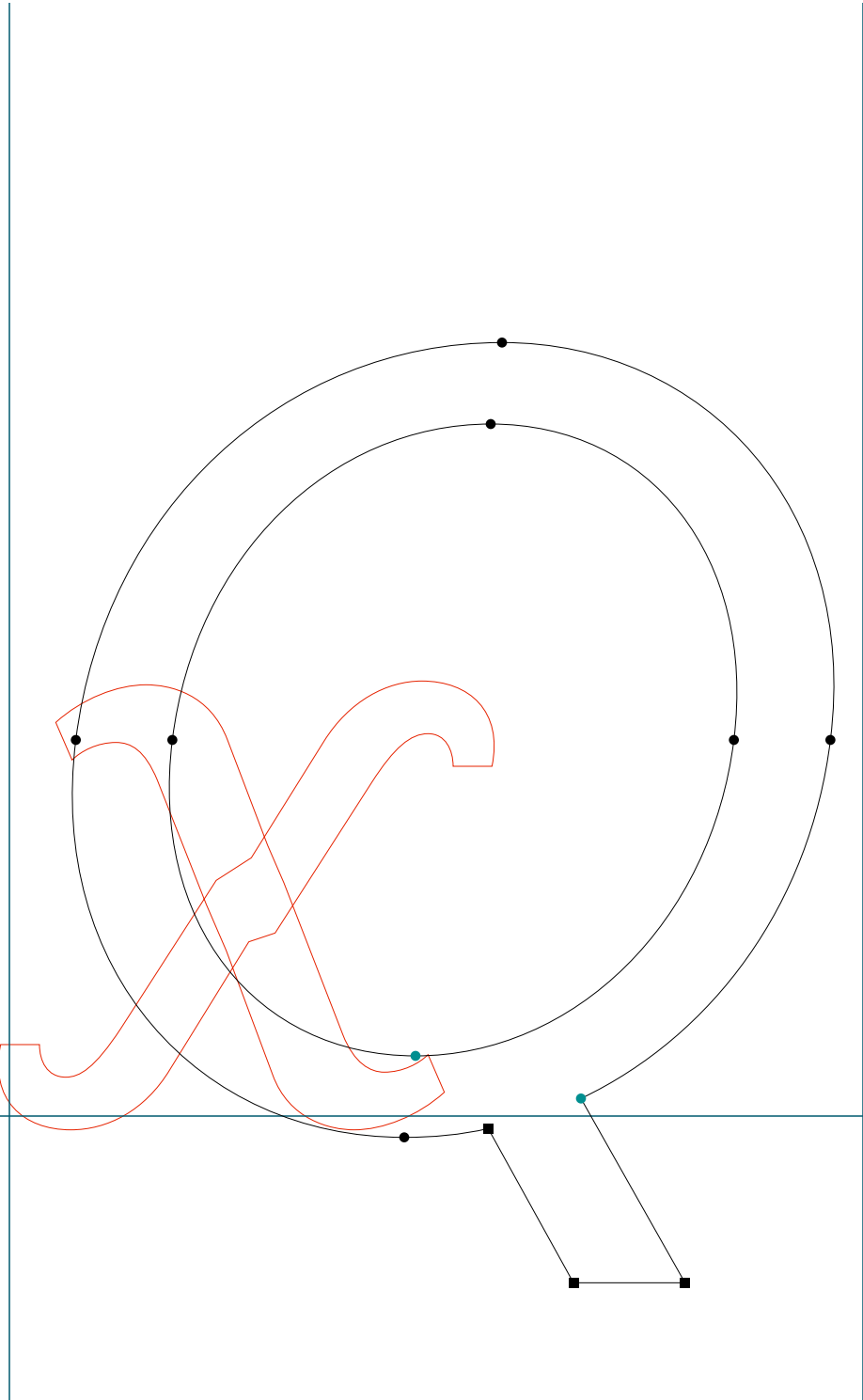

MR EAVES SANS & MODERN

MrEavesModAlt RI | dotlessi | RoboFog Sketches | 2009 | Emigre Fonts

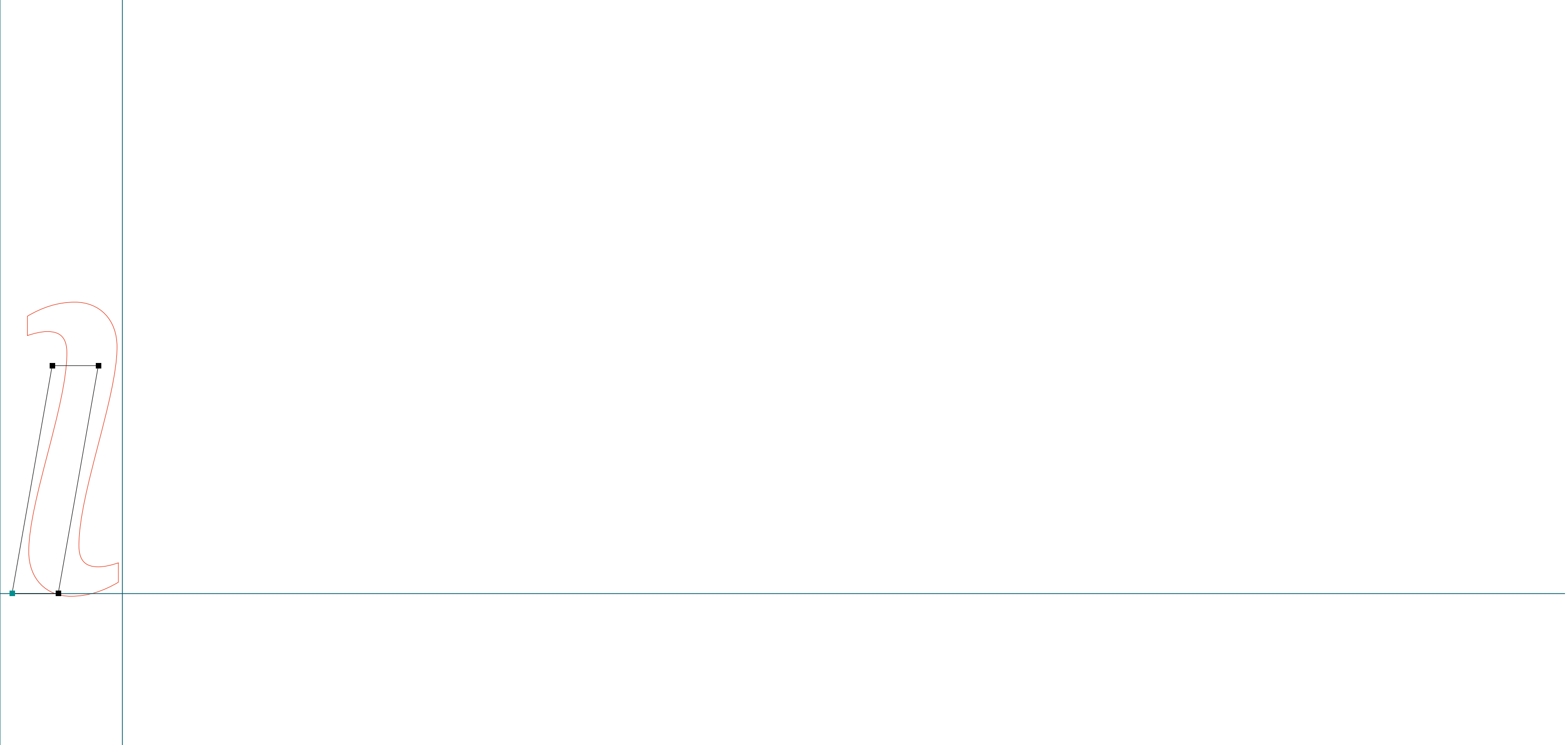

MR EAVES SANS & MODERN

MrEavesMod Bk | comma | RoboFog Sketches | 2009 | Emigre Fonts

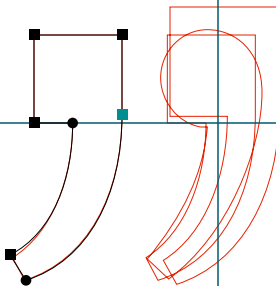

MR EAVES SANS & MODERN

MrEavesMod Bk | grave | RoboFog Sketches | 2009 | Emigre Fonts

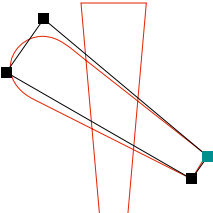

MR EAVES SANS & MODERN

MrEavesModAlt Bk | grave | RoboFog Sketches | 2009 | Emigre Fonts

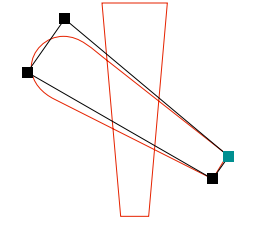

MR EAVES SANS & MODERN

MrEavesMod BkI | n | RoboFog Sketches | 2009 | Emigre Fonts

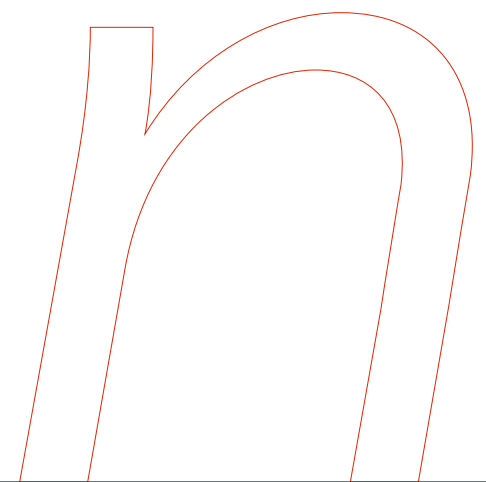
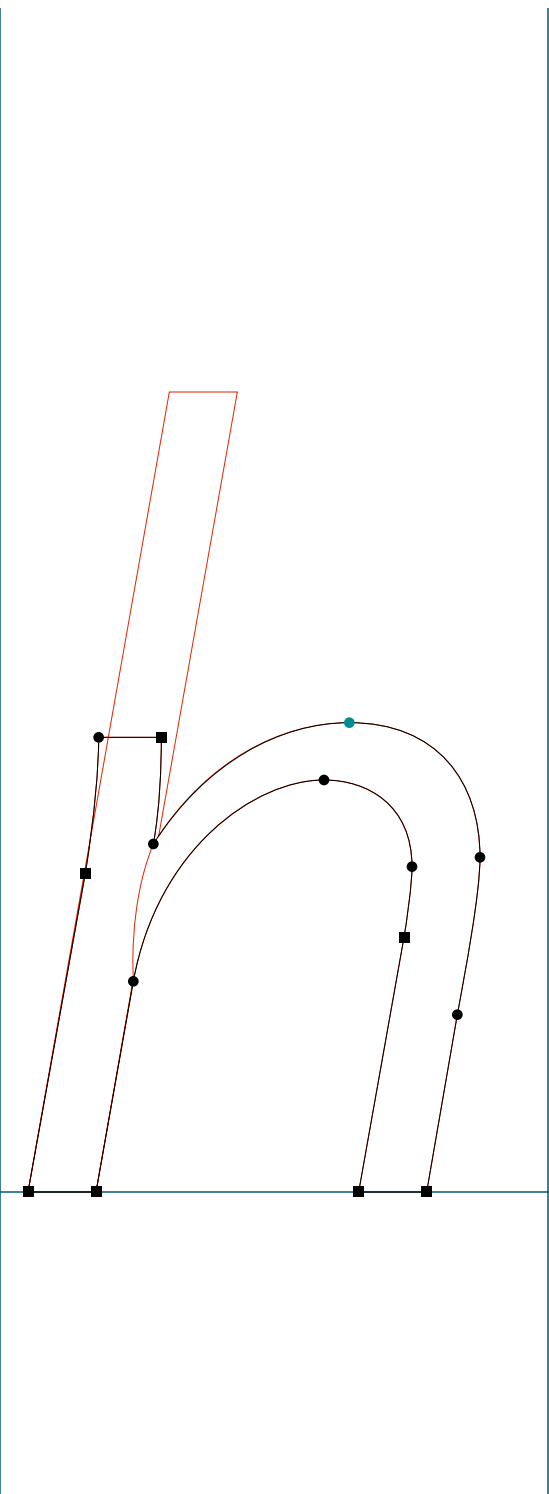

MR EAVES SANS & MODERN

MrEavesMod H | Q | RoboFog Sketches | 2009 | Emigre Fonts

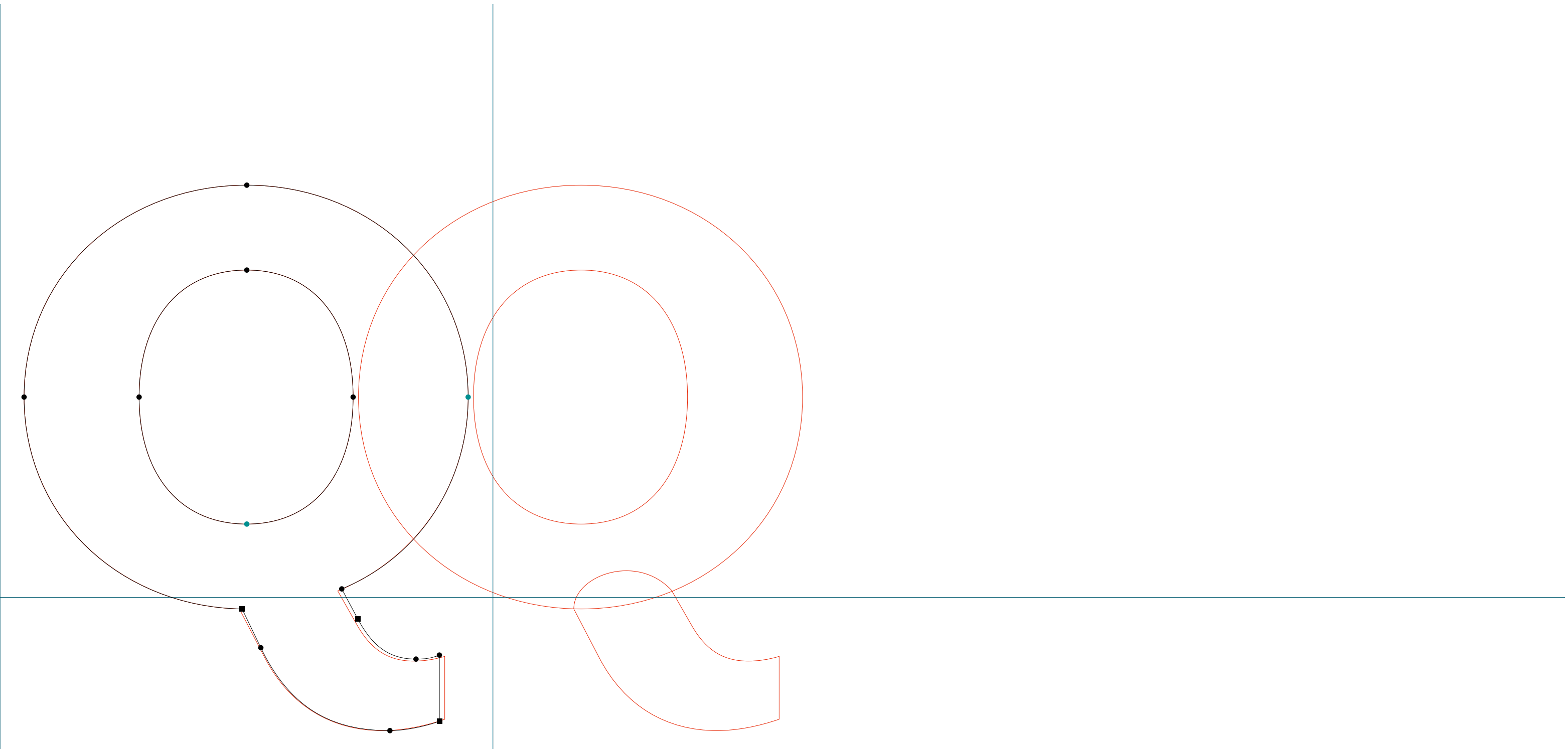

MR EAVES SANS & MODERN

.....
MrsEavesXLSan RSAVE | RS | RoboFog Sketches | 2009 | Emigre Fonts

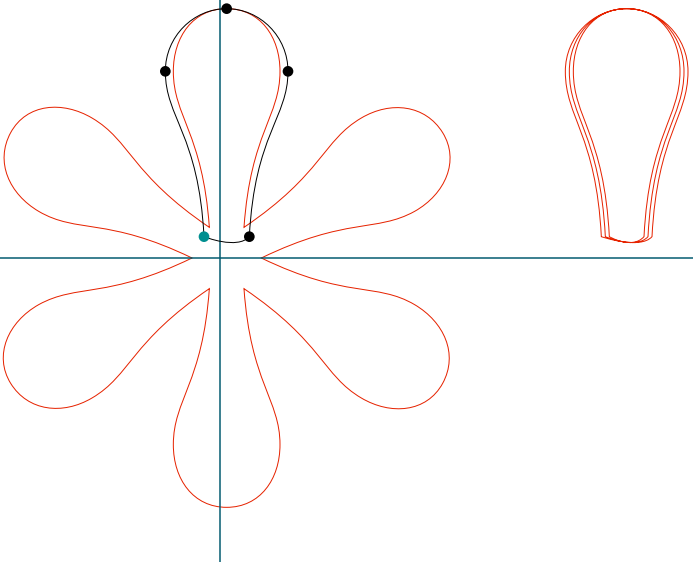

MR EAVES SANS & MODERN

.....
MrsEavesXLSan RSAVE | US | RoboFog Sketches | 2009 | Emigre Fonts

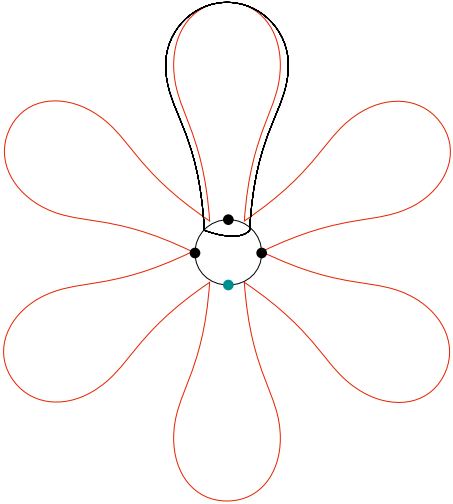

MR EAVES SANS & MODERN

.....
MrsEavesXLSan RSAVE | dollar | RoboFog Sketches | 2009 | Emigre Fonts

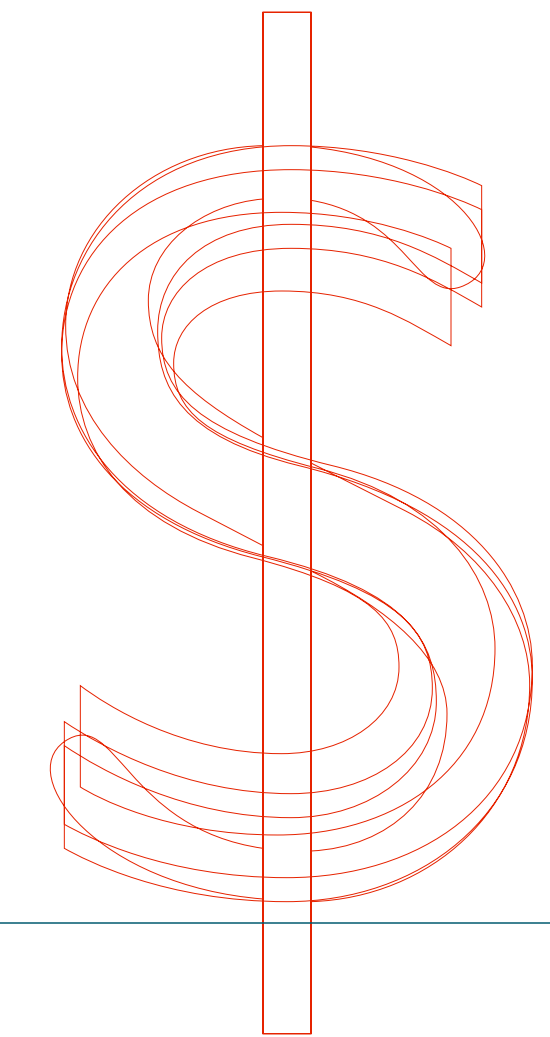
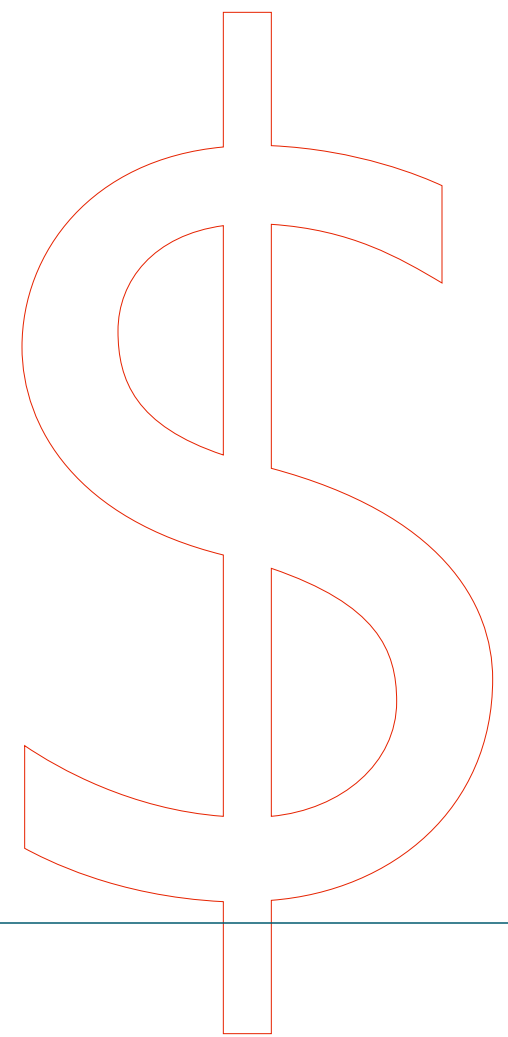
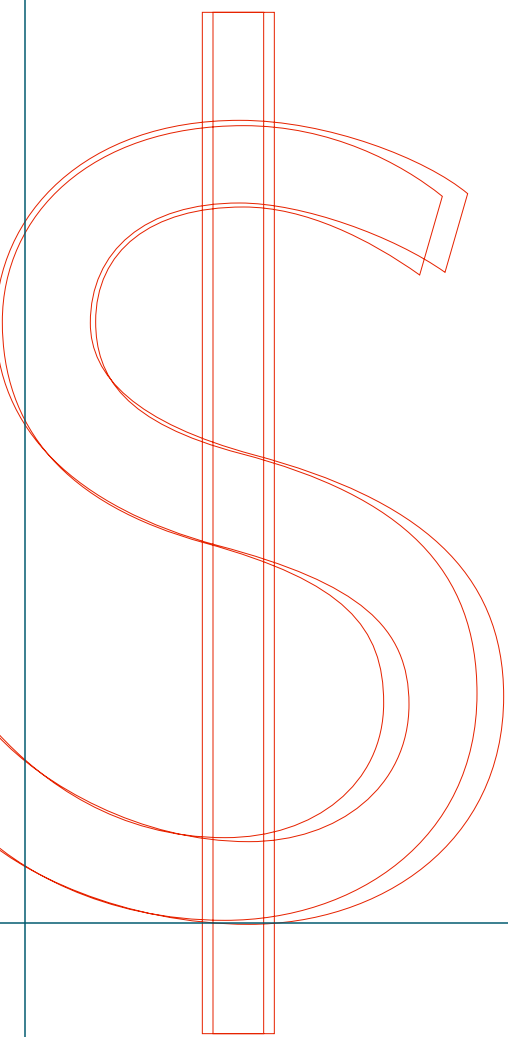
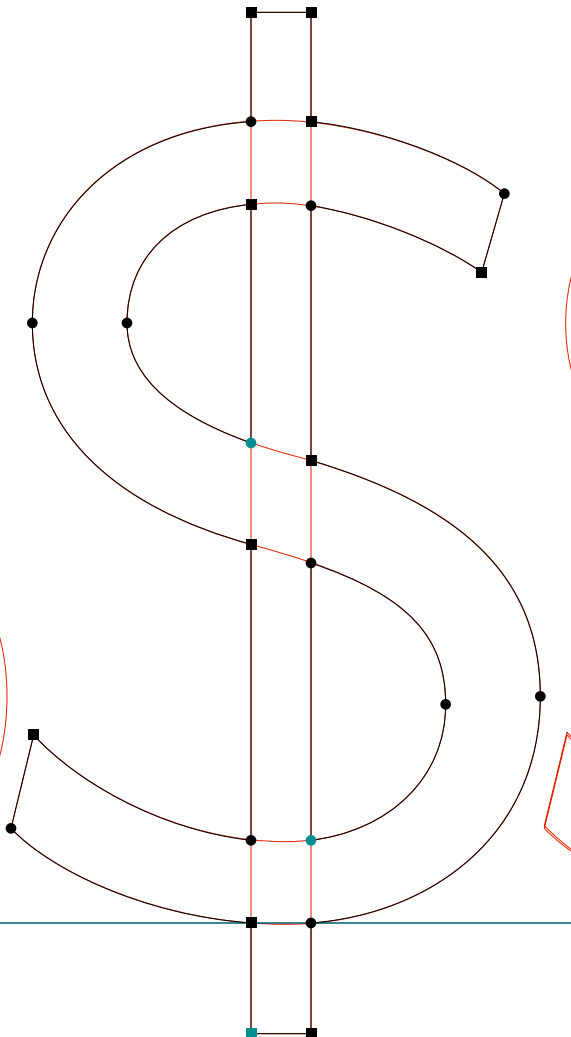
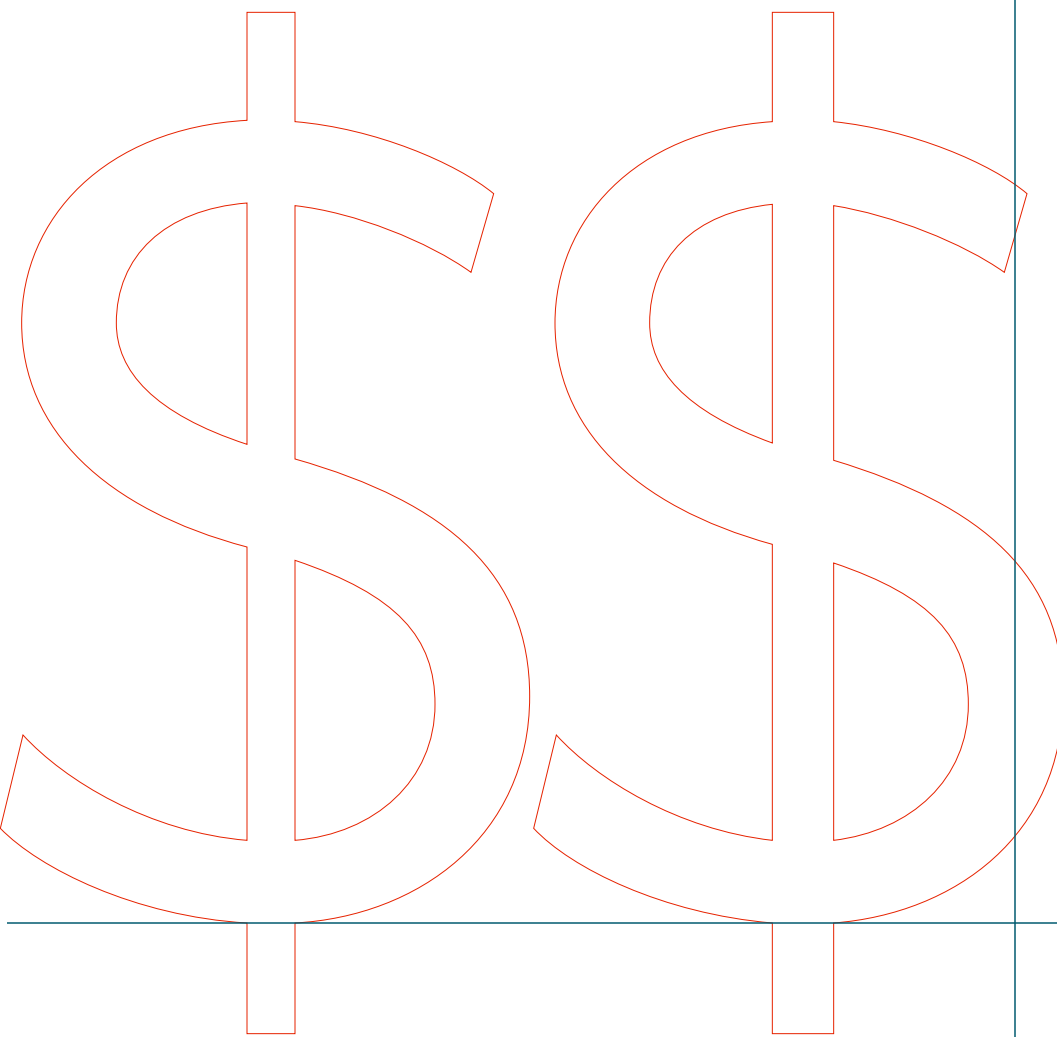

MR EAVES SANS & MODERN

.....
MrsEavesXLSan RSAVE | ampersand | RoboFog Sketches | 2009 | Emigre Fonts

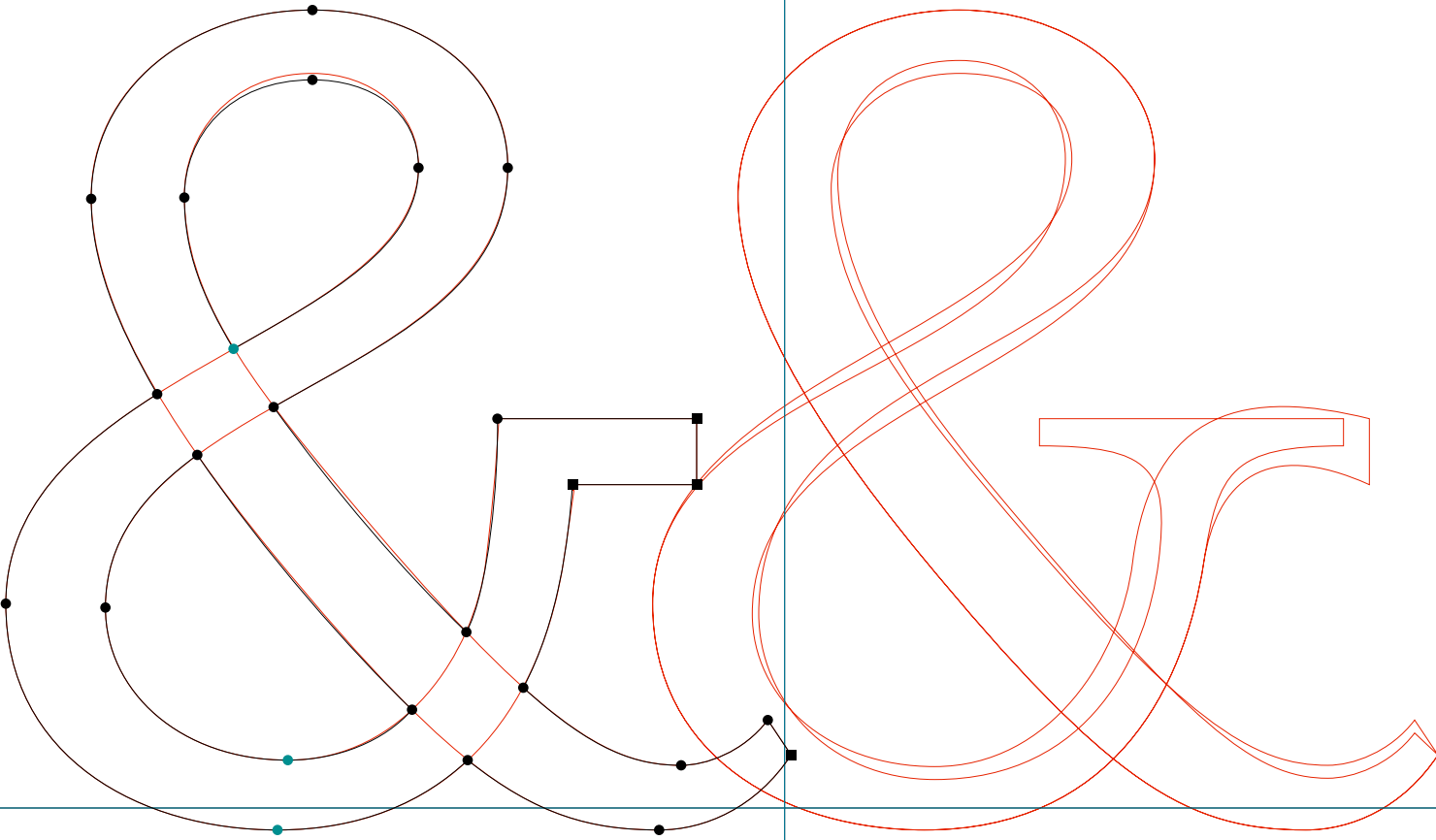

MR EAVES SANS & MODERN

.....
MrsEavesXLSan RSAVE | asterisk | RoboFog Sketches | 2009 | Emigre Fonts

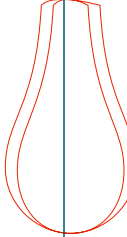
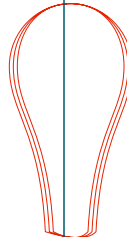
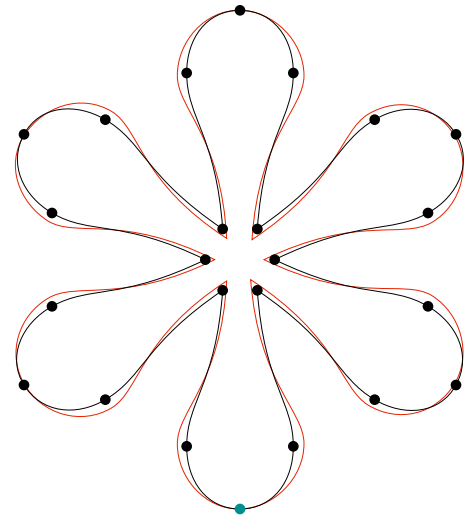

MR EAVES SANS & MODERN

.....
MrsEavesXLSan RSAVE | comma | RoboFog Sketches | 2009 | Emigre Fonts

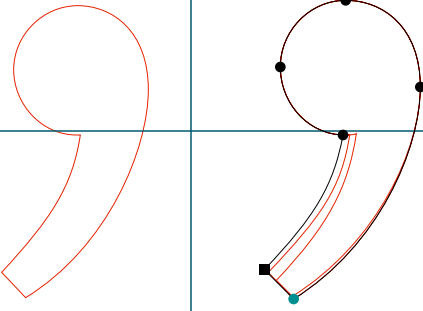

MR EAVES SANS & MODERN

.....
MrsEavesXLSan RSAVE | zero | RoboFog Sketches | 2009 | Emigre Fonts

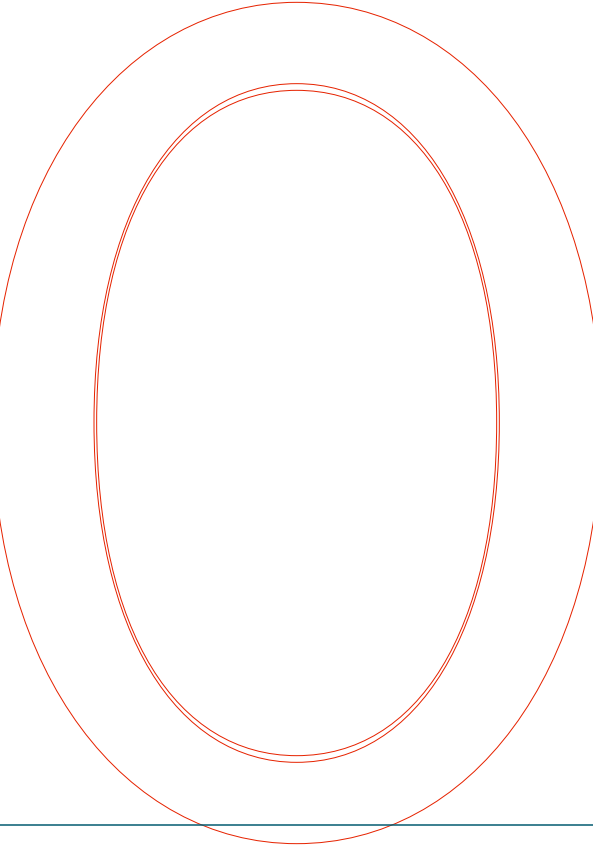
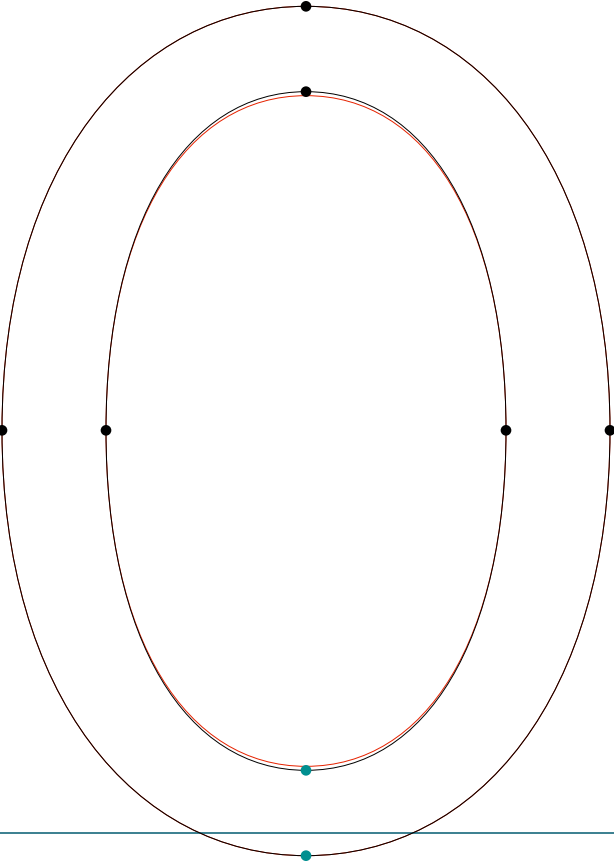

MR EAVES SANS & MODERN

.....
MrsEavesXLSan RSAVE | two | RoboFog Sketches | 2009 | Emigre Fonts

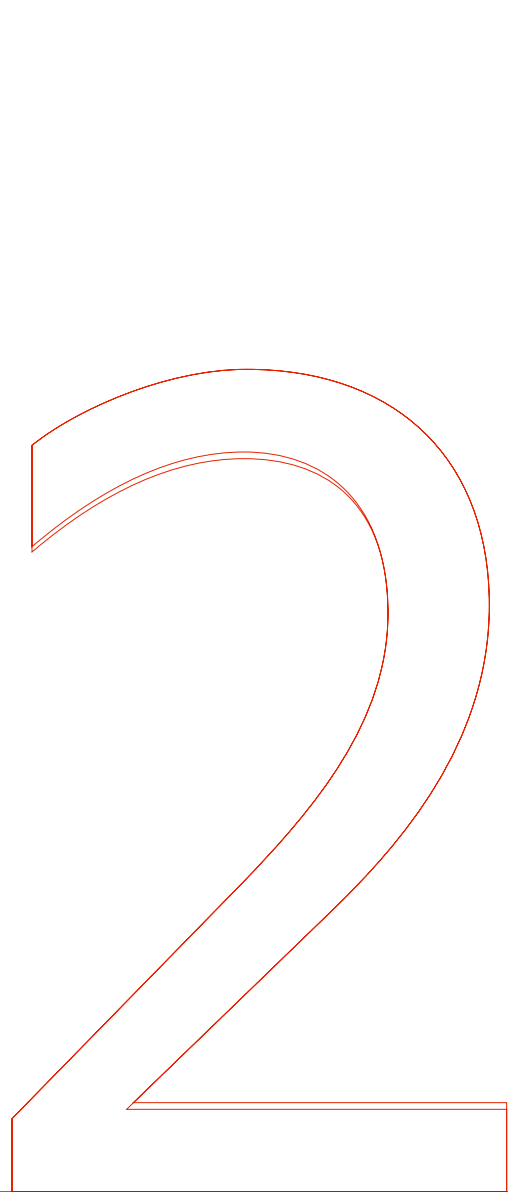
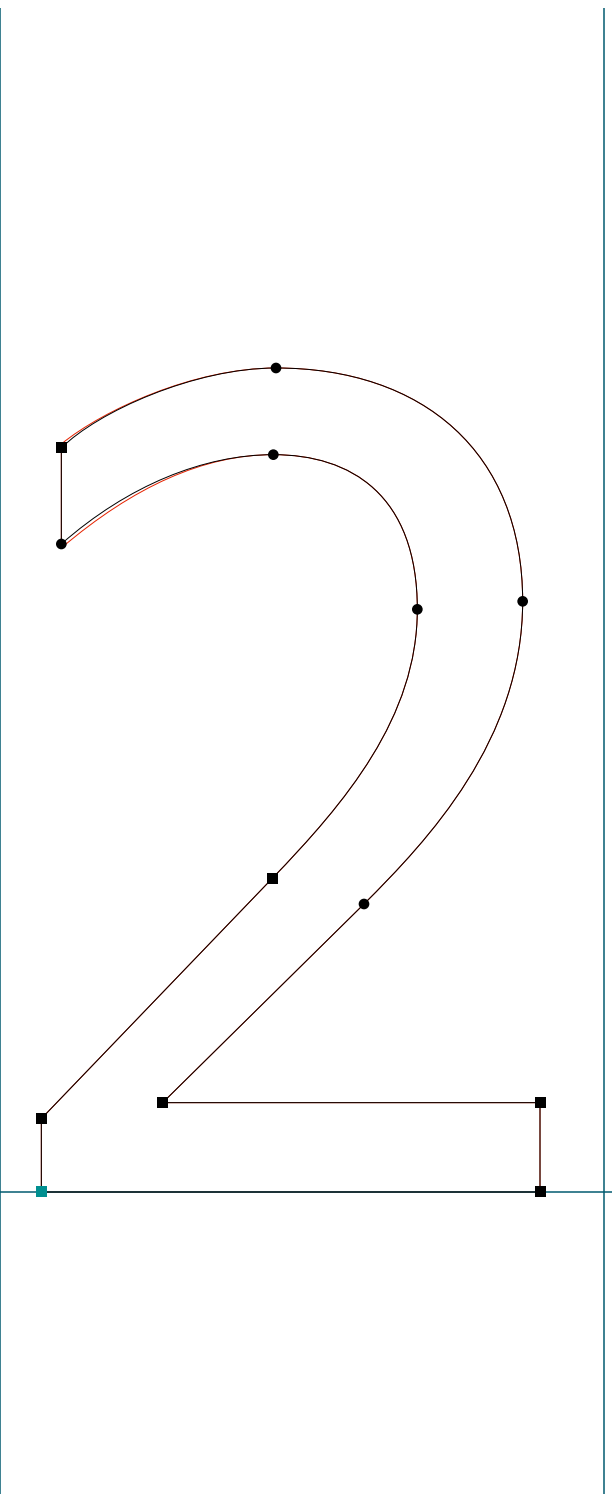

MR EAVES SANS & MODERN

.....
MrsEavesXLSan RSAVE | three | RoboFog Sketches | 2009 | Emigre Fonts

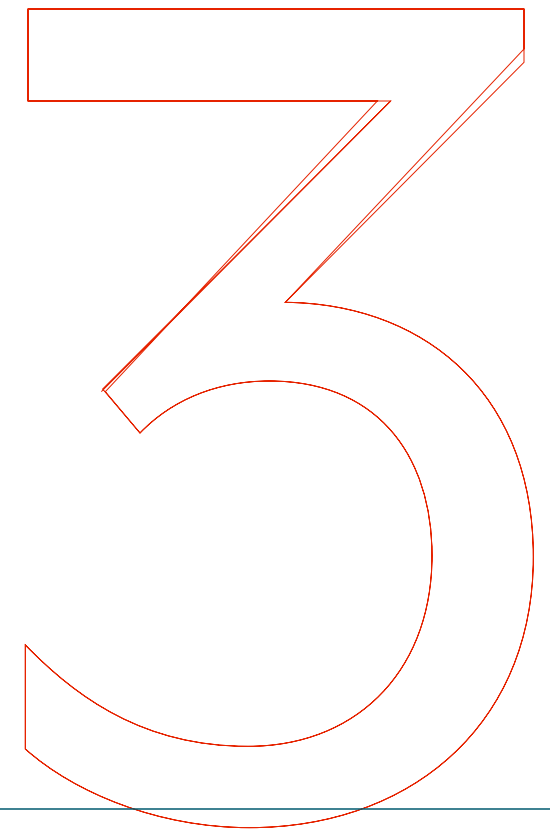
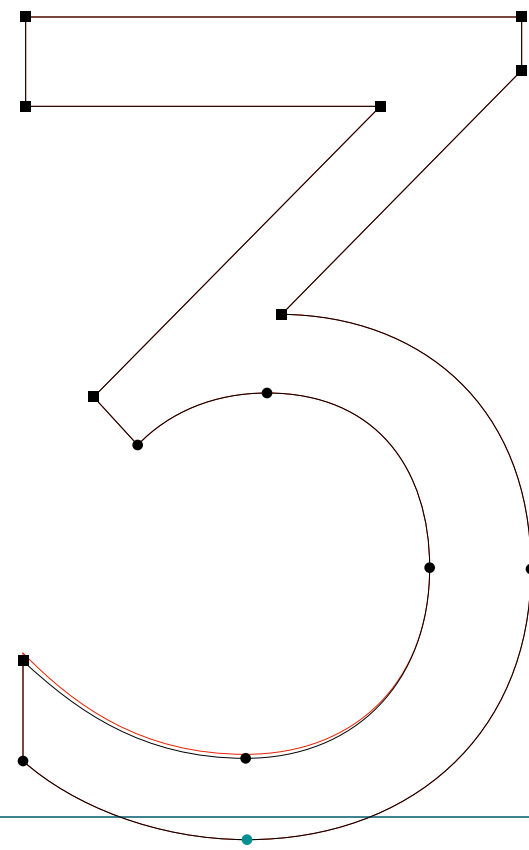

MR EAVES SANS & MODERN

.....
MrsEavesXLSan RSAVE | four | RoboFog Sketches | 2009 | Emigre Fonts

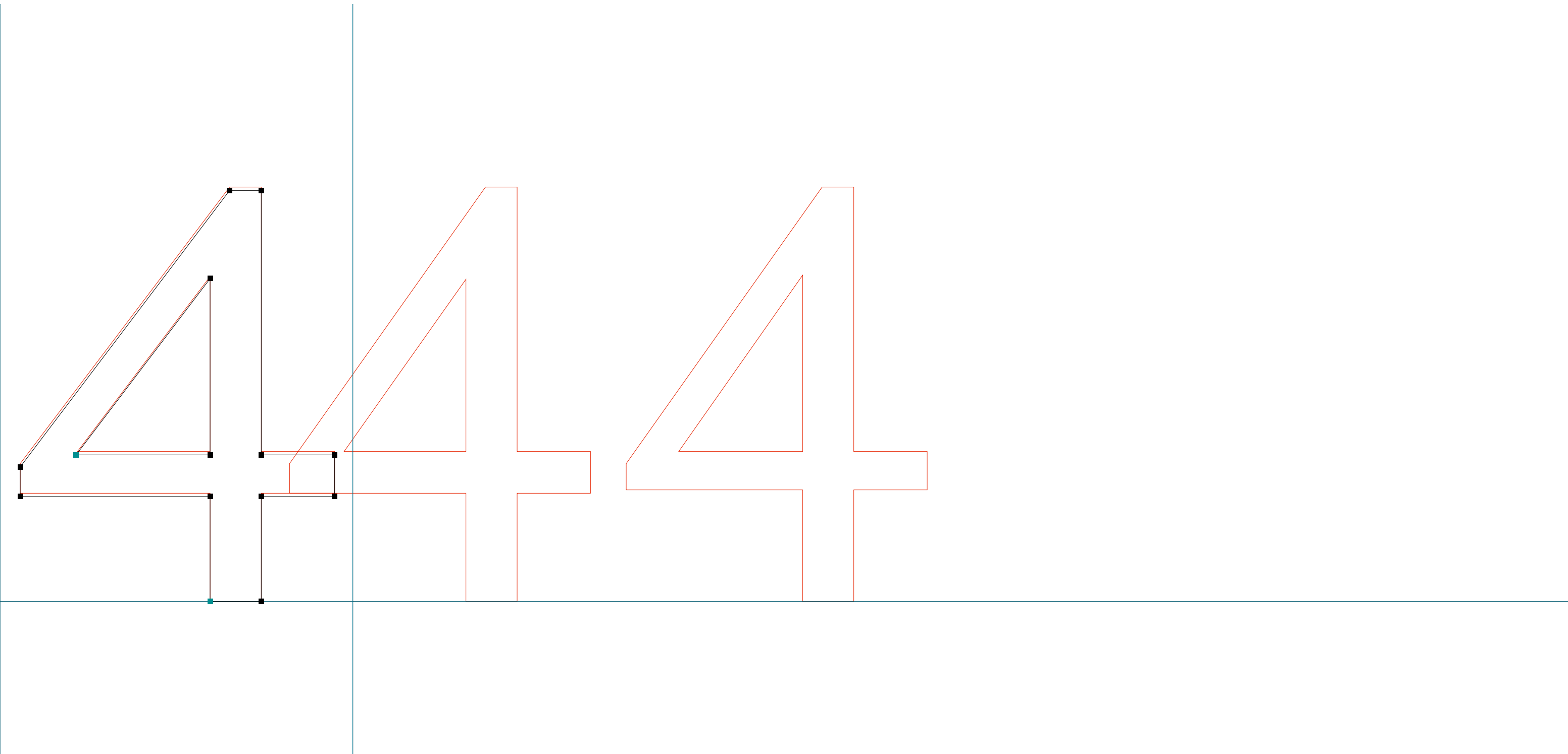

MR EAVES SANS & MODERN

.....
MrsEavesXLSan RSAVE | five | RoboFog Sketches | 2009 | Emigre Fonts

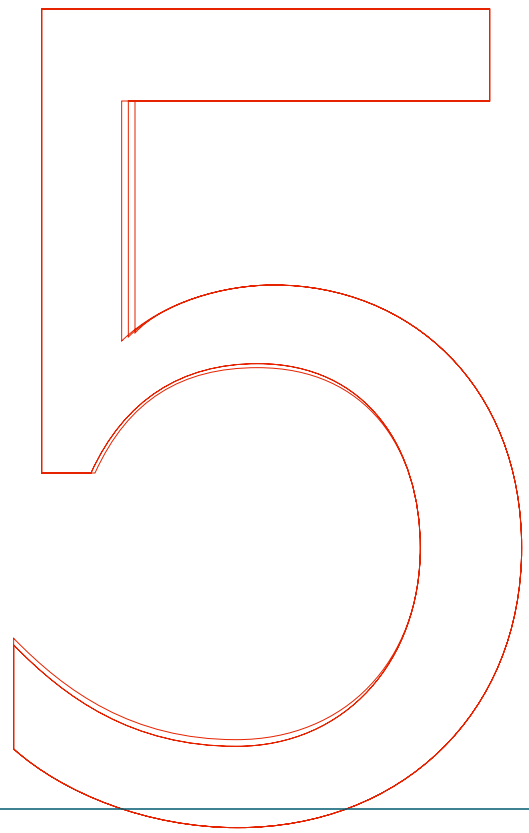
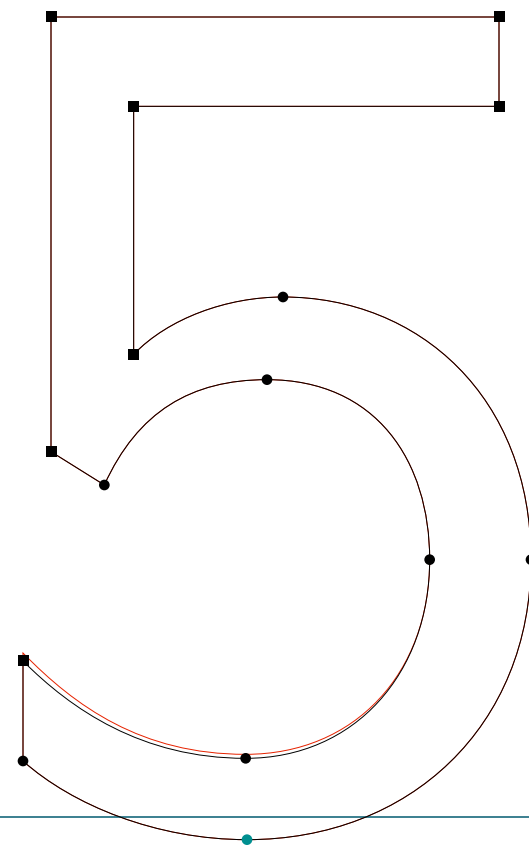

MR EAVES SANS & MODERN

.....
MrsEavesXLSan RSAVE | six | RoboFog Sketches | 2009 | Emigre Fonts

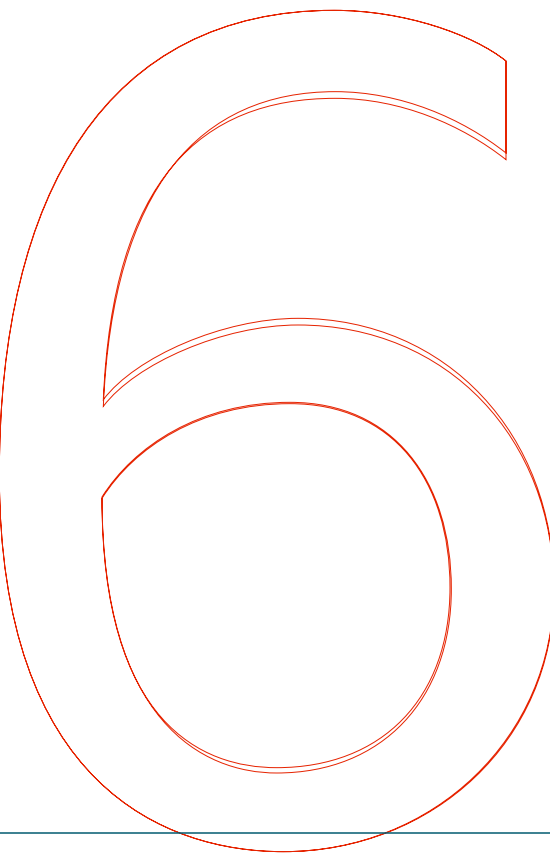
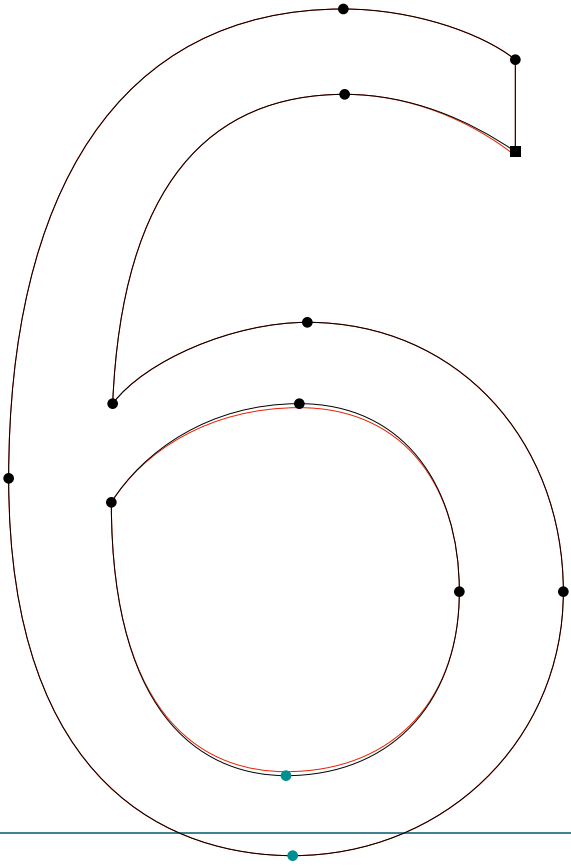

MR EAVES SANS & MODERN

.....
MrsEavesXLSan RSAVE | seven | RoboFog Sketches | 2009 | Emigre Fonts

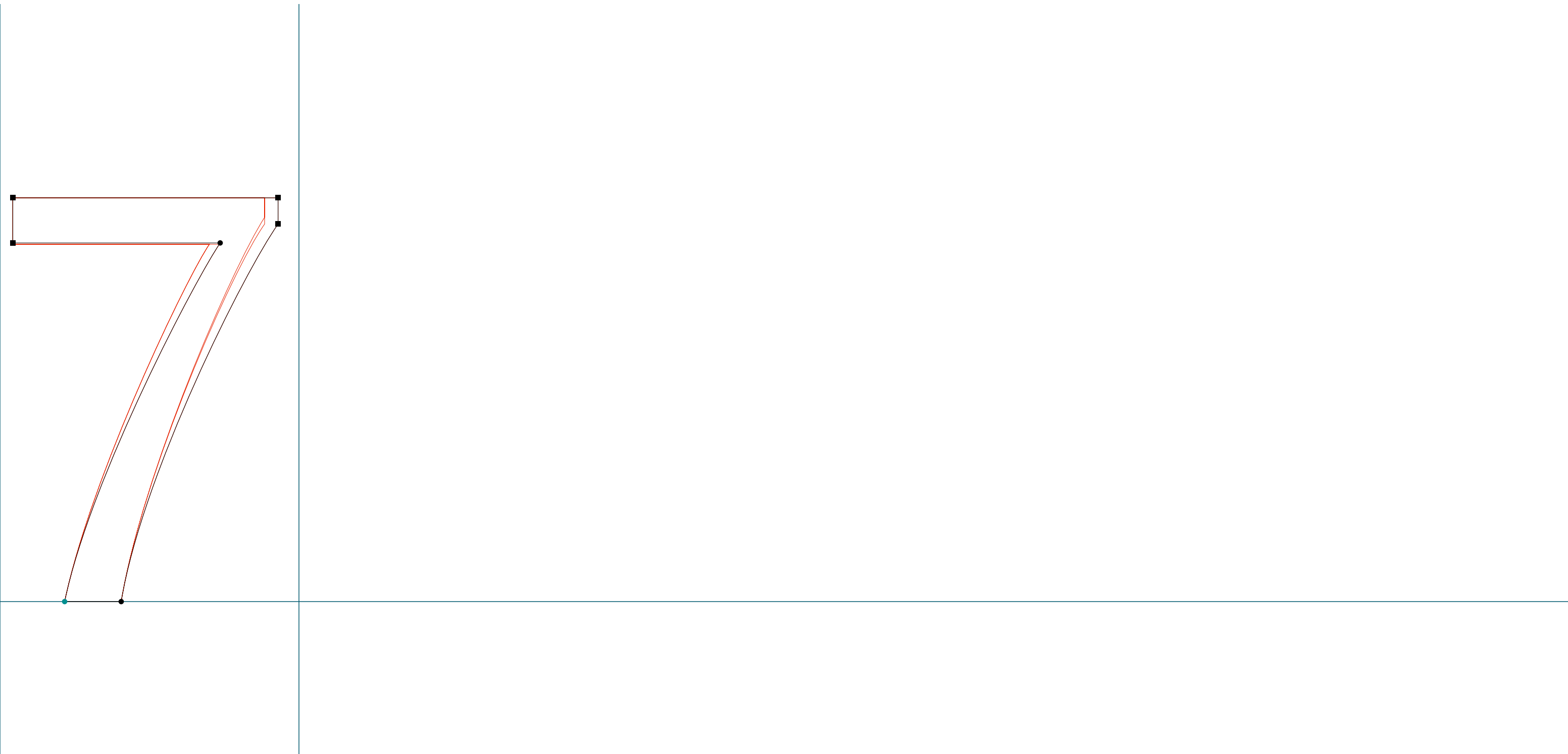

MR EAVES SANS & MODERN

.....
MrsEavesXLSan RSAVE | eight | RoboFog Sketches | 2009 | Emigre Fonts

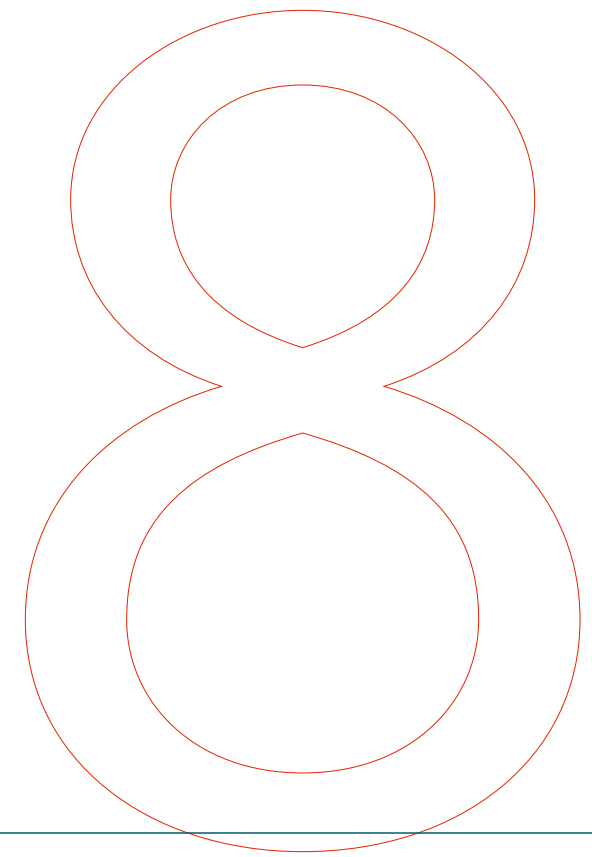
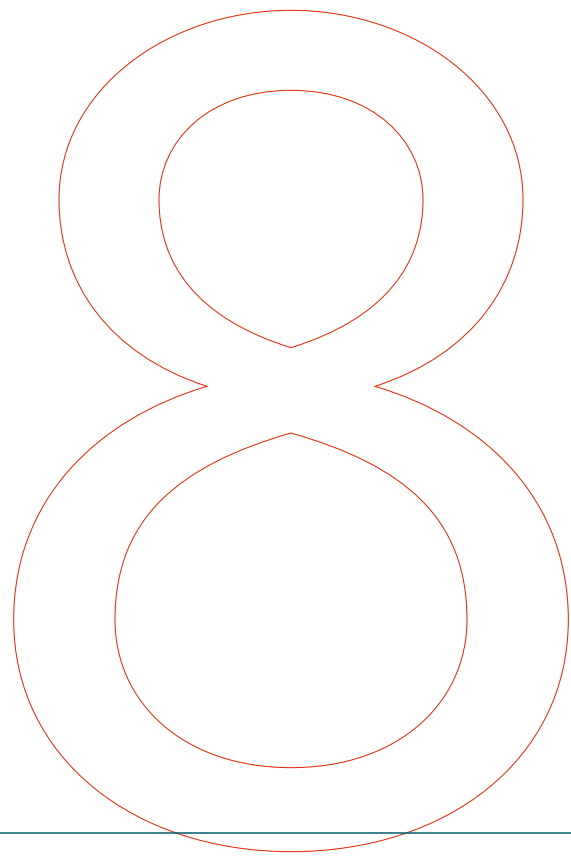
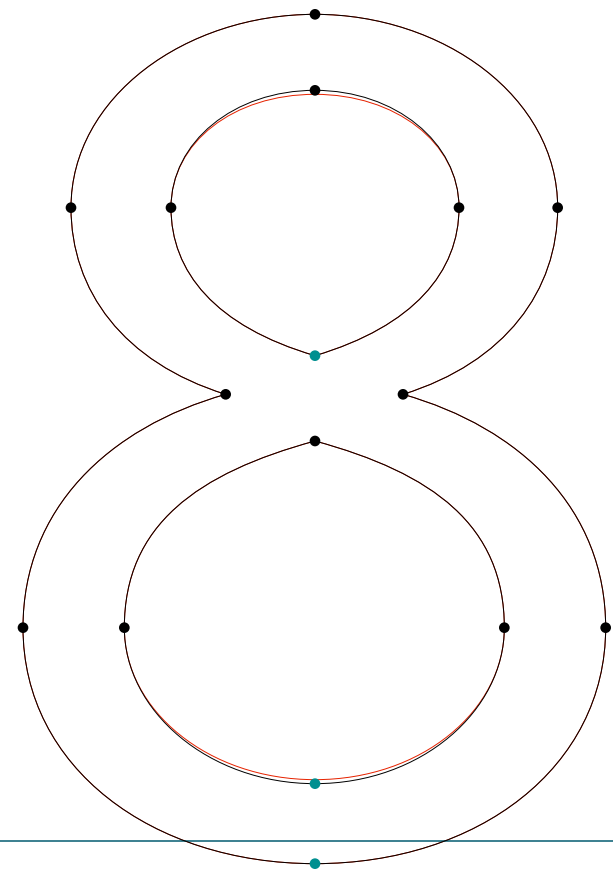

MR EAVES SANS & MODERN

.....
MrsEavesXLSan RSAVE | nine | RoboFog Sketches | 2009 | Emigre Fonts

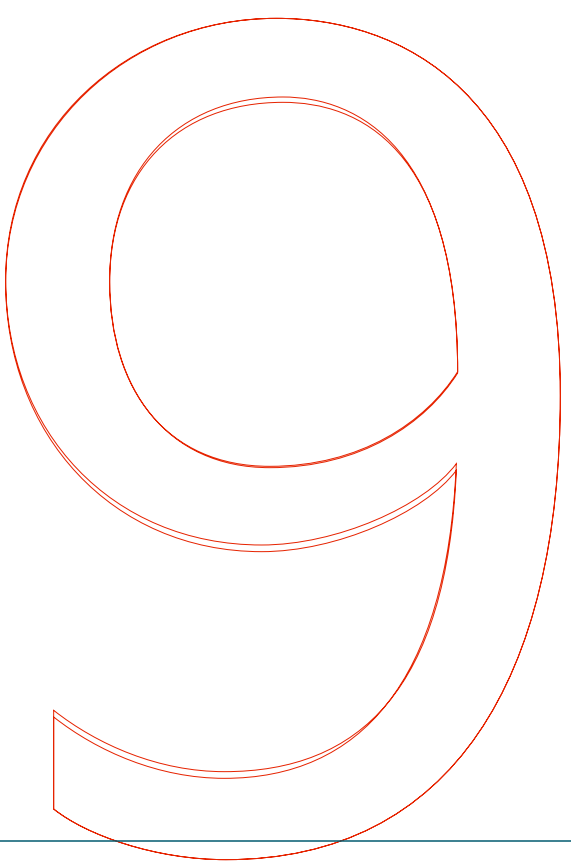
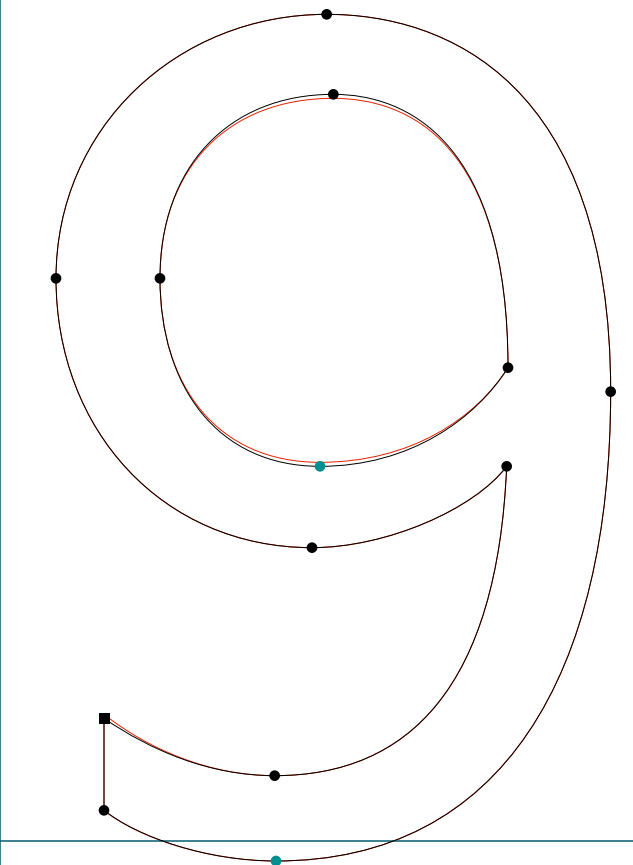

MR EAVES SANS & MODERN

.....
MrsEavesXLSan RSAVE | semicolon | RoboFog Sketches | 2009 | Emigre Fonts

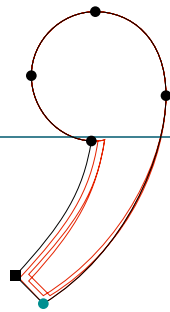
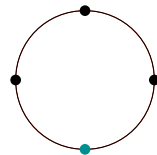

MR EAVES SANS & MODERN

.....
MrsEavesXLSan RSAVE | question | RoboFog Sketches | 2009 | Emigre Fonts

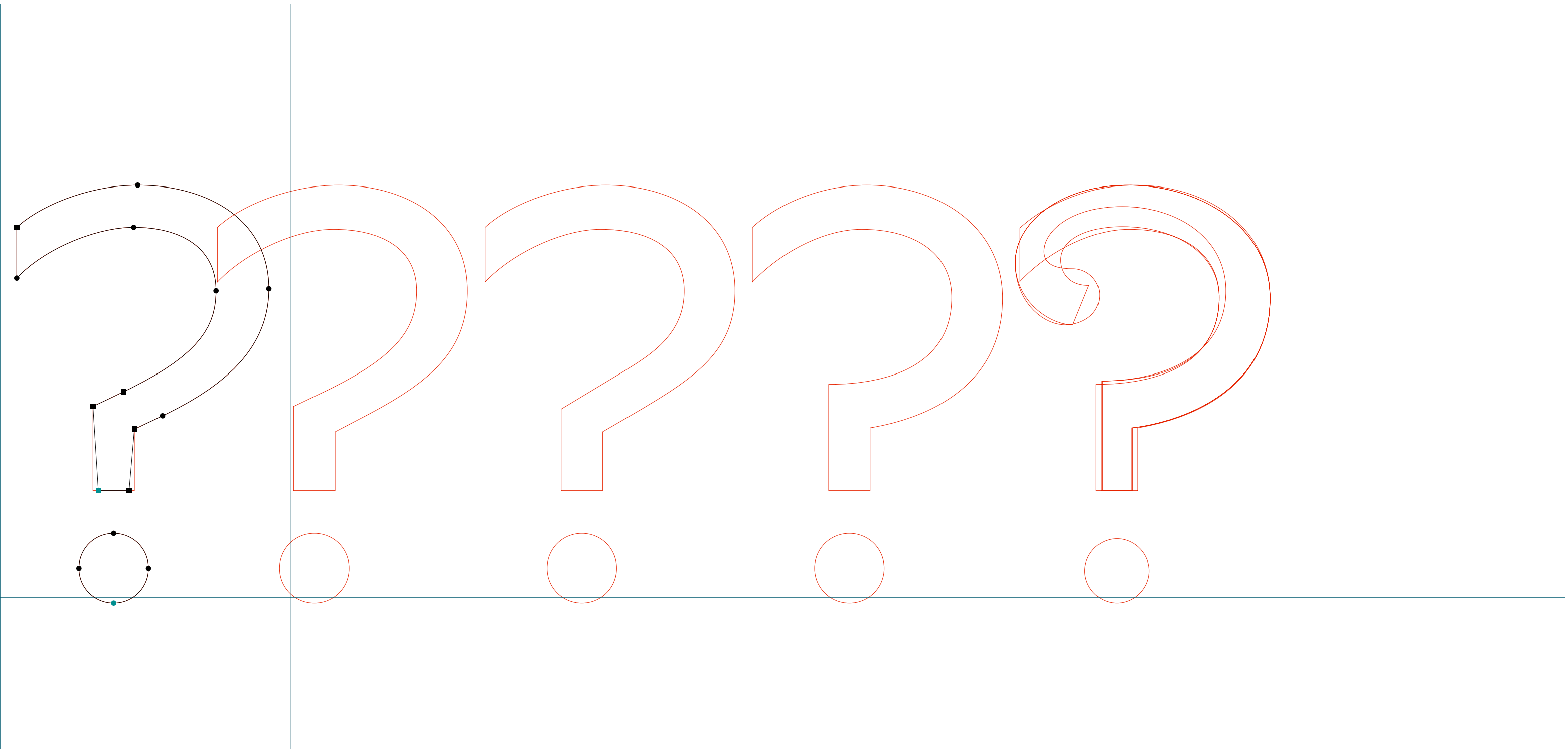

MR EAVES SANS & MODERN

MrsEavesXLSan RSAVE | at | RoboFog Sketches | 2009 | Emigre Fonts

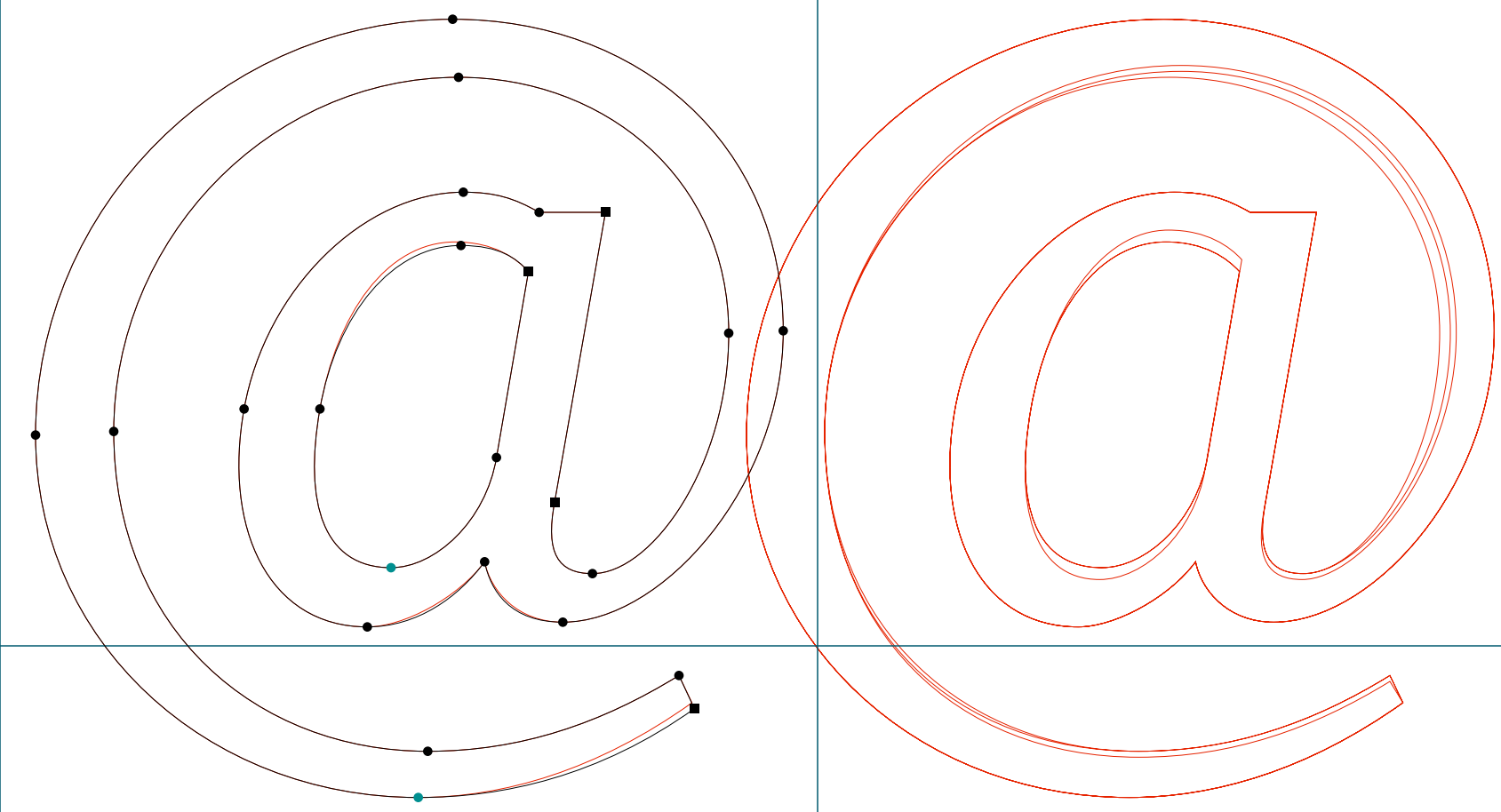

MR EAVES SANS & MODERN

.....
MrsEavesXLSan RSAVE | A | RoboFog Sketches | 2009 | Emigre Fonts

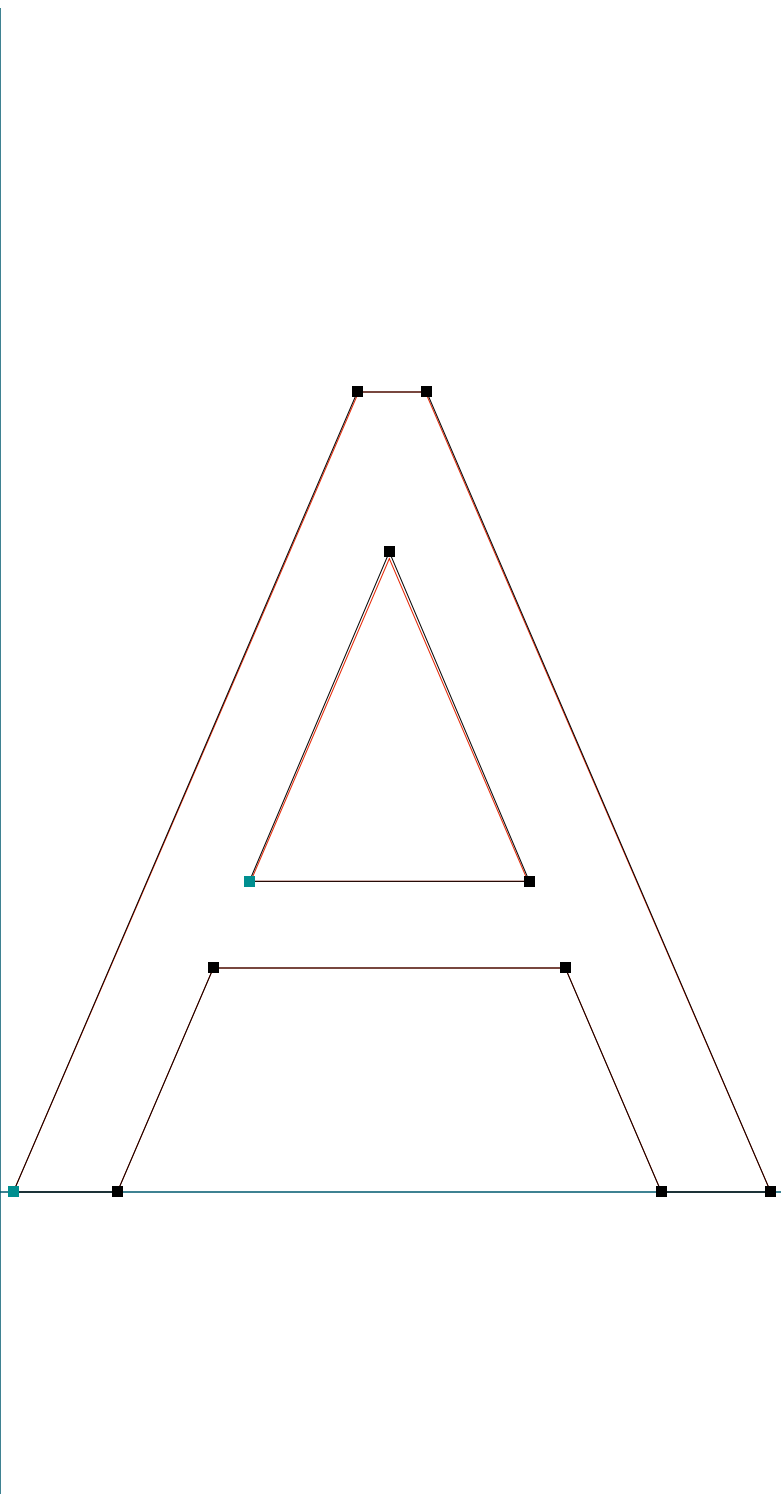

MR EAVES SANS & MODERN

.....
MrsEavesXLSan RSAVE | C | RoboFog Sketches | 2009 | Emigre Fonts

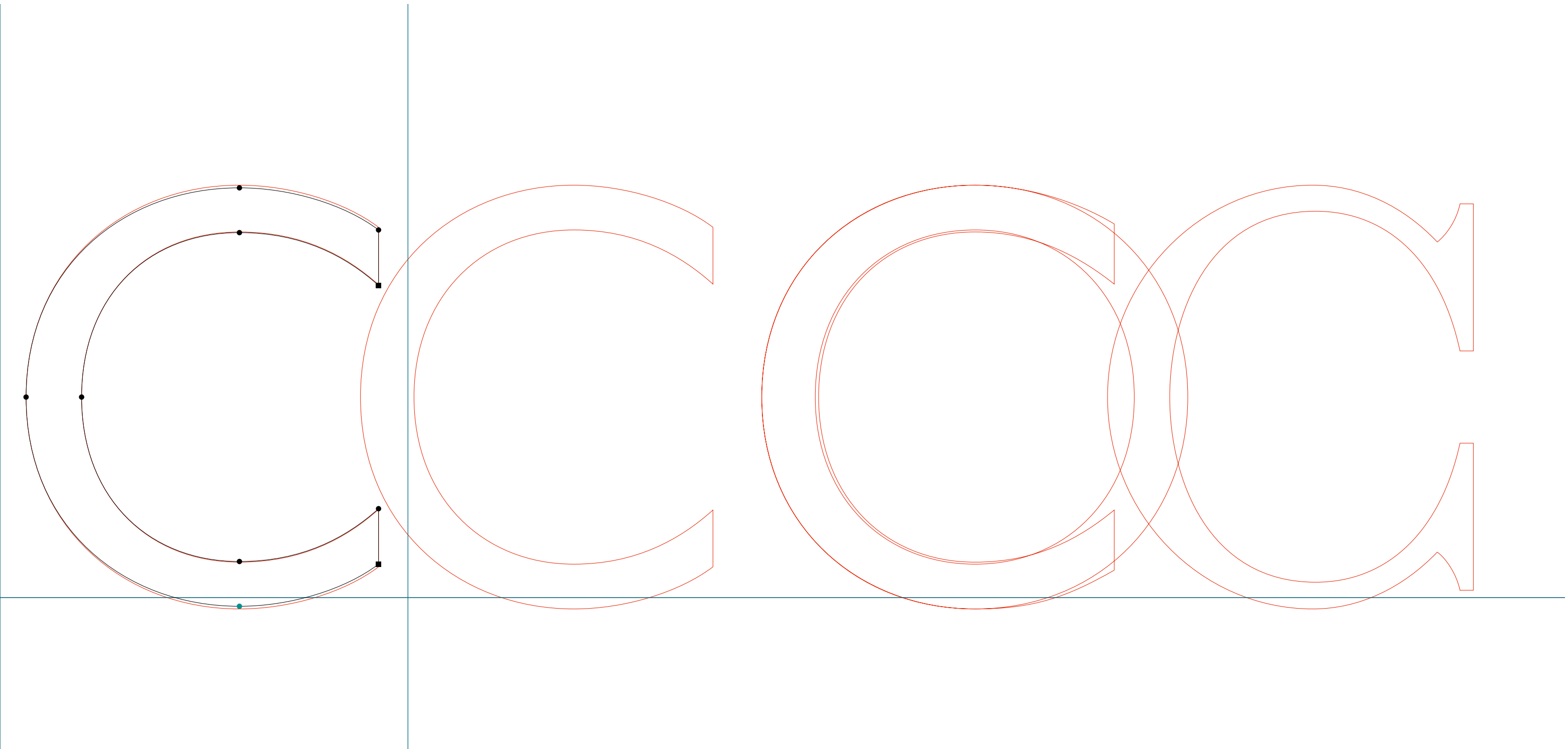

MR EAVES SANS & MODERN

MrsEavesXLSan RSAVE | G | RoboFog Sketches | 2009 | Emigre Fonts

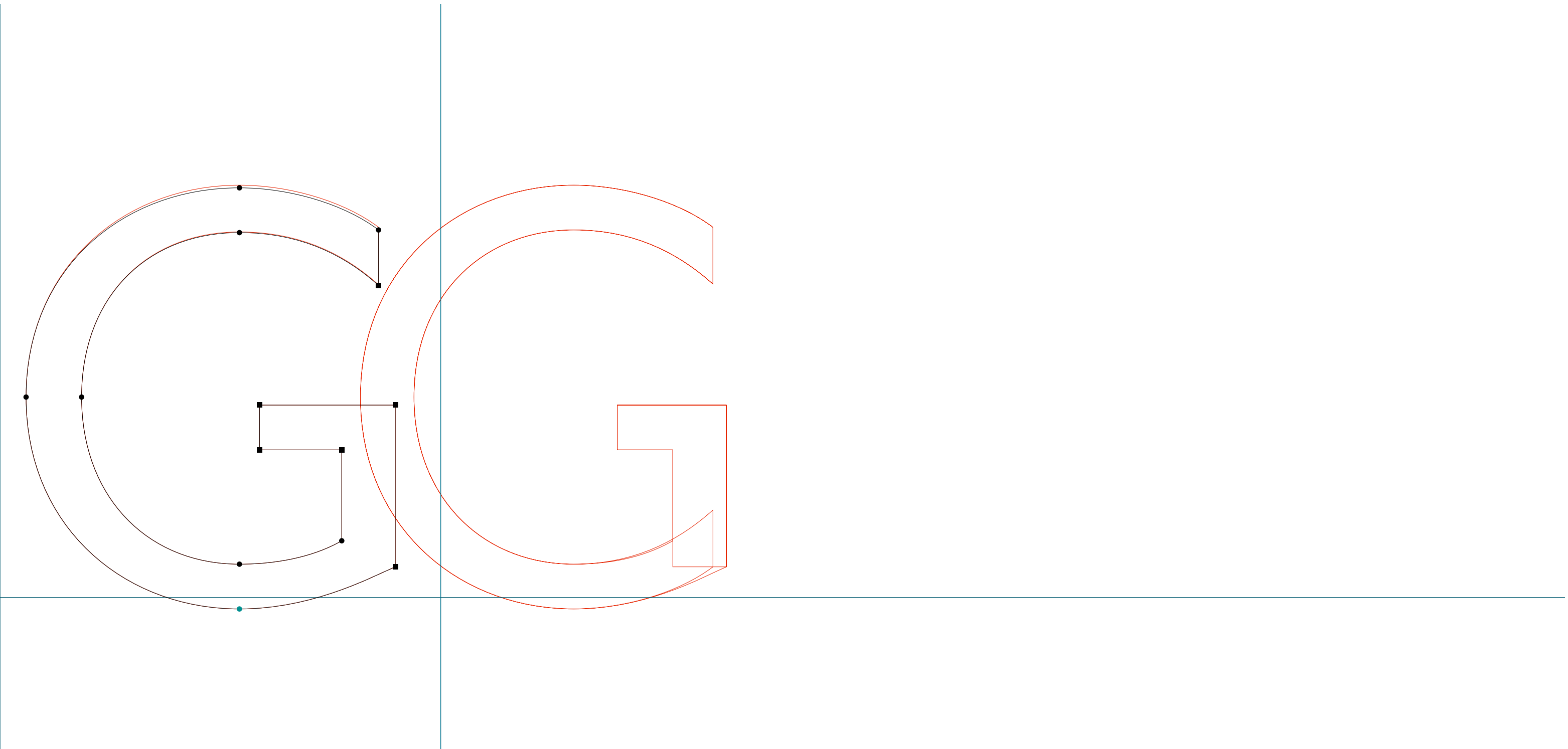

MR EAVES SANS & MODERN

.....
MrsEavesXLSan RSAVE | J | RoboFog Sketches | 2009 | Emigre Fonts

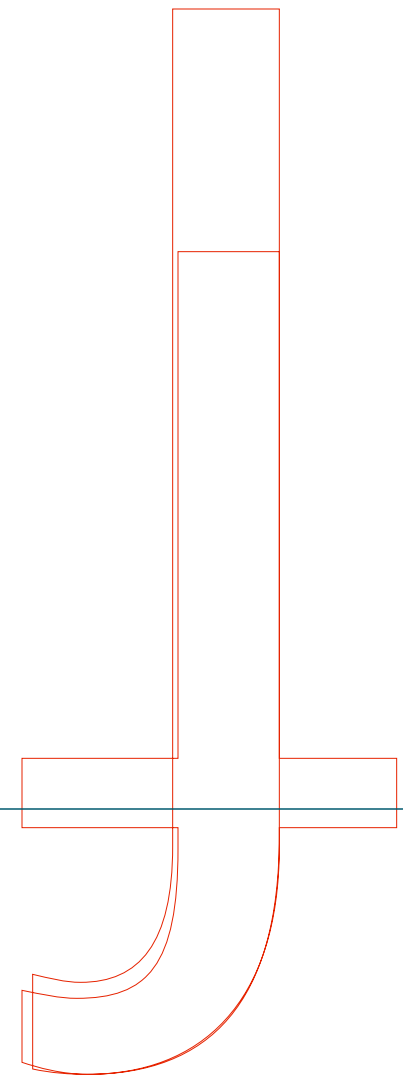
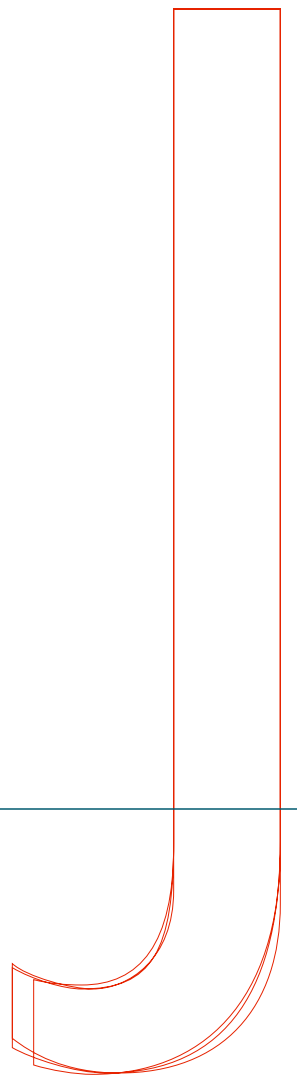
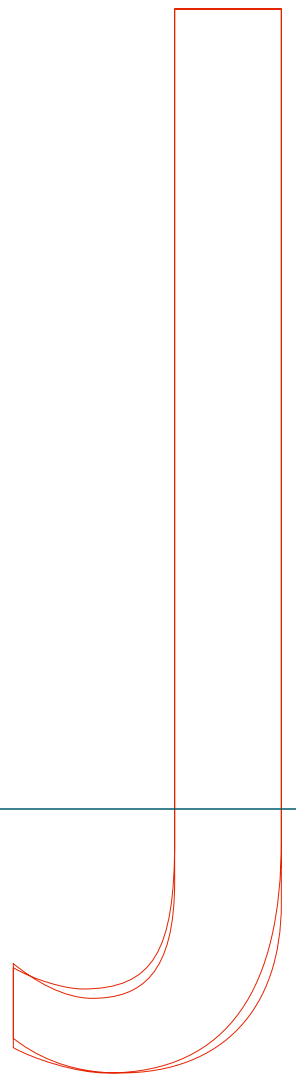
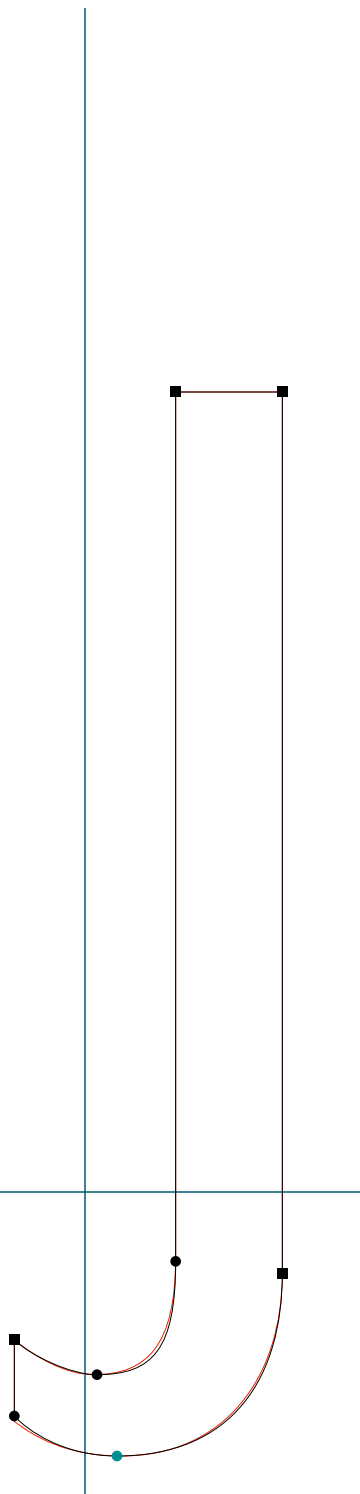

MR EAVES SANS & MODERN

.....
MrsEavesXLSan RSAVE | K | RoboFog Sketches | 2009 | Emigre Fonts

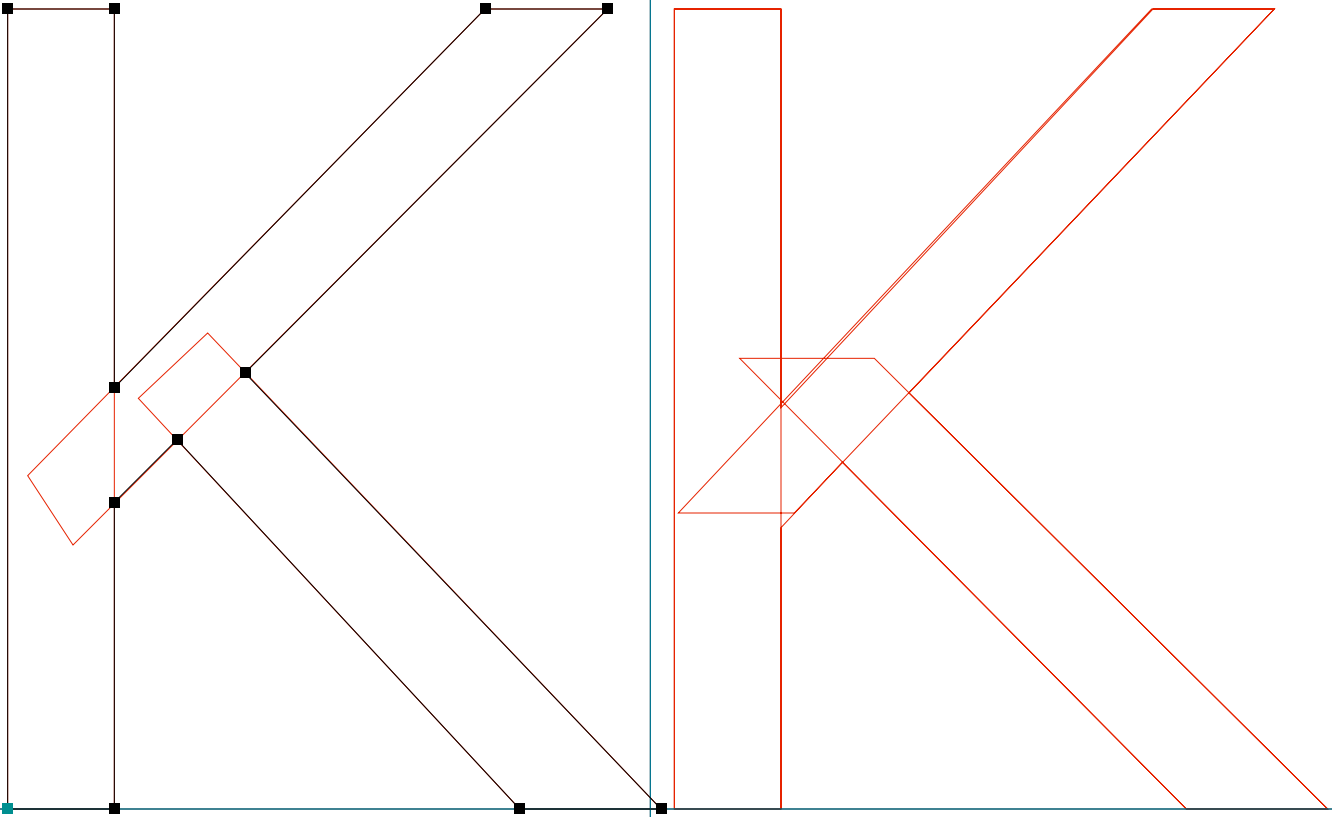

MR EAVES SANS & MODERN

.....
MrsEavesXLSan RSAVE | M | RoboFog Sketches | 2009 | Emigre Fonts

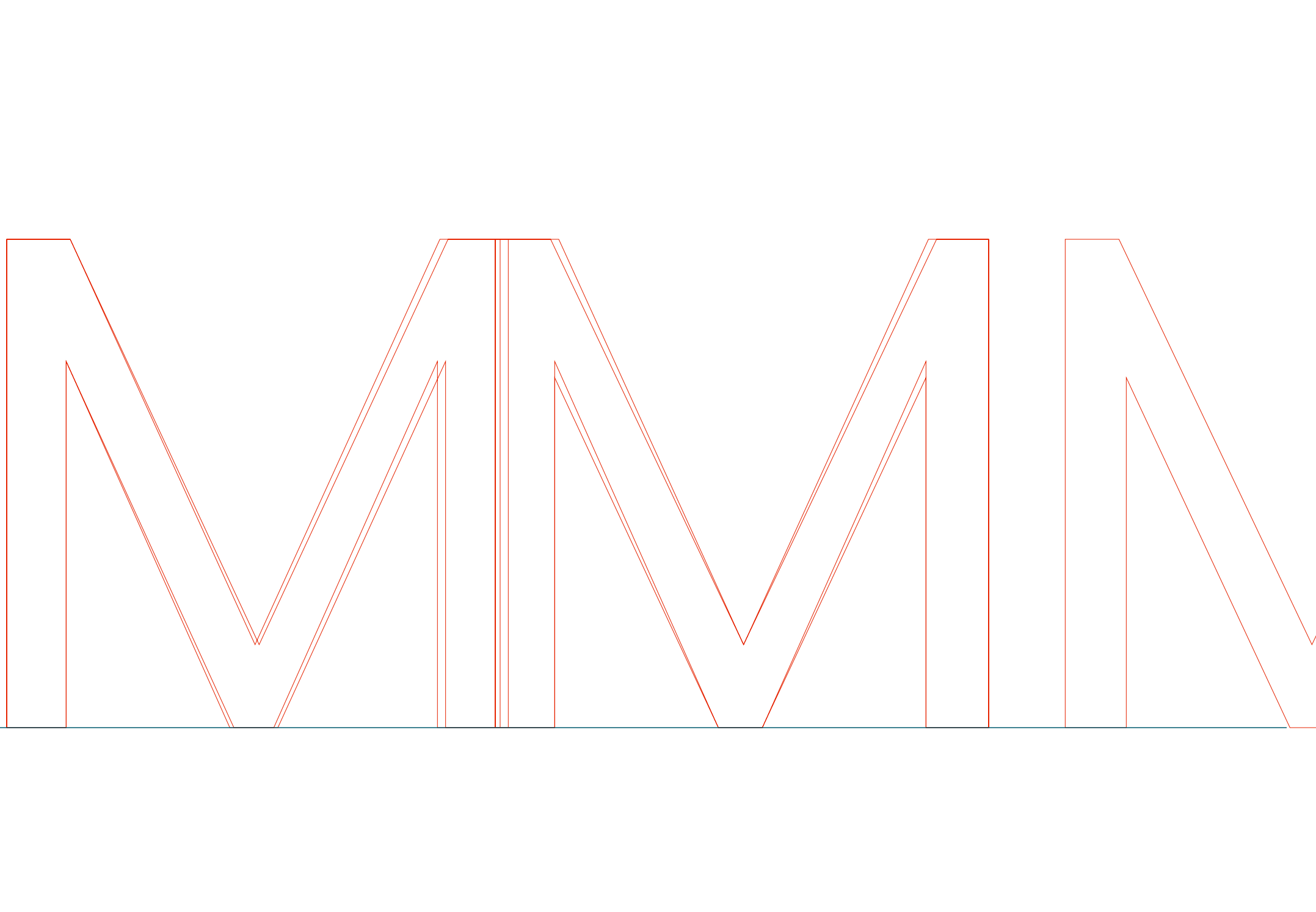
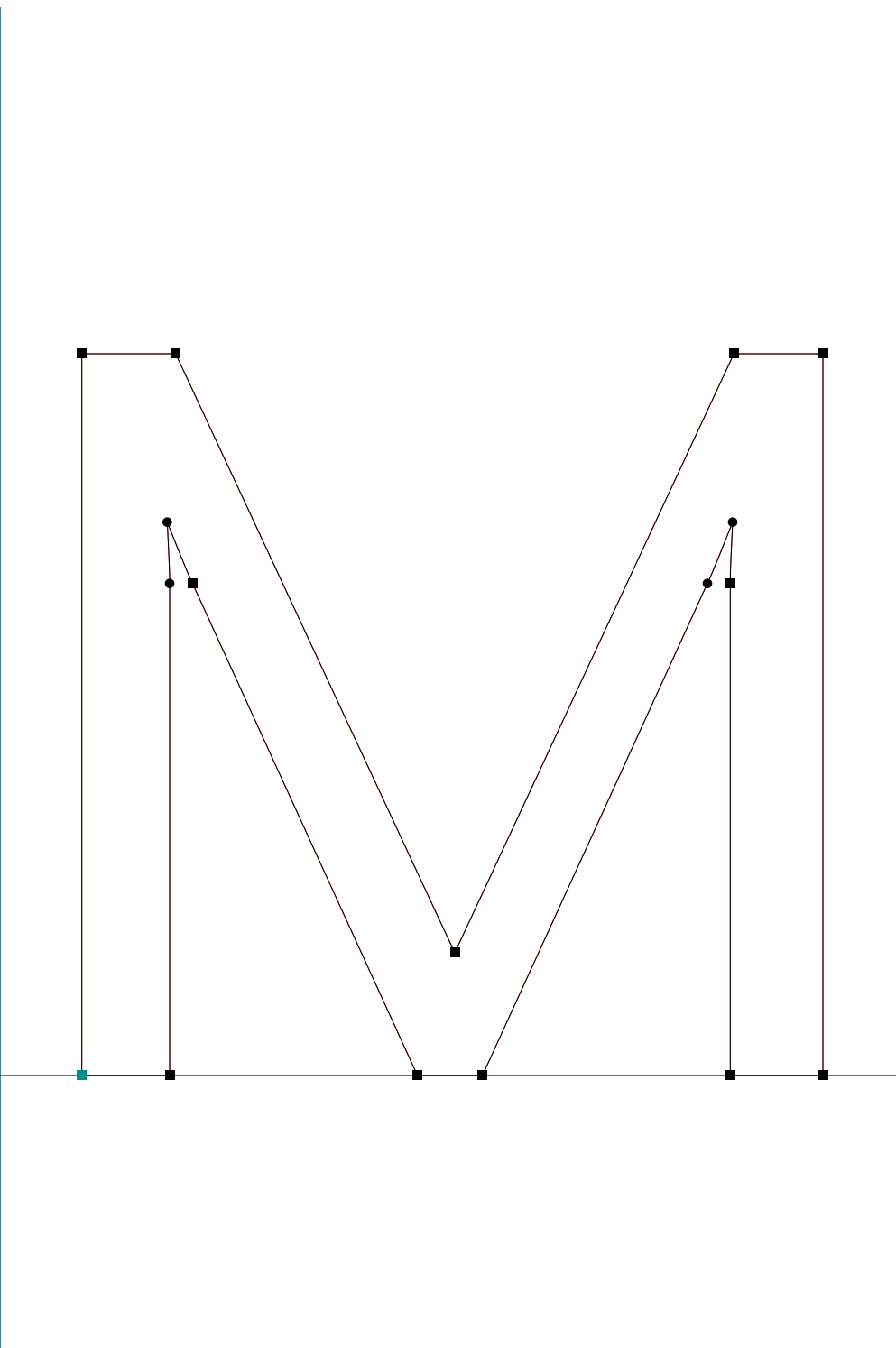

MR EAVES SANS & MODERN

.....
MrsEavesXLSan RSAVE | O | RoboFog Sketches | 2009 | Emigre Fonts

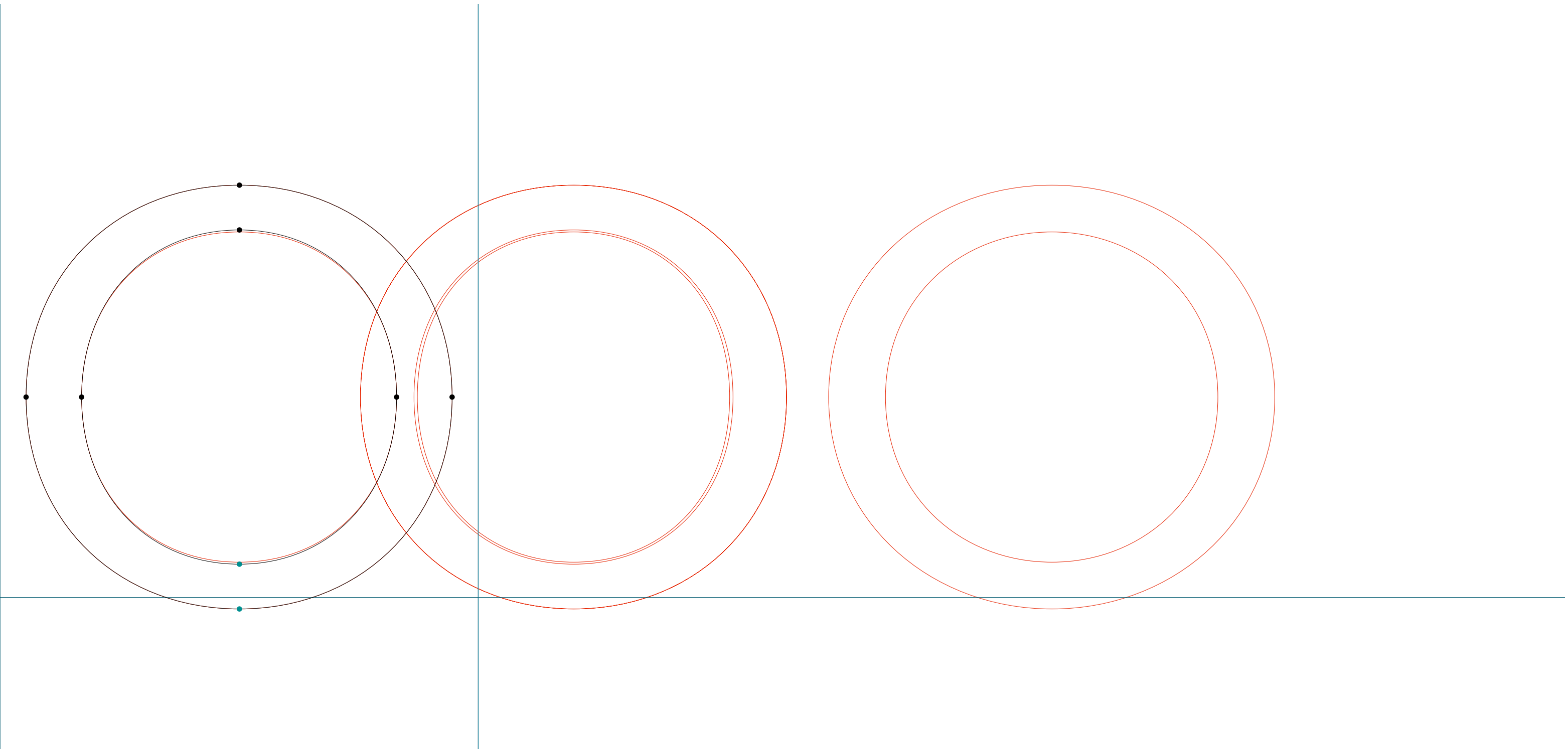

MR EAVES SANS & MODERN

.....
MrsEavesXLSan RSAVE | P | RoboFog Sketches | 2009 | Emigre Fonts

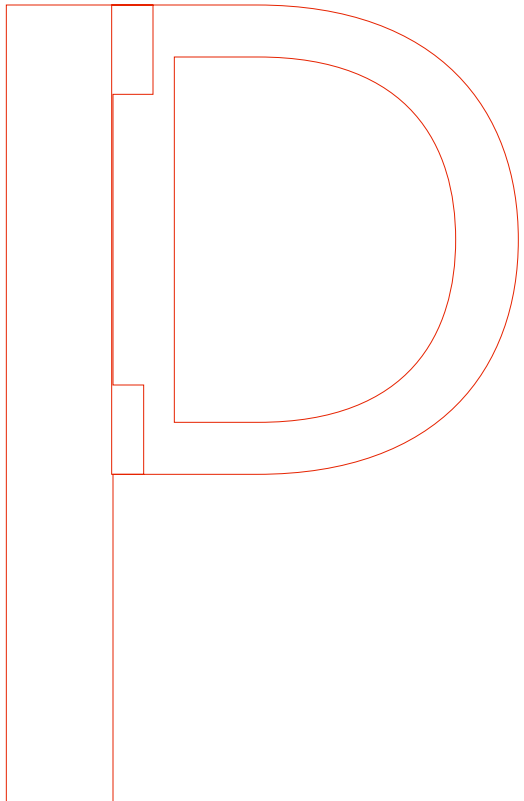
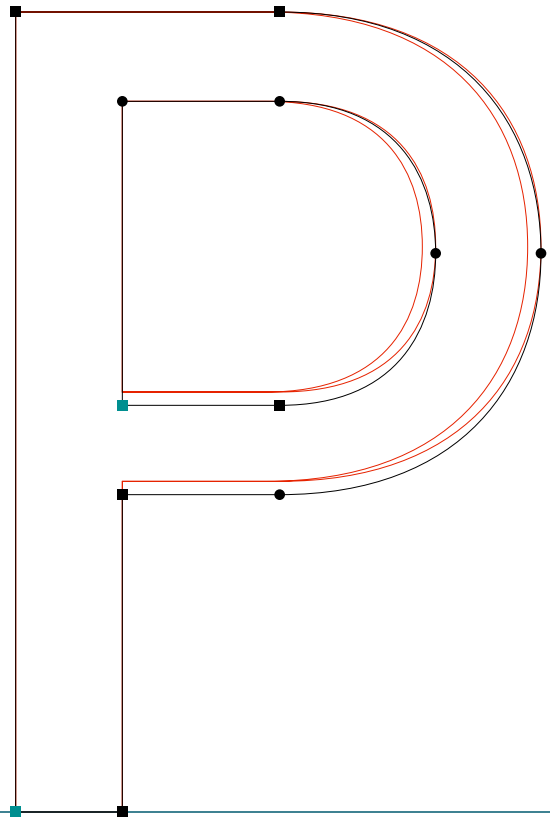

MR EAVES SANS & MODERN

.....
MrsEavesXLSan RSAVE | Q | RoboFog Sketches | 2009 | Emigre Fonts

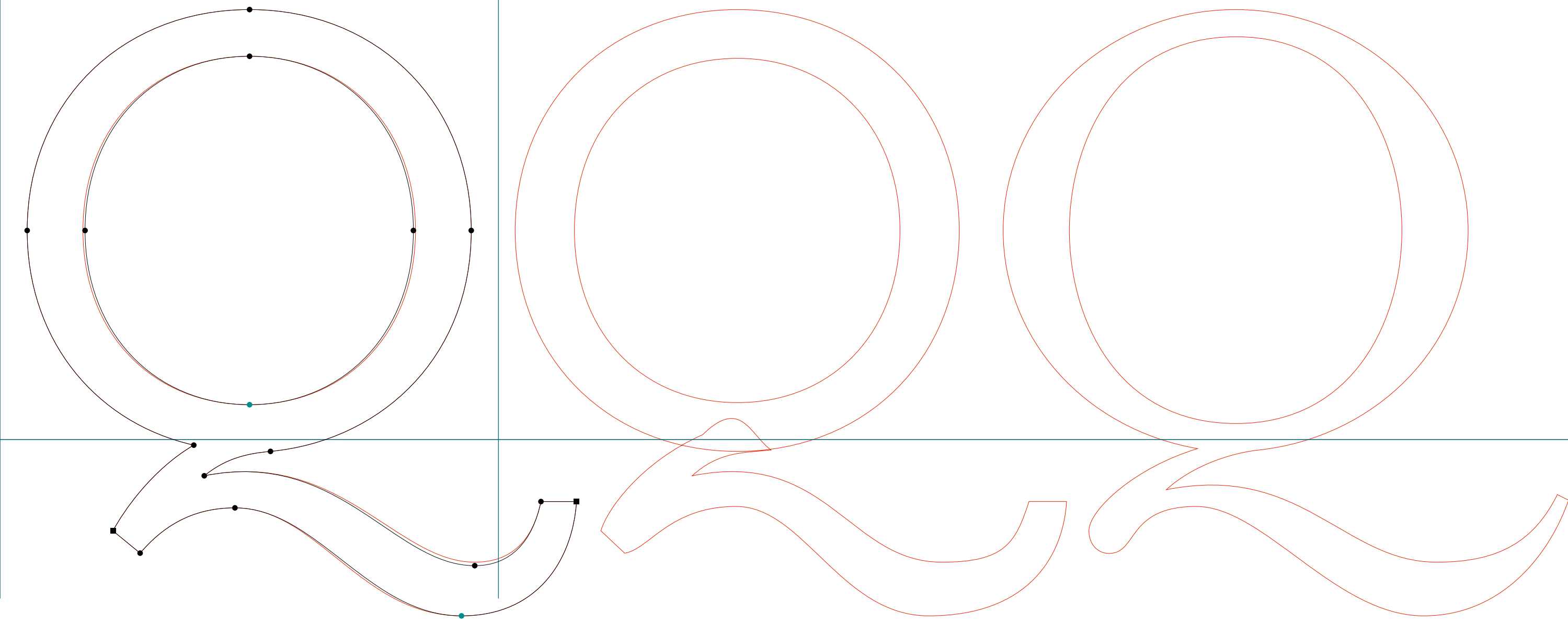

MR EAVES SANS & MODERN

.....
MrsEavesXLSan RSAVE | R | RoboFog Sketches | 2009 | Emigre Fonts

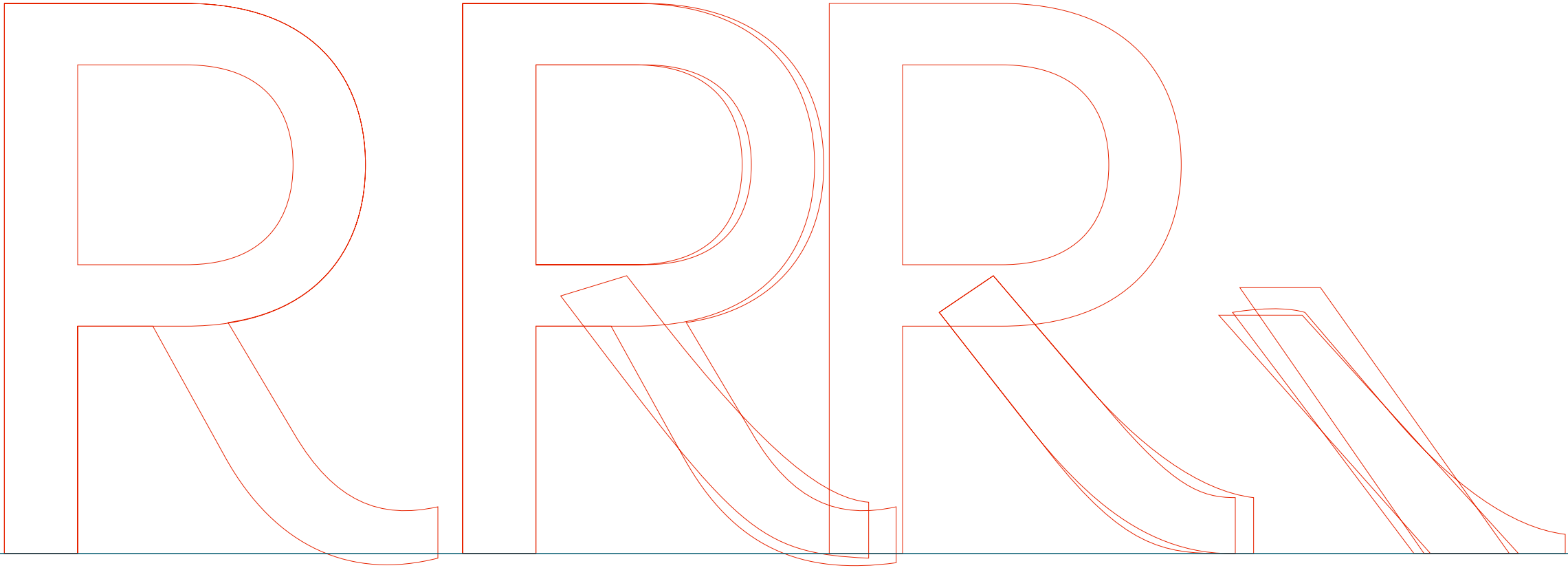
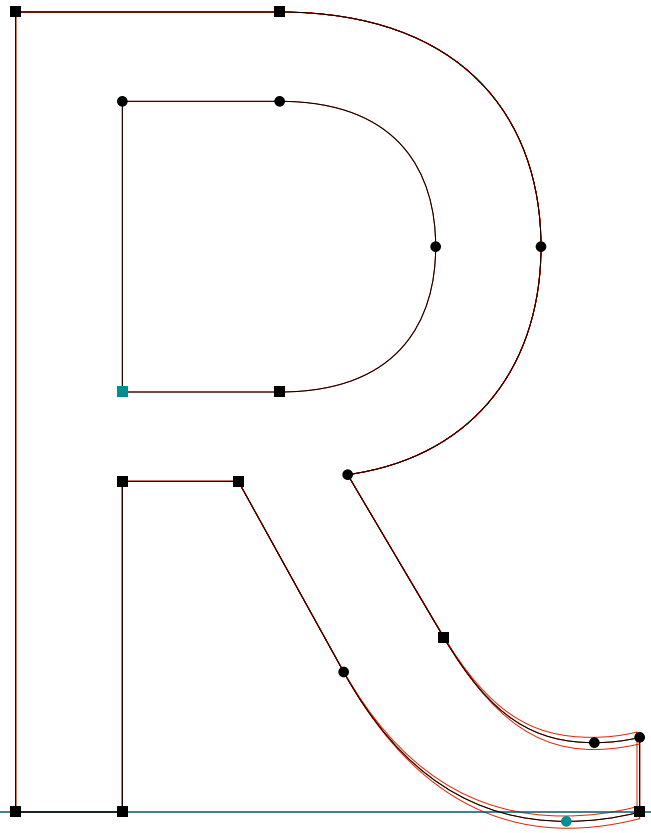

MR EAVES SANS & MODERN

.....
MrsEavesXLSan RSAVE | S | RoboFog Sketches | 2009 | Emigre Fonts

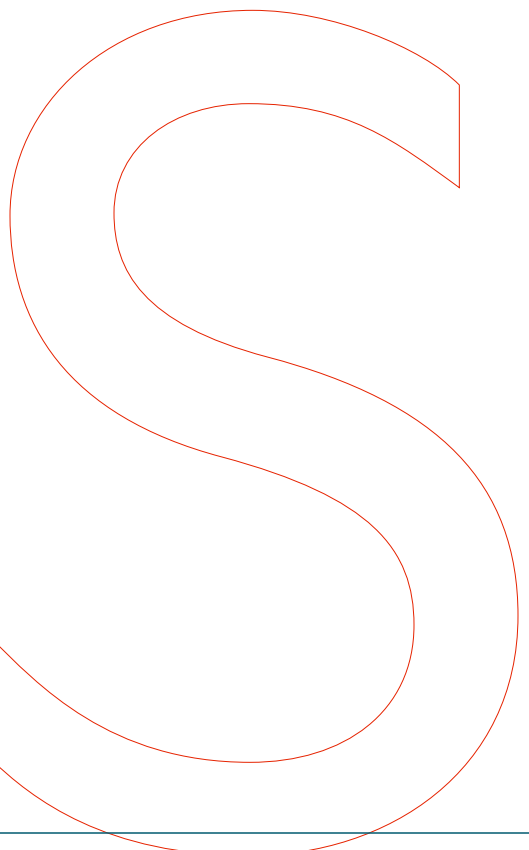
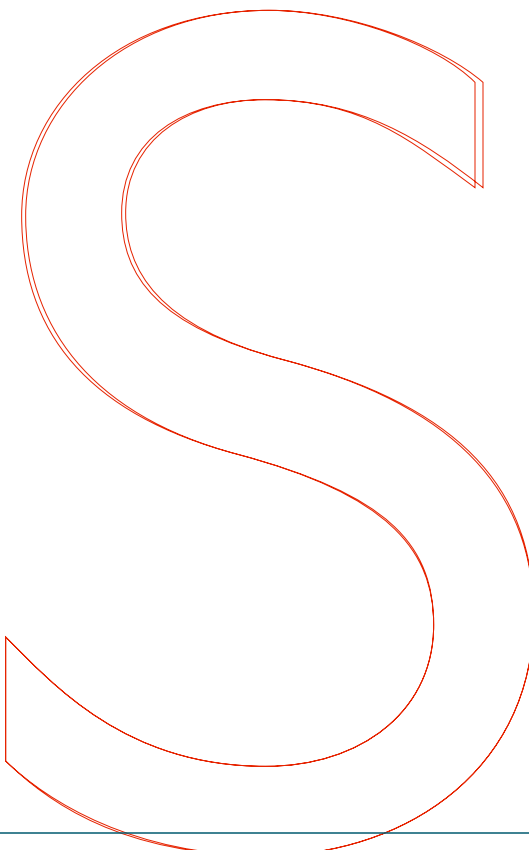
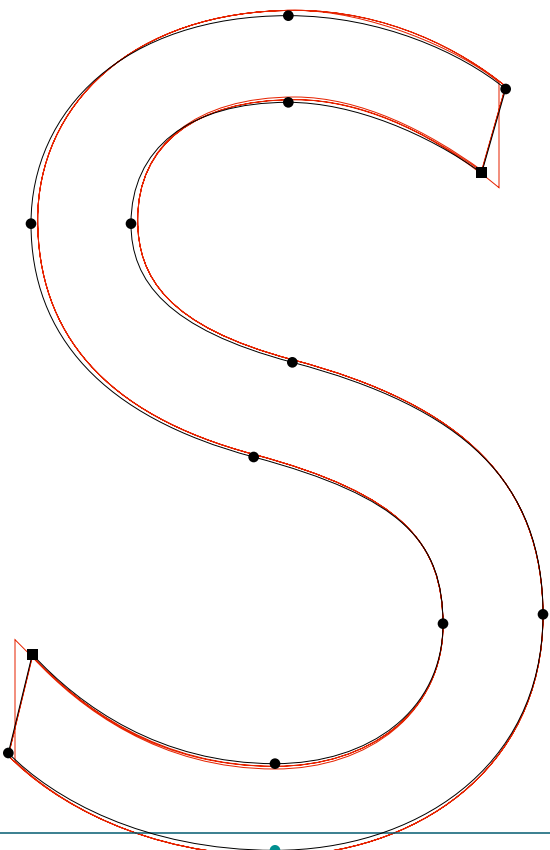
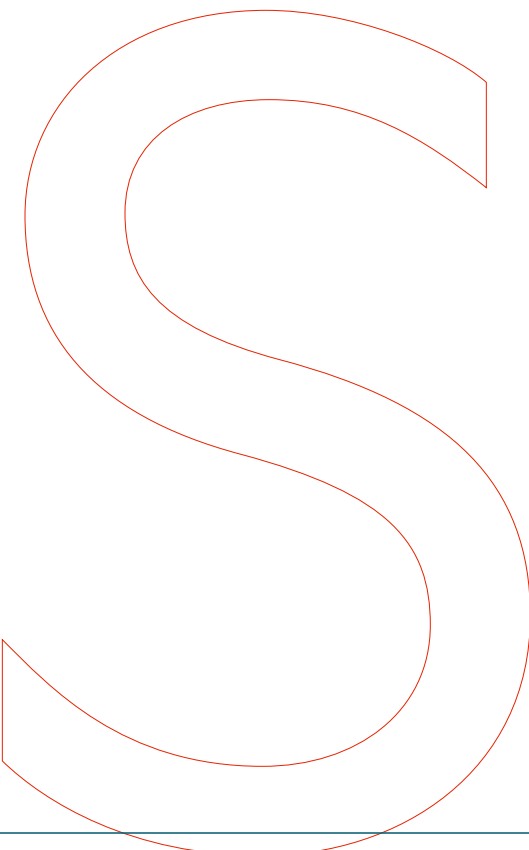

MR EAVES SANS & MODERN

.....
MrsEavesXLSan RSAVE | U | RoboFog Sketches | 2009 | Emigre Fonts

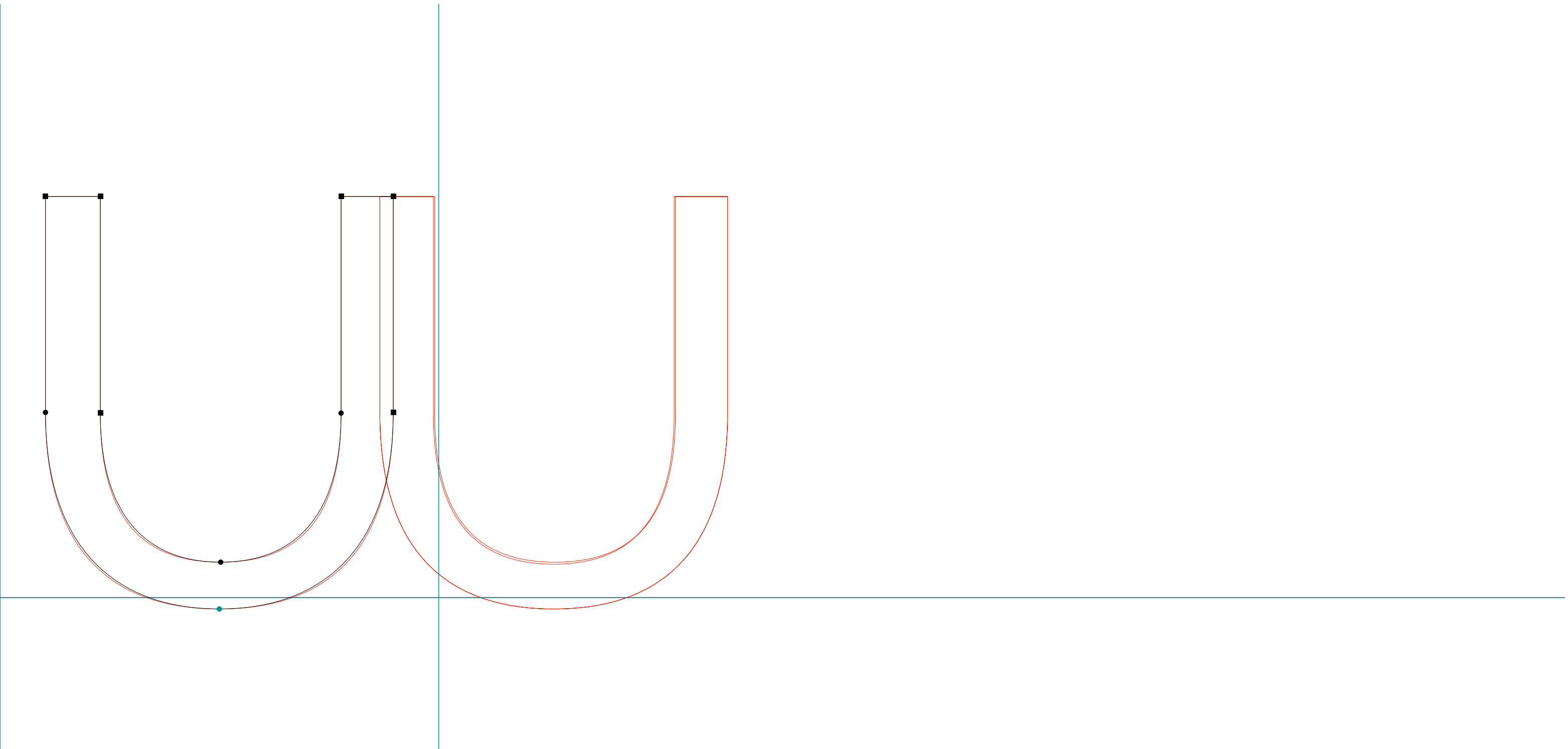

MR EAVES SANS & MODERN

.....
MrsEavesXLSan RSAVE | V | RoboFog Sketches | 2009 | Emigre Fonts

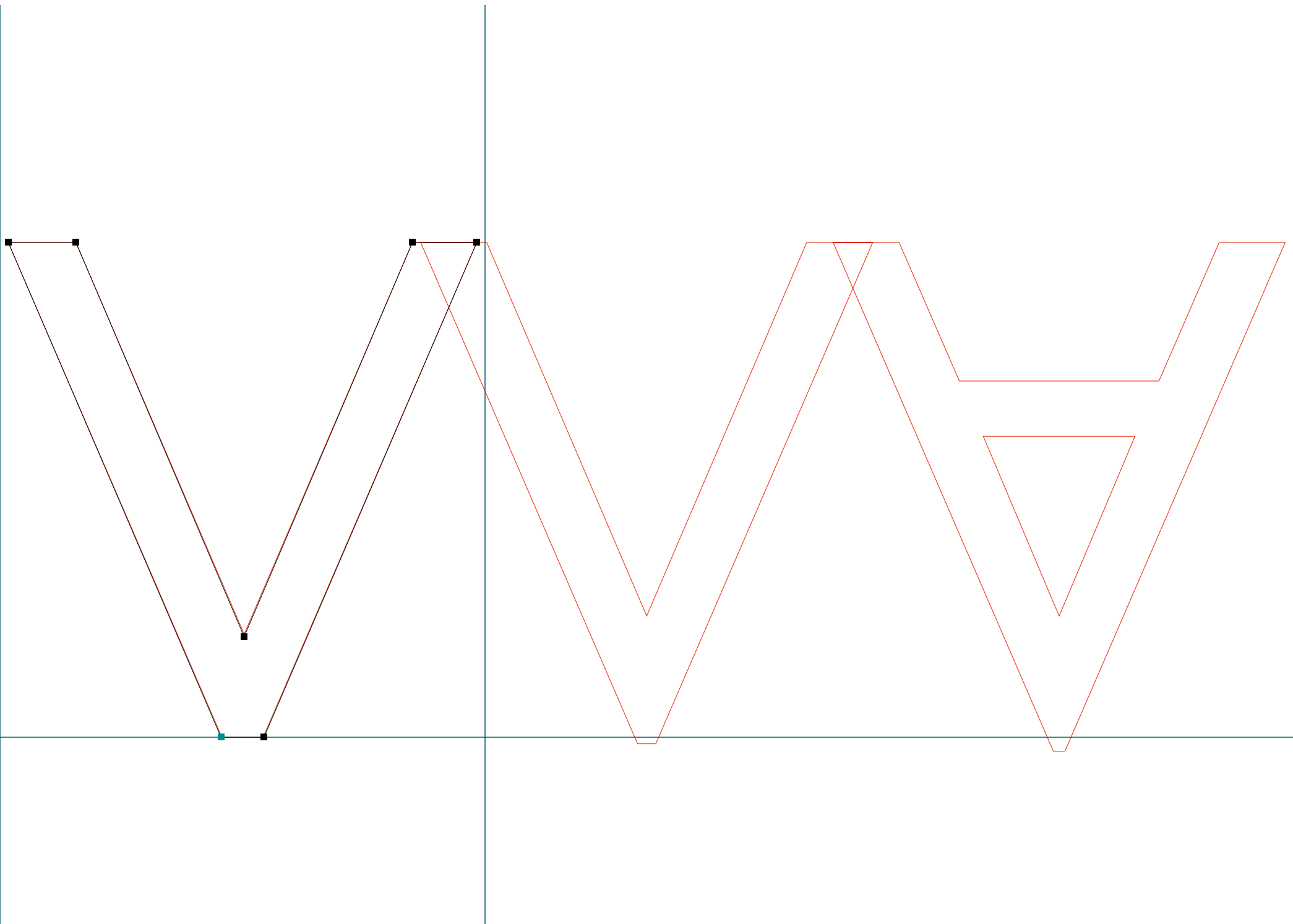

MR EAVES SANS & MODERN

.....
MrsEavesXLSan RSAVE | W | RoboFog Sketches | 2009 | Emigre Fonts

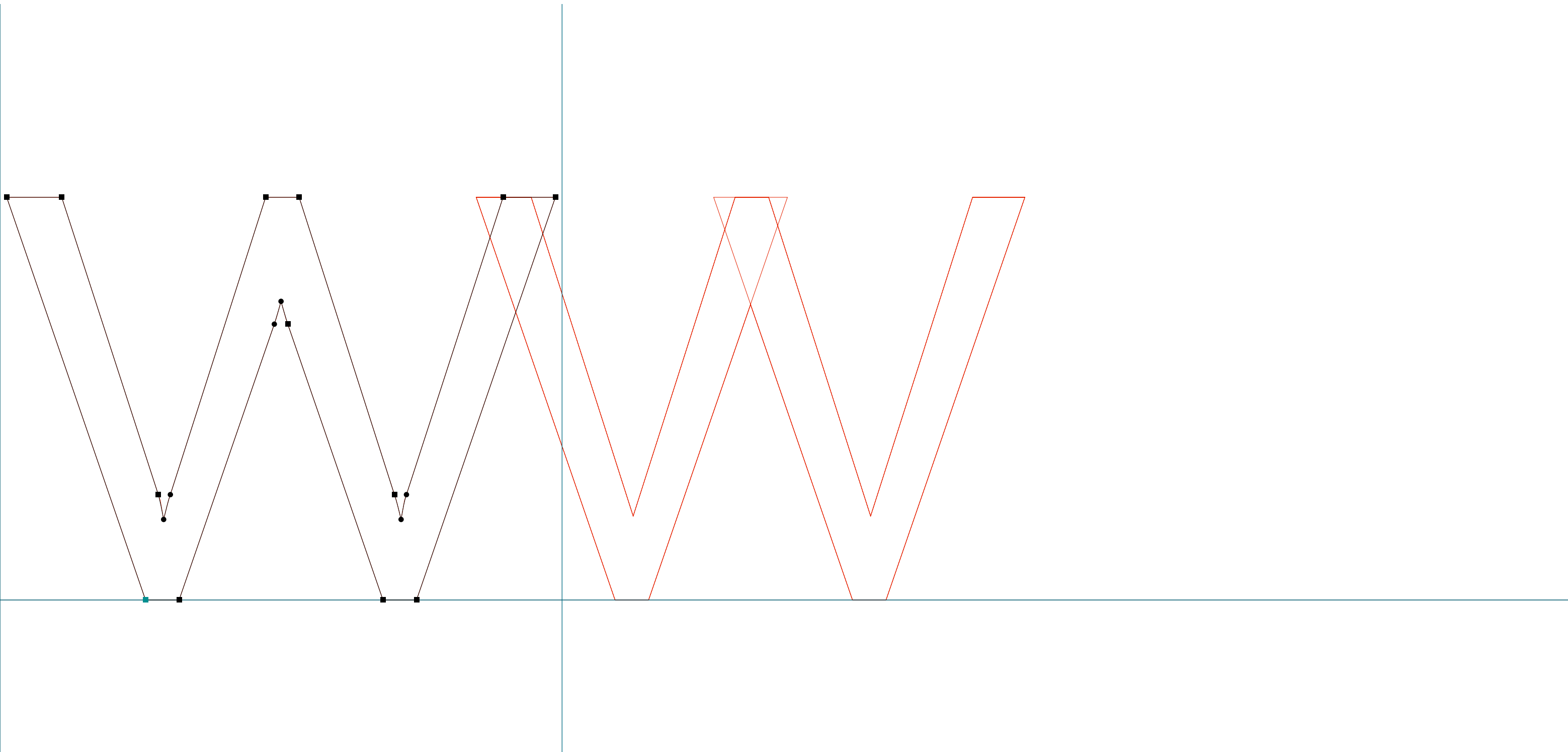

MR EAVES SANS & MODERN

.....
MrsEavesXLSan RSAVE | a | RoboFog Sketches | 2009 | Emigre Fonts

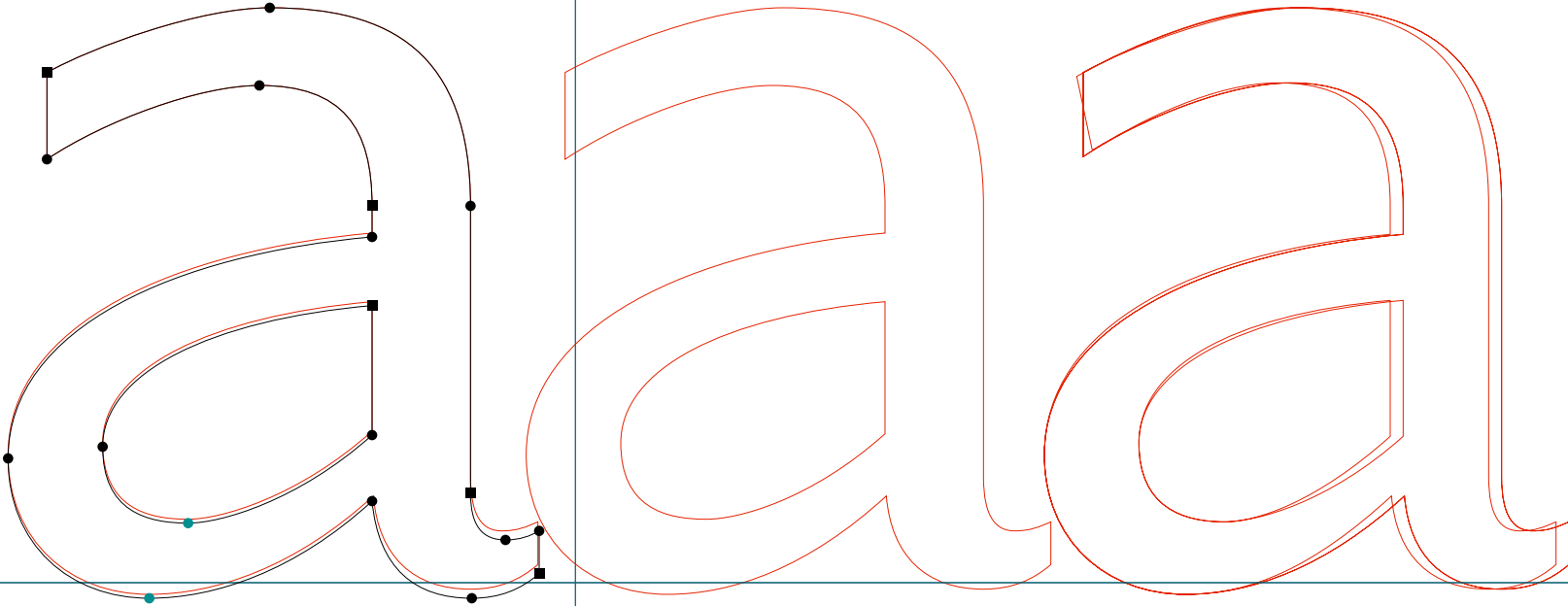

MR EAVES SANS & MODERN

MrsEavesXLSan RSAVE | b | RoboFog Sketches | 2009 | Emigre Fonts

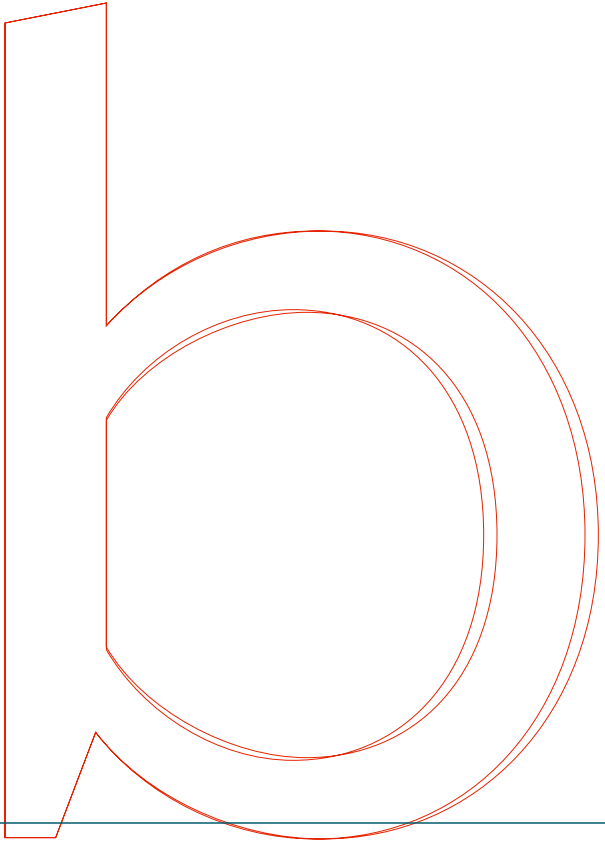
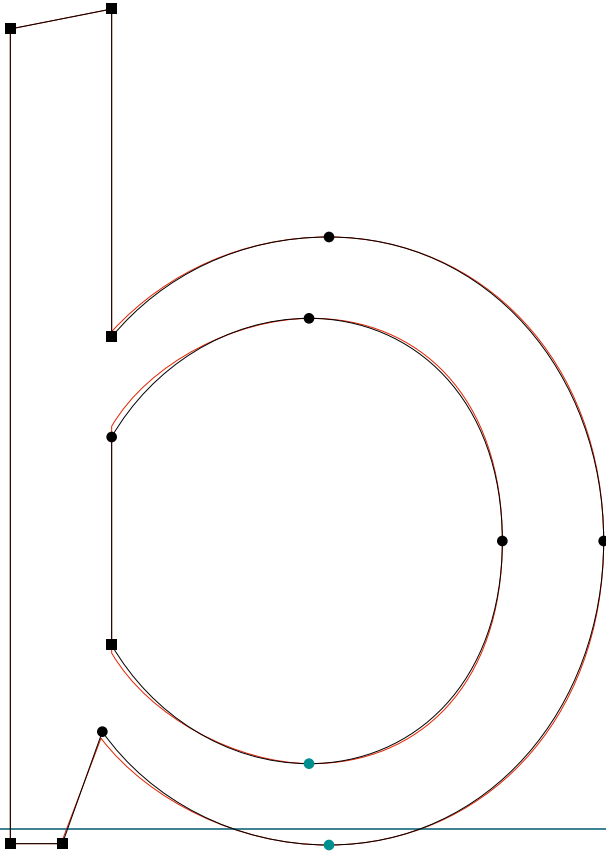

MR EAVES SANS & MODERN

MrsEavesXLSan RSAVE | c | RoboFog Sketches | 2009 | Emigre Fonts



MR EAVES SANS & MODERN

.....
MrsEavesXLSan RSAVE | d | RoboFog Sketches | 2009 | Emigre Fonts

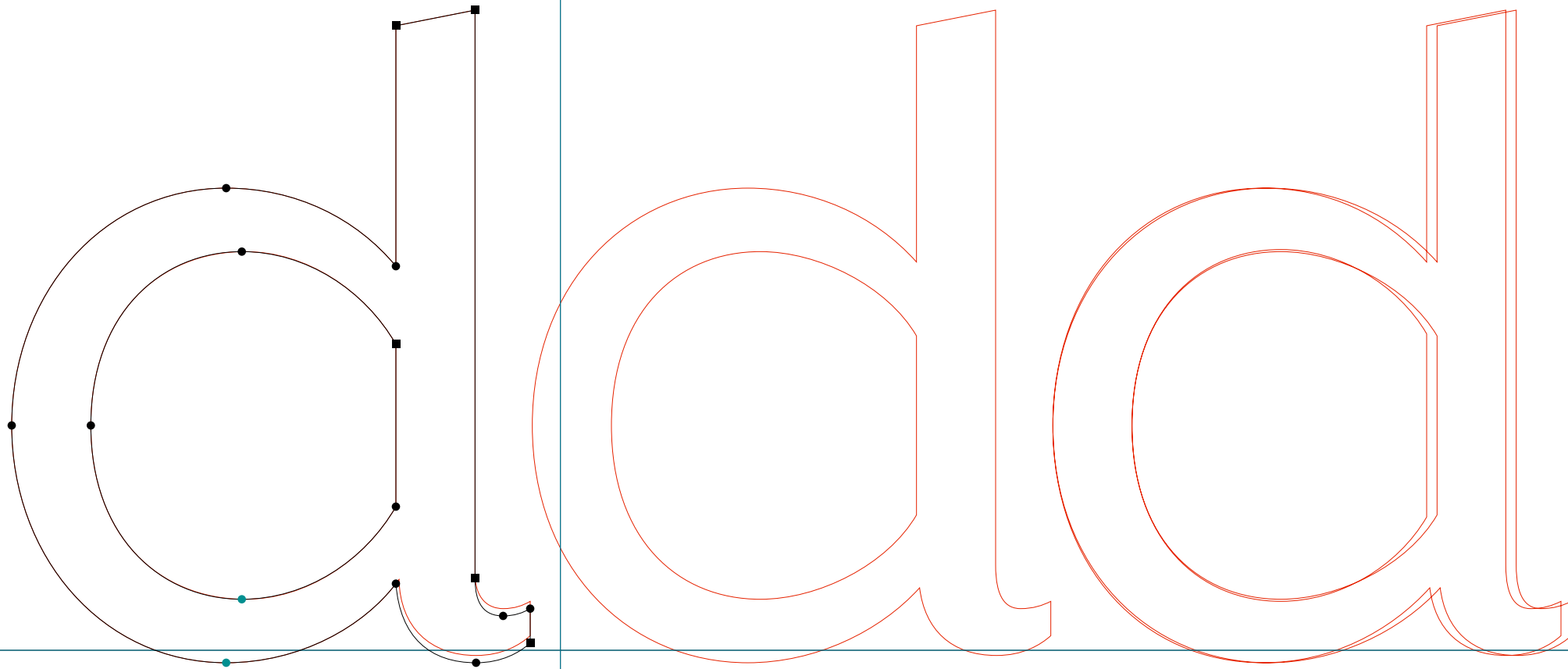

MR EAVES SANS & MODERN

MrsEavesXLSan RSAVE | e | RoboFog Sketches | 2009 | Emigre Fonts

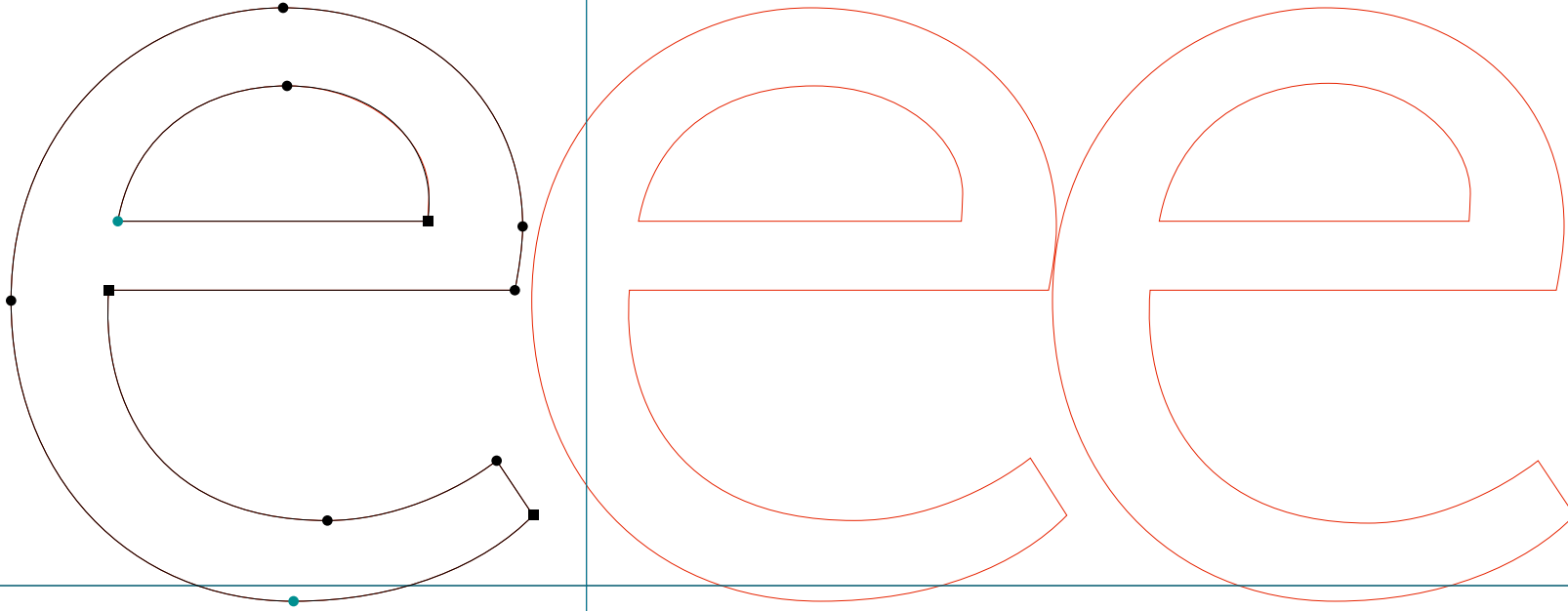

MR EAVES SANS & MODERN

.....
MrsEavesXLSan RSAVE | g | RoboFog Sketches | 2009 | Emigre Fonts

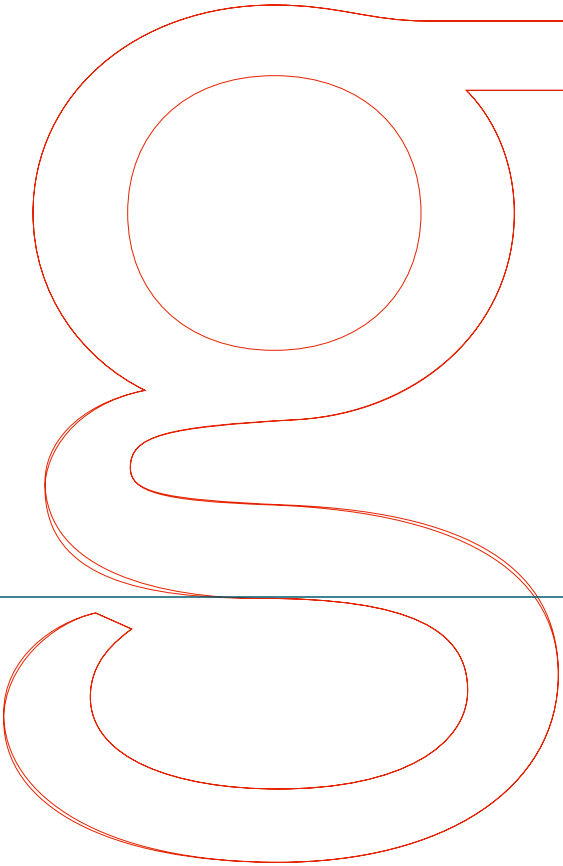
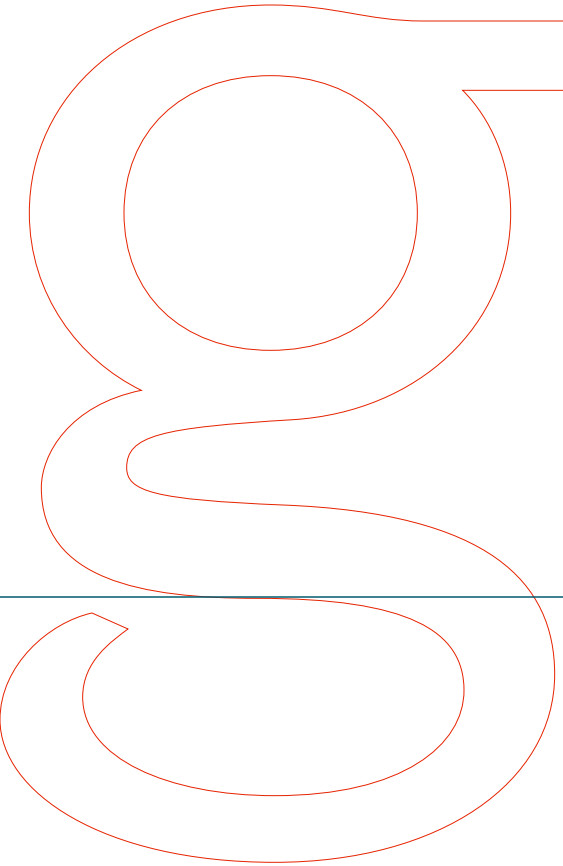
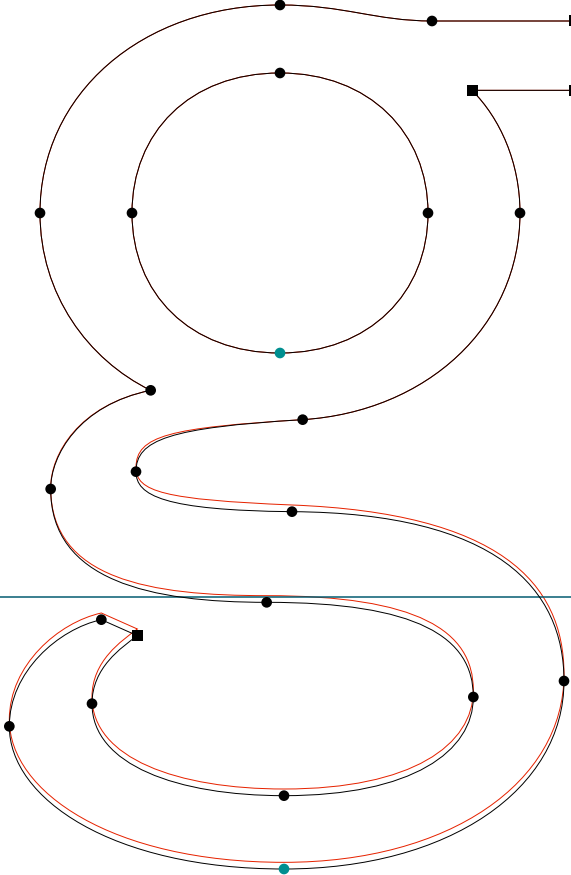
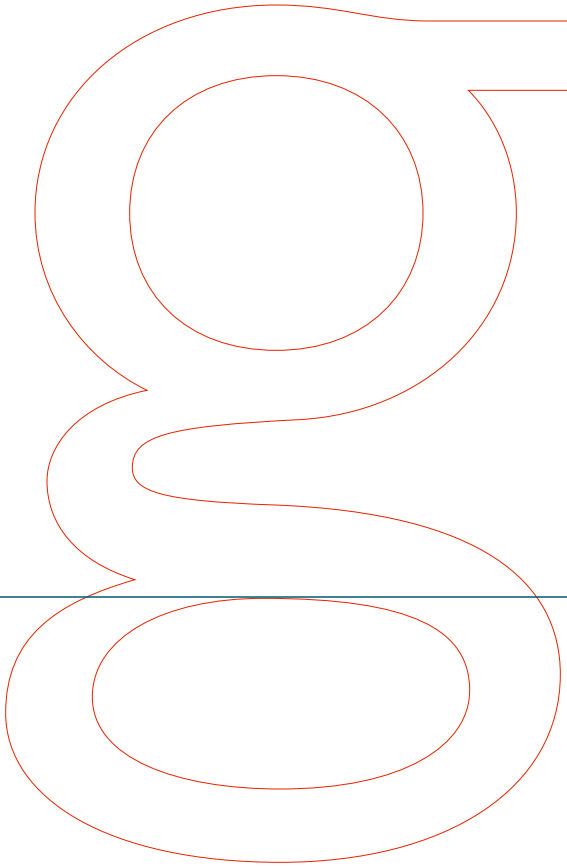

MR EAVES SANS & MODERN

.....
MrsEavesXLSan RSAVE | j | RoboFog Sketches | 2009 | Emigre Fonts

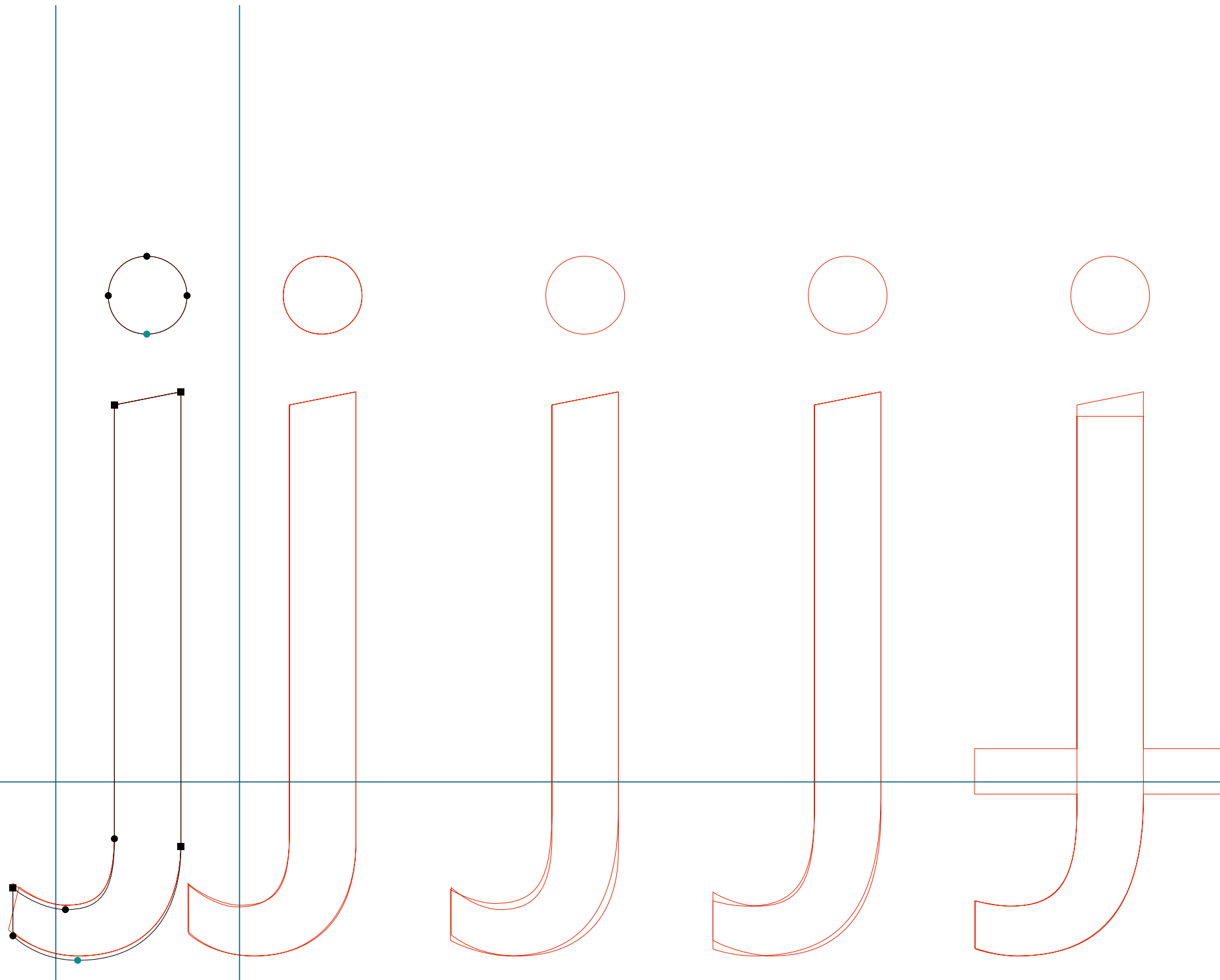

MR EAVES SANS & MODERN

.....
MrsEavesXLSan RSAVE | p | RoboFog Sketches | 2009 | Emigre Fonts

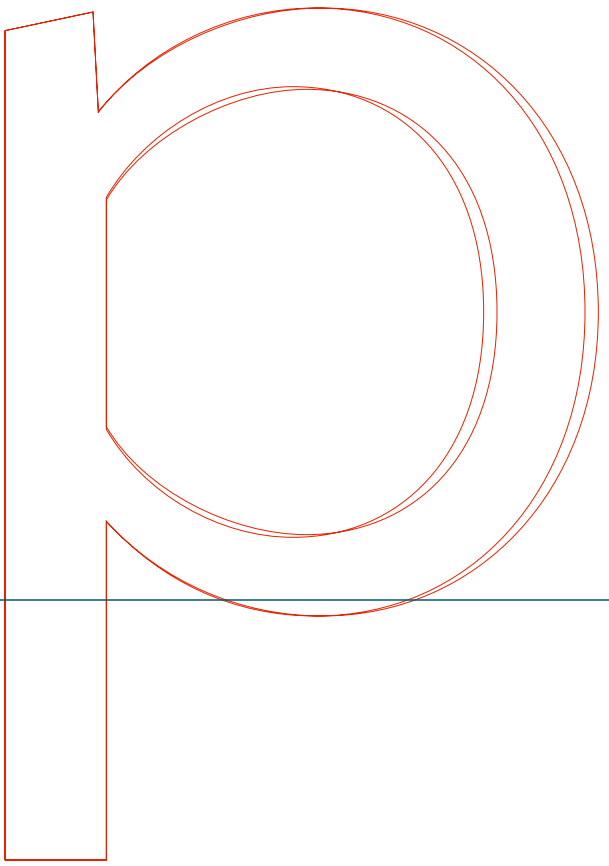
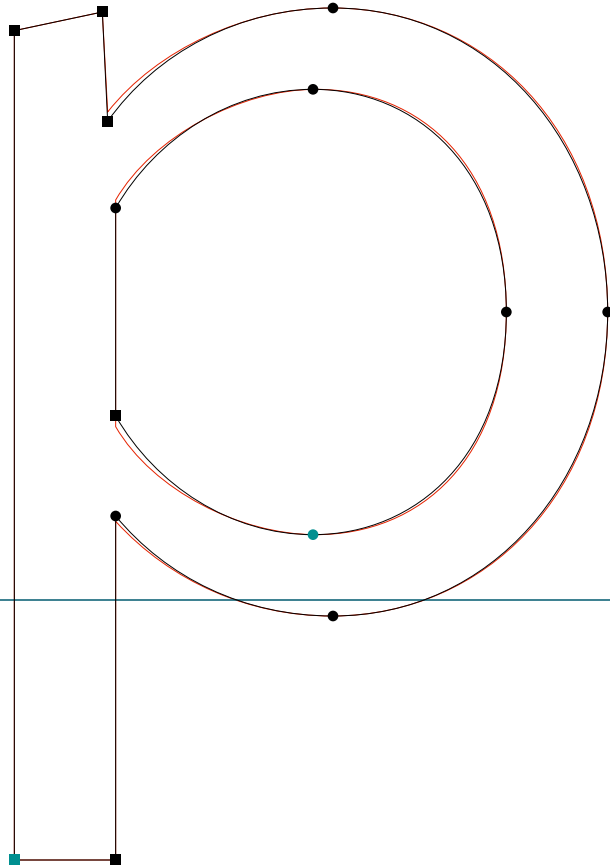

MR EAVES SANS & MODERN

.....
MrsEavesXLSan RSAVE | q | RoboFog Sketches | 2009 | Emigre Fonts

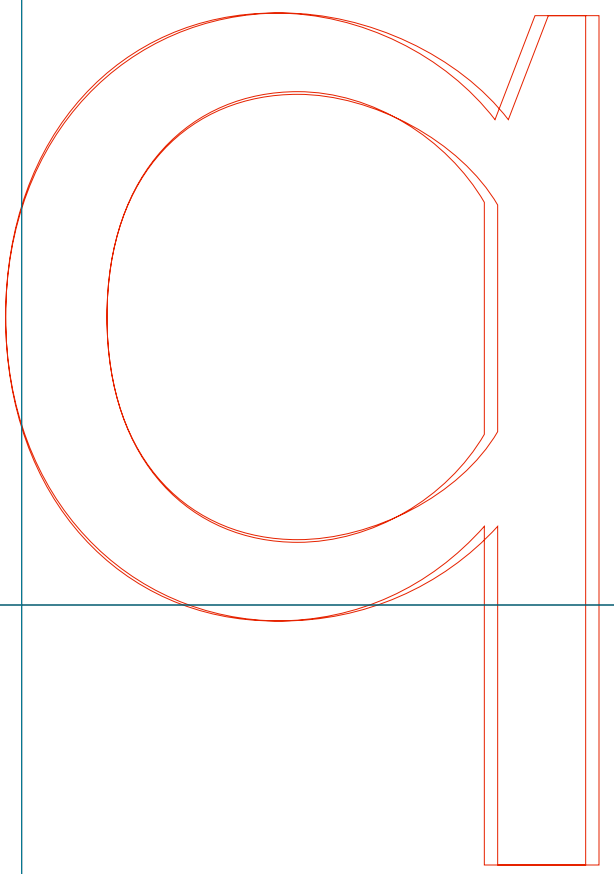
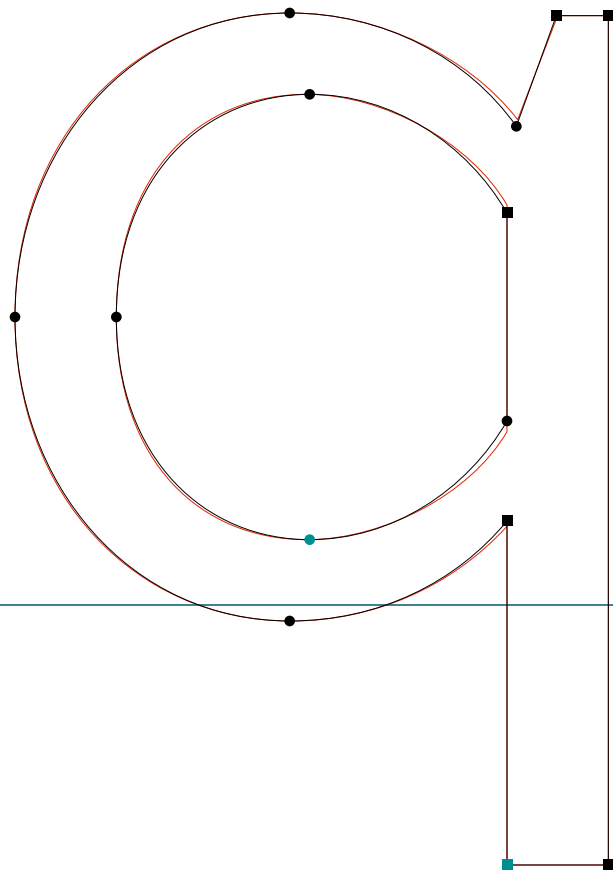

MR EAVES SANS & MODERN

MrsEavesXLSan RSAVE | s | RoboFog Sketches | 2009 | Emigre Fonts

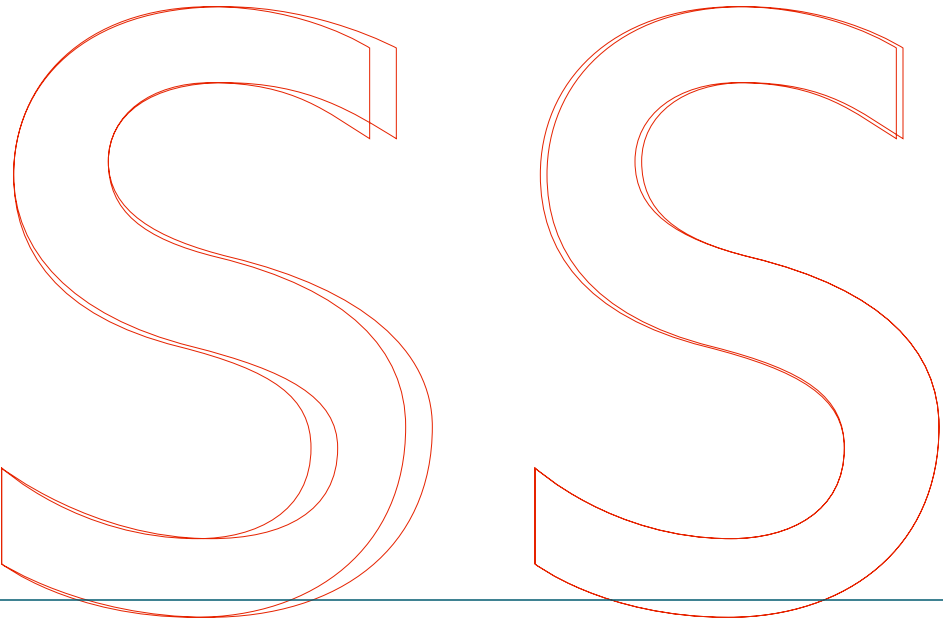
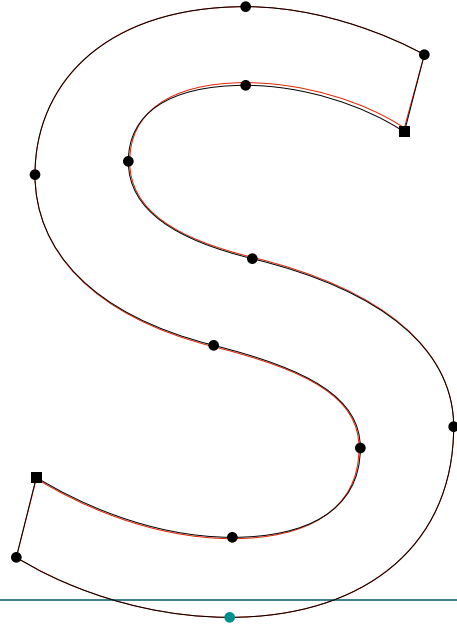

MR EAVES SANS & MODERN

.....
MrsEavesXLSan RSAVE | u | RoboFog Sketches | 2009 | Emigre Fonts

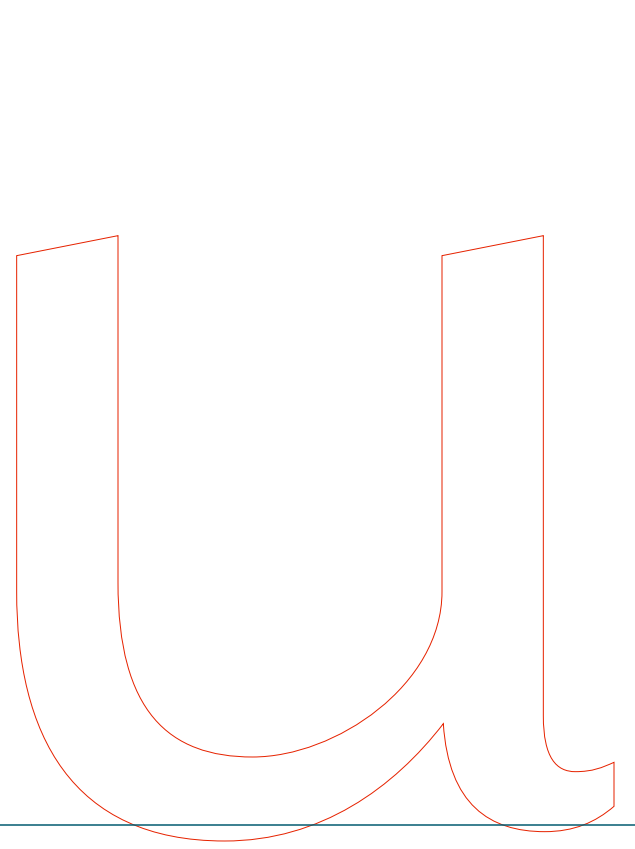
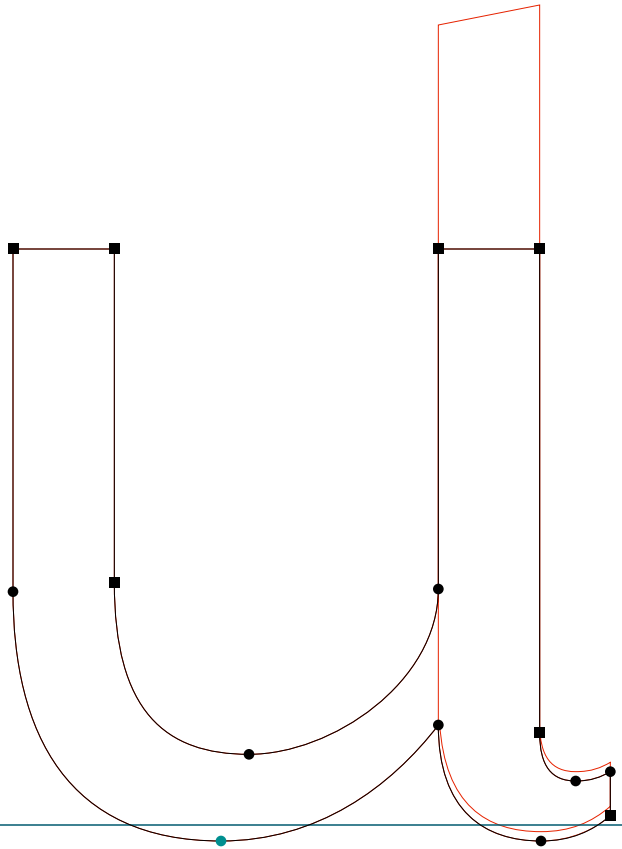

MR EAVES SANS & MODERN

.....
MrsEavesXLSan RSAVE | y | RoboFog Sketches | 2009 | Emigre Fonts

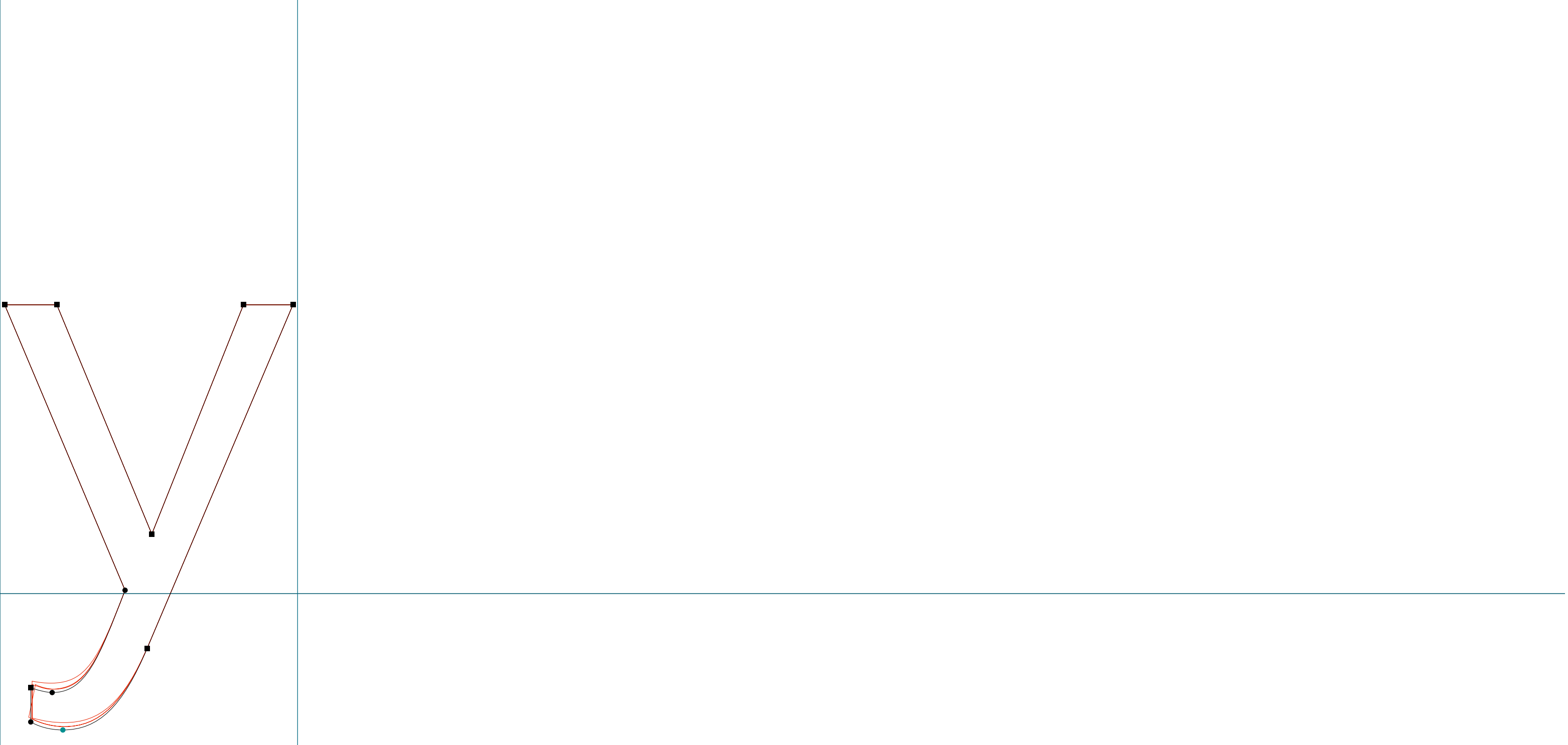

MR EAVES SANS & MODERN

.....
MrsEavesXLSan RSAVE | cent | RoboFog Sketches | 2009 | Emigre Fonts

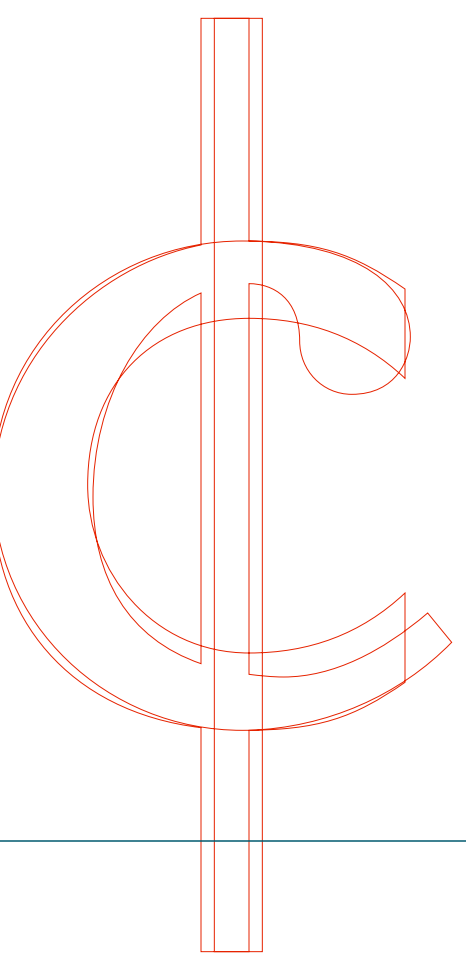
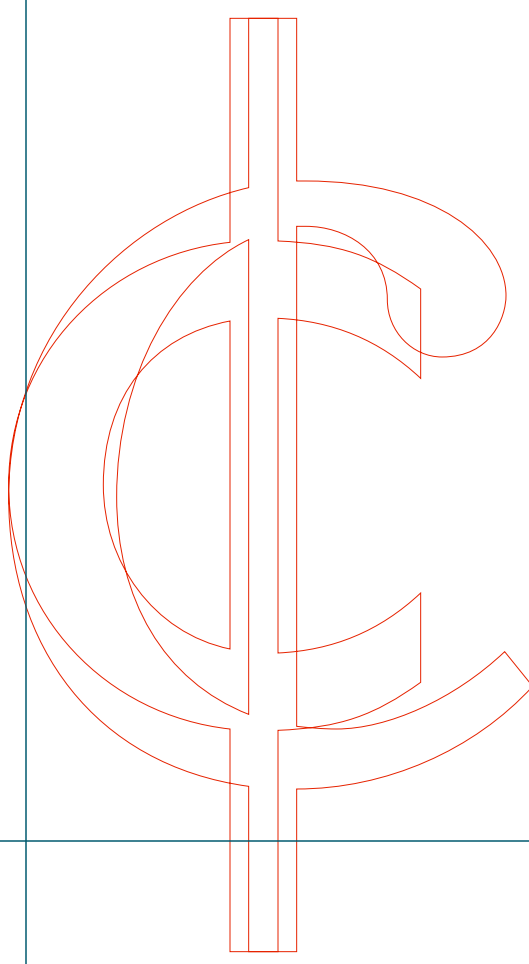
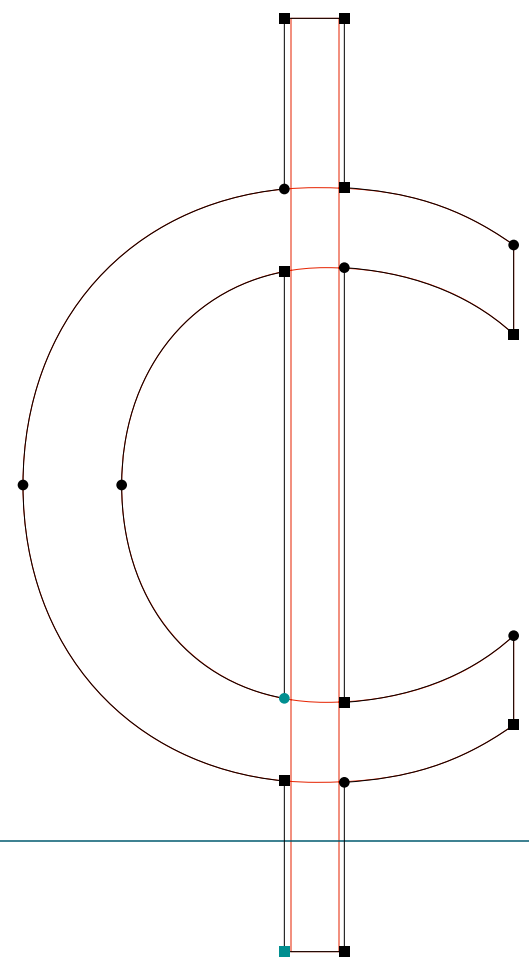

MR EAVES SANS & MODERN

.....
MrsEavesXLSan RSAVE | yen | RoboFog Sketches | 2009 | Emigre Fonts

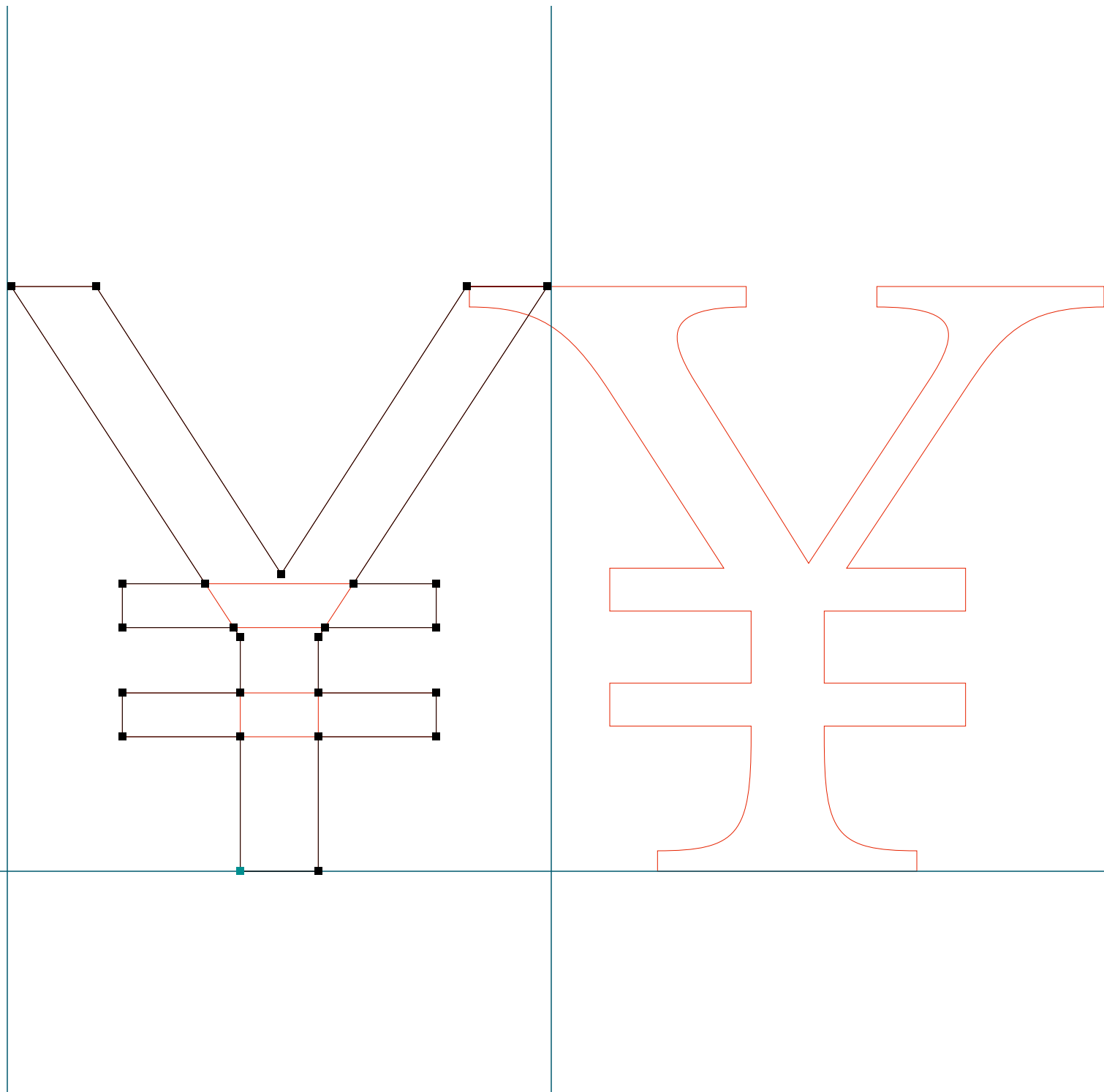

MR EAVES SANS & MODERN

.....
MrsEavesXLSan RSAVE | quotedblright | RoboFog Sketches | 2009 | Emigre Fonts

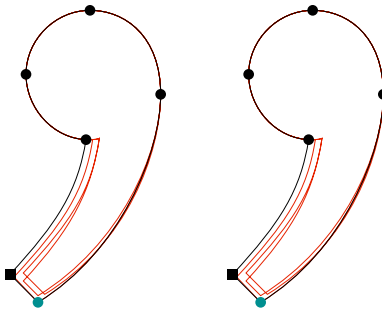

MR EAVES SANS & MODERN

.....
MrsEavesXLSan RSAVE | quoteright | RoboFog Sketches | 2009 | Emigre Fonts

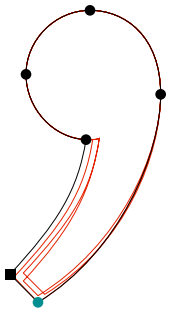

MR EAVES SANS & MODERN

.....
MrsEavesXLSan RSAVE | apple | RoboFog Sketches | 2009 | Emigre Fonts

